

# APM-4MJ

## Din Rail Power Meter

### User Manual

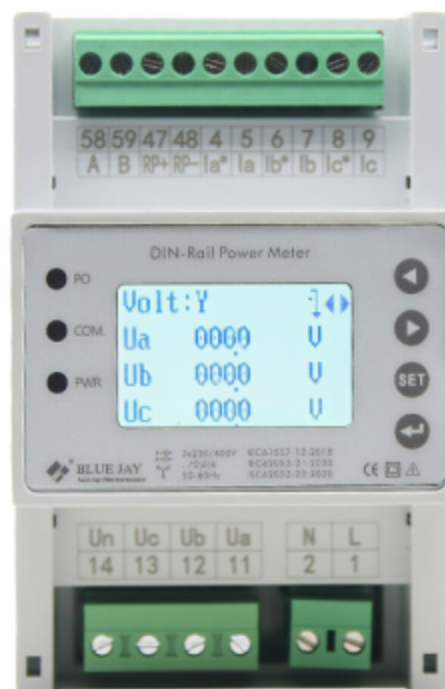

**Version: 1.14**

**Revision: 2026.06**

## Read me

**When you use APM-4MJ multi-function meter, be sure to read this user manual carefully, and be able to fully understand the implications, the correct guidance of operations in accordance with user manual, which will help you make better use of APM-4MJ multi-function meter, and help to solve various problems at the scene.**

1. Before the meter turn on the power supply, be sure that the power supply within the provisions of the instrument;
2. When installation, the current input terminal must be non-open, voltage input terminals must be Non-short circuit;
3. Communication terminal (RS232/RS485) is strictly prohibited to impose on high pressure;
4. Be sure the instrument wiring is consistent with the internal system settings;
5. When communicating with the PC, instrument communication parameters must be consistent with the PC.



- **Please read this user manual carefully**
- **Please save this document**

## Directory

<b>1.- SUMMARIZE .....</b>	<b>- 1 -</b>
<b>2.- FEATURES .....</b>	<b>- 2 -</b>
2.1.- ELECTRICITY METERING.....	- 2 -
<b>3.- INSTALLATION AND START-UP .....</b>	<b>- 5 -</b>
3.1. - INSTALLATION.....	- 5 -
3.2.- CONNECTION TERMINAL .....	- 9 -
3.3.- TYPICAL WIRING.....	- 10 -
<b>4.- OPERATION MODE .....</b>	<b>- 12 -</b>
<b>5.- SCREEN DISPLAY .....</b>	<b>- 13 -</b>
5.1.- OVERALL SCREEN:.....	- 13 -
5.2.- DETAIL PARAMETER SCREEN:.....	- 15 -
5.2.1.- THE DETAIL INFORMATION OF BASIC ELECTRICAL PARAMETERS .....	- 15 -
5.2.2.- THE DETAIL INFORMATION OF THD AND INDIVIDUAL HARMONIC.....	- 16 -
5.2.3.- THE DETAIL INFORMATION OF DEMANDS RECORD .....	- 17 -
5.2.4.- THE DETAIL INFORMATION OF TIME OF USE (MULTI-TARIFF).....	- 18 -
<b>6. - SETUP PROCEDURE .....</b>	<b>- 19 -</b>
6.1. - ENTER SETUP MENU.....	- 19 -
6.2. - THE DETAIL OF METER CONFIGURATION.....	- 20 -
<b>7.- PULSE OUTPUT .....</b>	<b>- 23 -</b>
<b>8. - COMMUNICATION INTERFACE .....</b>	<b>- 24 -</b>
8.1. - CONNECTION FOR RS485 BUS .....	- 24 -
8.2. - MODBUS © PROTOCOL.....	- 25 -
8.3. - REGISTER MAP.....	- 26 -
<b>9.- SAFETY CONSIDERATIONS .....</b>	<b>- 37 -</b>
<b>10.- MAINTENANCE .....</b>	<b>- 37 -</b>
<b>11. - TECHNICAL SERVICE .....</b>	<b>- 38 -</b>

## 1.- SUMMARIZE

APM-4MJ Din rail multi-function power meter has functions such as programmable measurement, display, transmission output, digital communication and power pulse output. It can complete power measurement, power metering, data display, collection and transmission.

The measurement accuracy is 0.2 level, which can be achieved on-site display and remote RS-485/MODBUS-RTU communication and optional Profibus-DP protocol.

### It can measure all power parameters in power grid:

Current,	Apparent power,	Harmonics factor,
Voltage,	Energy (Active/reactive),	Voltage crest factor,
Frequency,	Power factor,	Current K-factor,
Active power,	Current harmonics 2~63 times,	Multi- tariffs ratio,
Reactive power,	Voltage harmonics 2~63 times,	Demand record,
Voltage /current unbalance,	Voltage and current THD%,	Voltage/frequency deviation,
50 lists SOE record,	Phase energy measurement,	

### APPLICATIONS

- Measure all power parameters;
- Renewable energy systems;
- Medium and low voltage systems;
- SCADA, EMS, DCS integrators;
- Remote meter reading, load management and demand response for smart grids;
- Transformers, generators, capacitors and electric motors distributed detection.

## 2.- FEATURES

### 2.1.- Electricity Metering

By means of an internal microprocessor it simultaneously measures:

Parameter	Symbol	A-phase	B-phase	C-phase	Total
Phase-line voltage	V	•	•	•	/
Phase-phase voltage	V	•	•	•	/
Current	A	•	•	•	/
Frequency	Hz	/	/	/	•
Power factor	Cos $\Phi$	•	•	•	•
Active power	W	•	•	•	•
Reactive power	Var	•	•	•	•
Apparent power	VA	•	•	•	•
Active energy	Wh	•	•	•	•
Reactive energy	Varh	•	•	•	•
Multi-tariffs energy record	Wh	/	/	/	•
Max demand (W / var / VA)	MAX	/	/	/	•
Voltage / frequency deviation	V	•	•	•	/
Voltage / current unbalance	%	/	/	/	•
THD & Harmonic (2~63 <sup>rd</sup> )	THD	•	•	•	•

•: Display and communications

o: Optional functions

/: No such function

#### Note:

Phase-phase voltage is Uab, Ubc, Uca, voltage data determined by the different wiring.

APM-4MJ delivers the visualization of parameters listed above by means of LCD type displays. In the main display area show 3 power parameters, with other display area show the various parameters and state of meter on each page jump. For more details of measurement parameters please refer to the subsequent for displays introduction and RS485 communication instructions.

#### OTHER FEATURES

- Din-rail mounting meter;
- True R.M.S. measuring system;
- Instantaneous, maximum and minimum values of each measured parameter;
- Energy measurement (indication through a lighting led);
- RS-485 communication to a PC.

## 2.2.- Technical parameters

### - Working Power

AC/DC 85-265V, (DC 48V or AC 380V customized)  
45-65Hz  
Consumption  $\leq 4VA$

### - Reference Standard

Basic electricity	IEC 61557-12:2018
Active energy	IEC 62053-22:2020
Reactive energy	IEC 62053-24:2020

### - Input

Voltage	AC 100V, 220V, 380V optional (please specify when ordering)
Current	AC 1A, 5A, 100mA optional (please specify when ordering)
Frequency	40~65Hz
Current overload	Measurement: 1.2 times Instantaneous: 10 times/1s
Voltage overload	Measurement: 1.2 times Instantaneous: 2 times/10s

### - Output

Communication	RS485, MODBUS-RTU
Selectable output	1* Pulse output / 1* Digital output (only choose one)

### - Load

Voltage:  $< 0.1VA$  / phase (rated 220V)  
Current:  $< 0.4VA$  / phase (rated 5A)

### - Safety

4kV AC RMS 1 minute, between input / output / case / power supply  
Input, output and power supply to the chassis  $\geq 100M\Omega$

**- Accuracy**

Parameter	Accuracy	A phase	B phase	C phase	All
Voltage	0.2	V1	V2	V3	
Current	0.2	A1	A2	A3	
Active power	0.5s	W1	W2	W3	W
Reactive power	0.5s	var1	var2	var3	var
Apparent power	0.5s	VA1	VA2	VA3	VA
Power factor	0.5s	PF1	PF2	PF3	PF
Active energy	0.5s				Wh
Reactive energy	1.0				varh
Frequency	0.02				Hz

**Others**

Deviation	Voltage: 0.2%; Frequency: 0.02%
Unbalance	Voltage: 0.2%; Current: 0.2%
Harmonic content	When $U_h > 2\%$ : $5\%U_h$ ; when $U_h \leq 2\%$ : $0.1\%U_N$
Demand record	Maximum monthly demand in the past three months
Multi- tariffs ratio	4 sets rates, 12 segments

**- Environment**

Working temperature:  $-10^{\circ}\text{C} \sim +55^{\circ}\text{C}$ ; RH 20% ~ 95% (Non-condensation)

Storage temperature:  $-30^{\circ}\text{C} \sim +70^{\circ}\text{C}$ ; RH 20% ~ 95% (Non-condensation)

### 3.- INSTALLATION AND START-UP



The manual you hold contains information and warnings that -users should follow in order to guarantee a proper operation of all the instrument functions and keep it in safety conditions. The instrument must not be powered on and used until its definitive assembly is on the cabinet's door.

**If the instrument is not used as manufacturer's specifications, the protection of the instrument will be damaged.**

When any protection failure is suspected to exist (for example, it presents external visible damages), the instrument must be immediately powered off. In this case contact a qualified service representative.

#### 3.1. - Installation

##### Mounting

The instrument is to be mounted on the 35mm Din-rail. Keep all connections inside the cabinet.

Note that with the instrument powered on, the terminals could be dangerous to touch. and cover opening actions or elements removal may allow accessing dangerous parts. Therefore, the instrument must not be used until this is completely installed.

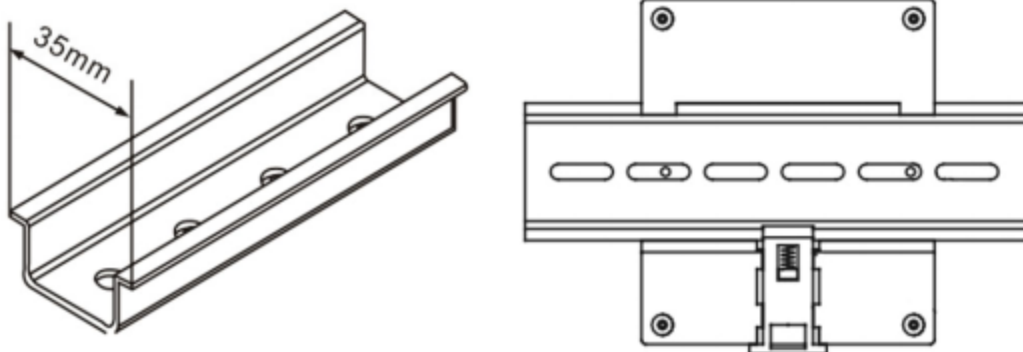

**Dimension**

W\*H\*D: 72\*110\*66 mm

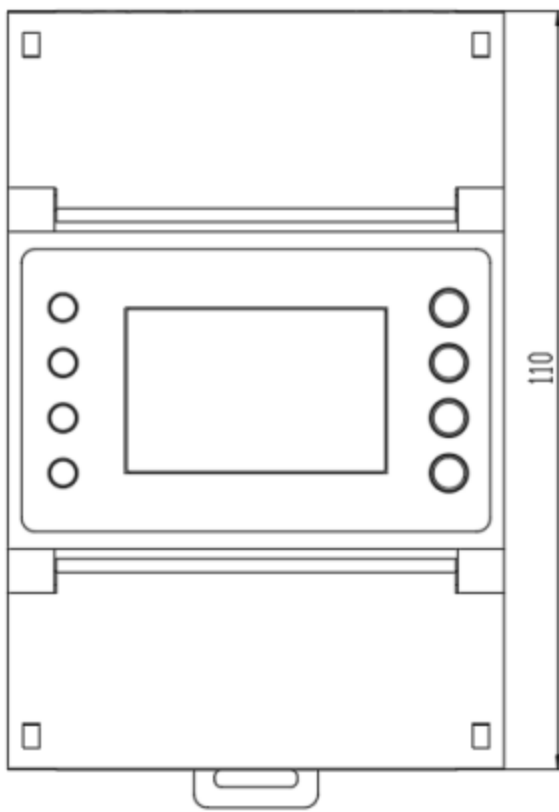

**Front view**

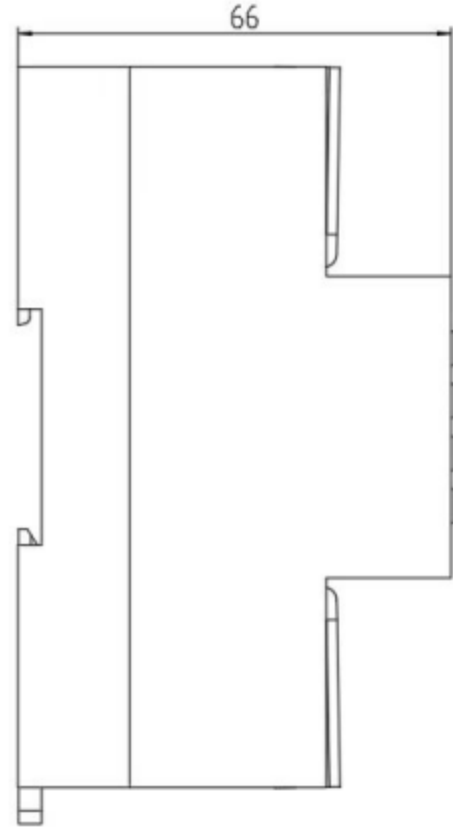

**Side view**

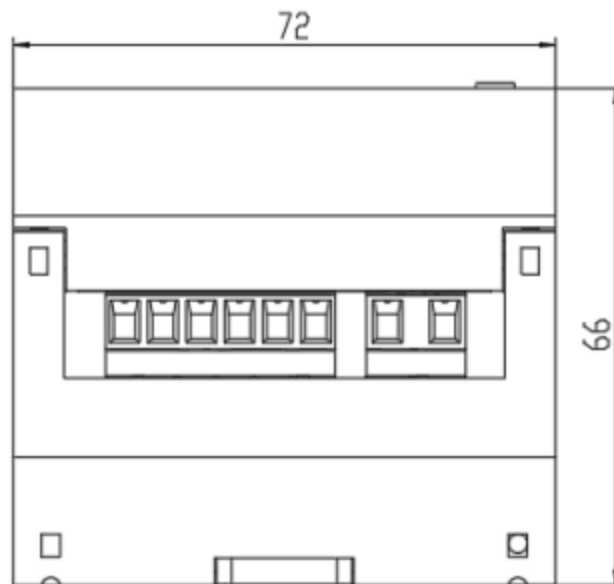

**Upper view**

**Notes:**

Input signal: APM-4MJ using a separate acquisition calculate for each measurement channel, to ensure consistent in use, for different load forms, it's a variety of connection mode. Access wire shall be met 2.5 square mm.

**A. Voltage input**

Input voltage should not exceed the rated input voltage products 450V.  
Otherwise, you should use external VT. Suggest 1A fuse be installed in the voltage input side.

**B. Current Input**

Standard input current is 5A or 1A, if greater than 5A/1A should use external CT.  
When the CT is connected with other meters, make sure wiring methods be used in series.

**Warning: Forbid to install a CT on the live feeder wire with open secondary leads. This can be extremely dangerous!**

Before remove the current input connection, must be sure to disconnect the primary circuit or shorted secondary circuit of CT.

**C. Sequence of wire**

**Warning: Please make sure that the input voltage and current corresponding to the same phase, sequence, and the same direction; Otherwise, the Values and symbols will be wrong! (Power and Energy)**

Always observe the physical orientation of CT (P1 - P2) when installing on the feeder wire.  
Always pay attention to wiring polarity and phasing when terminating the CT leads to the APM-4MJ.  
S1 connect to Ix\*, S2 connect to Ix.

The input network configuration of instrument depends on the CT number of the system:  
in the condition of 2 CT, select the three-phase, three-lines two components;  
in the condition of 3 CT, select the three-phase, four-lines three component mode.

Instrument connection mode, set of the instrument (programming input network NET) should be the same load wiring as measured wiring. Otherwise, the measurement instrument will lead to incorrect voltage or power.

In three-phase 3 wire mode, measurement and shows the line voltage;  
In three-phase 4 wire mode, measurement and shows the phase voltage and line voltage both.

#### **D. Auxiliary power**

APM-4MJ with universal (AC / DC) power input, if not for a special statement, we provide the 90-240AC/DC power interface for standard products, please ensure that the auxiliary power can match with meter to prevent unexpected damage.

- A. Suggest install 1A fuse in the fire line side.
- B. For the areas with poor power quality, suggest install lightning surge suppressor and rapid burst suppressor to prevent lightning strikes.

### 3.2.- Connection Terminal

#### Upper terminal

No.	Marked	Notes
58	RS485	RS485+
59		RS485-
47	RP+	Active energy pulse output +
48	RP-	Active energy pulse output -
4	la*	Current A-phase - S1 input
5	la	Current A-phase - S2 input
6	lb*	Current B-phase - S1 input
7	lb	Current B-phase - S2 input
8	lc*	Current C-phase - S1 input
9	lc	Current C-phase - S2 input

#### Lower terminal

No.	Marked	Notes
14	Un	Neutral voltage input
13	Uc	Voltage C phase input
12	Ub	Voltage B phase input
11	Ua	Voltage A phase input
1	L	AUX input 85-265Vac/dc
2	N	Connect extra 1A, 250V fuse @ L line

#### Note:

**The terminal pin definition may change depends on customer order; please refer to the label on the meter!**

### 3.3.- Typical Wiring

- 1P2W/ 2P3W wiring method

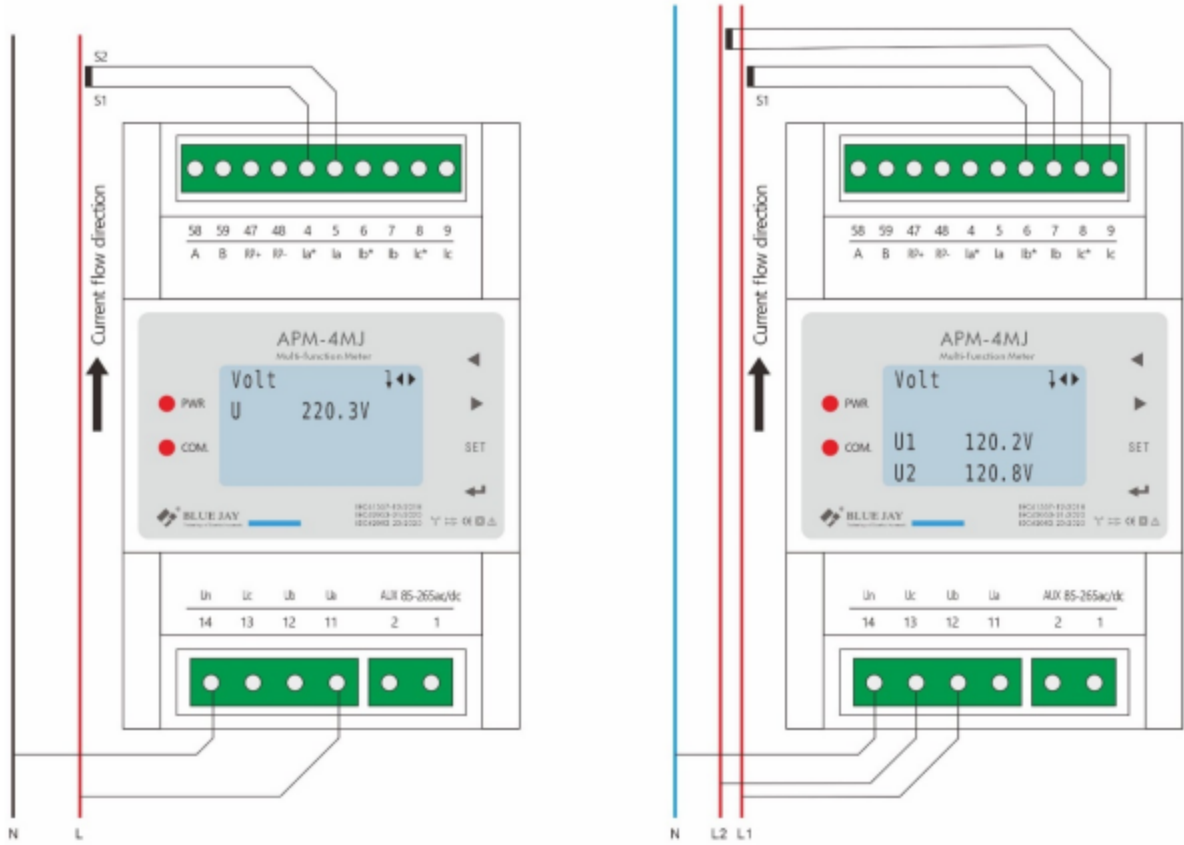

● 3P4W/ 3P3W wiring method

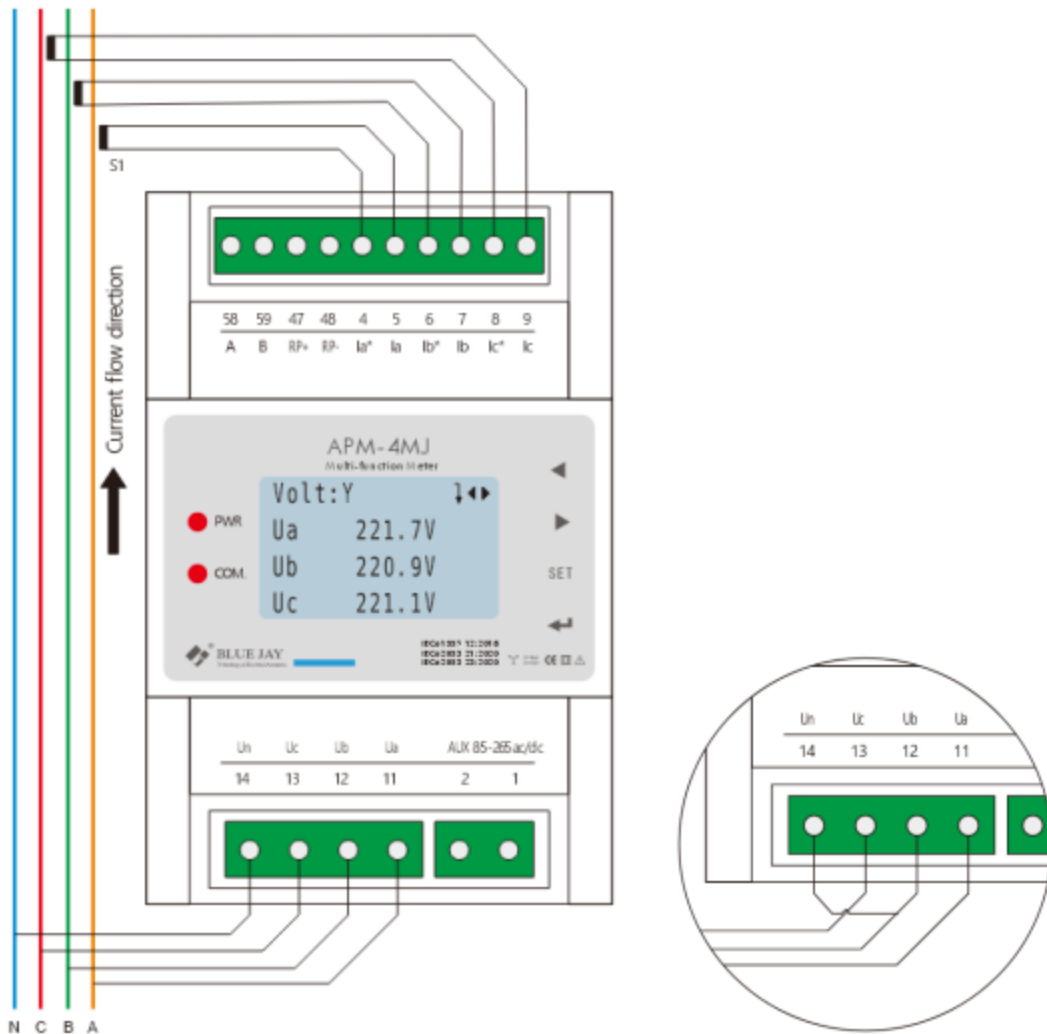

**Notes:**

This connection drawing is for reference only; the actual connecting terminal, please refer to the label on the rear part.





**WARNINGS!**

If power = -0.01 is shown for any of the phases and voltage and current are not zero for this phase, check out following points:

- Assure that A, B and C phases coincide in voltage and current.
- Correct polarity? Reverse the current transformer placed at this phase.

## 4.- OPERATION MODE

When the device is powered on, the entire symbol will be on, and the meter starts to self- test. After few seconds, the meter is ready for operation and shows firmware, then automatic jump to The first screen.

Button	In Monitor Screen	In Config Sub-menu	In Parameter Setup
	Screen will move to previous or next page	Move cursor up and down to select function	Move setting cursor to left
			Scroll selection number 0 ~ 9
	Call out password screen	Exit & roll back to up level menu.	
	Call out Sub-screen	Confirm the values & Entry or jump to down level menu	

**Note:** In Setup menu, if change the setting value, press  for exit menu, device will call out confirm screen ask "SAVE".

Then press  *exit without saving.*

press  *save and exit.*

## 5.- SCREEN DISPLAY

### 5.1.- Overall screen:

Press the **▶** on any display interface, the corresponding data will be displayed in the measurement data display area.

Each time you press the **▶** it will flip one screen. When you reach the last screen, press the right button to return to the first screen. As shown below:

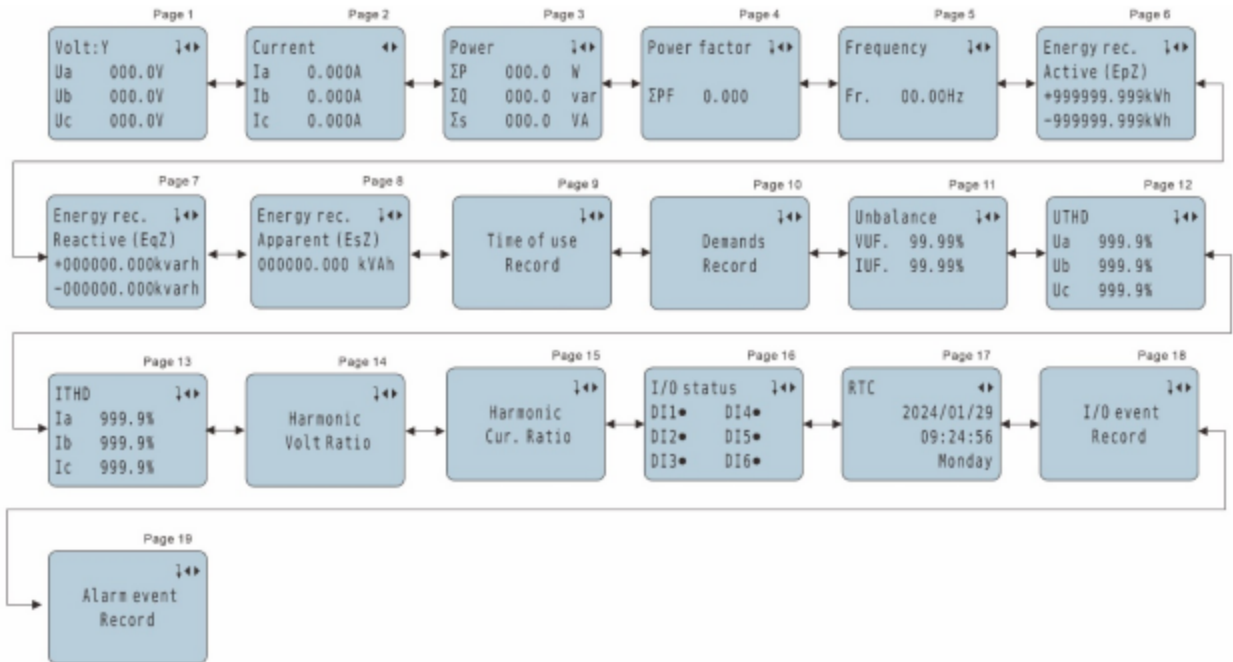

**Note:** Pages marked with **⌵** indicate that this page has a sub-menu.

### 5.1.1. - Screen detailed instructions

Page No.	Description	Page No.	Description
Page 1	System voltage	Page 11	Current and voltage unbalance
Page 2	Primary current	Page 12	Voltage total harmonic distortion
Page 3	Active/ Reactive/ Apparent Power	Page 13	Current total harmonic distortion
Page 4	Power factor	Page 14	Voltage harmonic ratio
Page 5	System frequency	Page 15	Current harmonic ratio
Page 6	Active energy record (Total)	Page 16	DI/DO status
Page 7	Reactive energy record (Total)	Page 17	Real time clock
Page 8	Apparent energy record (Total)	Page 18	DI/DO event record
Page 9	Time of use (multi-tariff) record	Page 19	Alarm event record
Page 10	Demands record	/	

**Note:** All the pictures display all function information. If this meter does not have a certain function, it can be ignored.

## 5.2.- Detail parameter screen:

### 5.2.1.- The detail information of basic electrical parameters

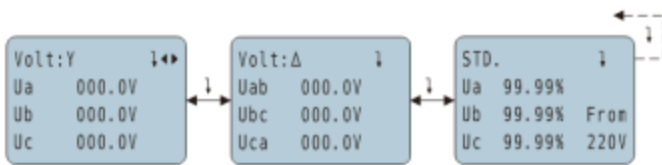

#### System voltage

Phase to line voltage  
Phase to phase voltage  
Voltage standard deviation

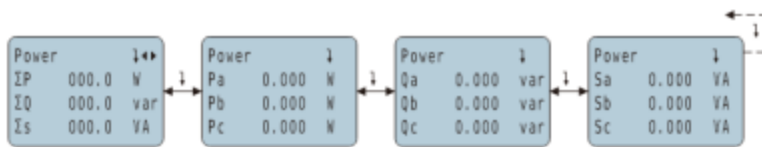

#### Power record

Total and A B C split-phase active, reactive, apparent power



#### Energy record

Total and A B C split-phase active, reactive, apparent energy

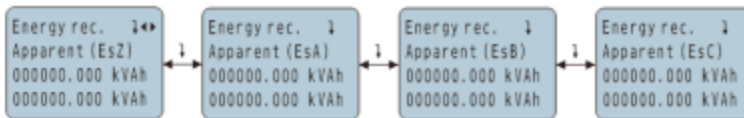
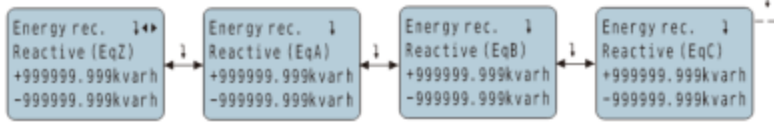

#### Voltage & current unbalance

##### Voltage/ current unbalance

Positive/ negative/ zero sequence voltage in primary side

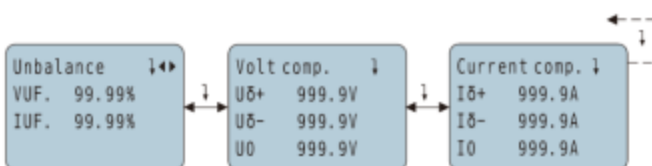

Positive/ negative/ zero sequence current in primary side

**5.2.2.- The detail information of THD and individual harmonic**

<b>UTHD</b> ↓↔ Ua 999.9% Ub 999.9% Uc 999.9%	↔	<b>UTOHD</b> ↓ Ua 999.9% Ub 999.9% Uc 999.9%	↔	<b>UTEHD</b> ↓ Ua 999.9% Ub 999.9% Uc 999.9%
---	---	---	---	---

**Voltage total harmonic distortion**

- Total odd harmonic distortion
- Total even harmonic distortion
- Telephone harmonic
- Crest factor

<b>UTHFF</b> ↓ Ua 999.99% Ub 999.99% Uc 999.99%	↔	<b>UCF</b> ↓ Ua 0.999 Ub 0.999 Uc 0.999
--	---	--

<b>ITHD</b> ↓↔ Ia 999.9% Ib 999.9% Ic 999.9%	↔	<b>ITOHD</b> ↓ Ia 999.9% Ib 999.9% Ic 999.9%	↔	<b>ITEHD</b> ↓ Ia 999.9% Ib 999.9% Ic 999.9%
---	---	---	---	---

**Current total harmonic distortion**

- Total odd harmonic distortion
- Total even harmonic distortion
- Telephone harmonic
- K factor

<b>IKF</b> ↓ Ia 0.999 Ib 0.999 Ic 0.999
--

<b>Harmonic Volt Ratio</b> ↓↔	↔	(%)Ua Ub Uc ↓ 02 999 999 999 03 999 999 999 04 999 999 999	↔	(%)Ua Ub Uc ↓ 62 999 999 999 63 999 999 999
-------------------------------	---	---	---	---

**Harmonic voltage ratio: 2-63<sup>rd</sup>**

**Harmonic current ratio: 2-63<sup>rd</sup>**

<b>Harmonic Cur. Ratio</b> ↓↔	↔	(%)Ia Ib Ic ↓ 02 999 999 999 03 999 999 999 04 999 999 999	↔	(%)Ia Ib Ic ↓ 62 999 999 999 63 999 999 999
-------------------------------	---	---	---	---

**5.2.3.- The detail information of demands record**

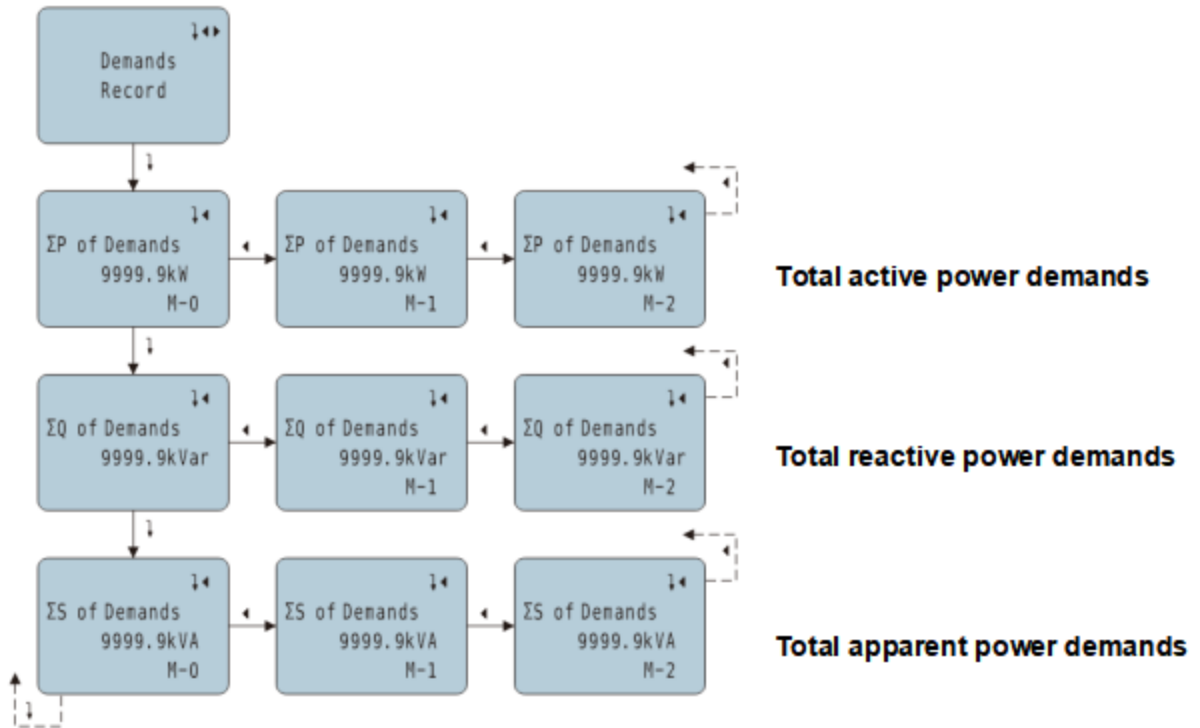

**Note:** To further clarify, take an example:

Assuming this month is March 2025,

**M0 means present month:** refers to March 2025.

**M1 means last month:** refers to February 2025.

**M2 means the month before last month:** refers to data from January 2025.

**5.2.4.- The detail information of time of use (Multi-tariff)**

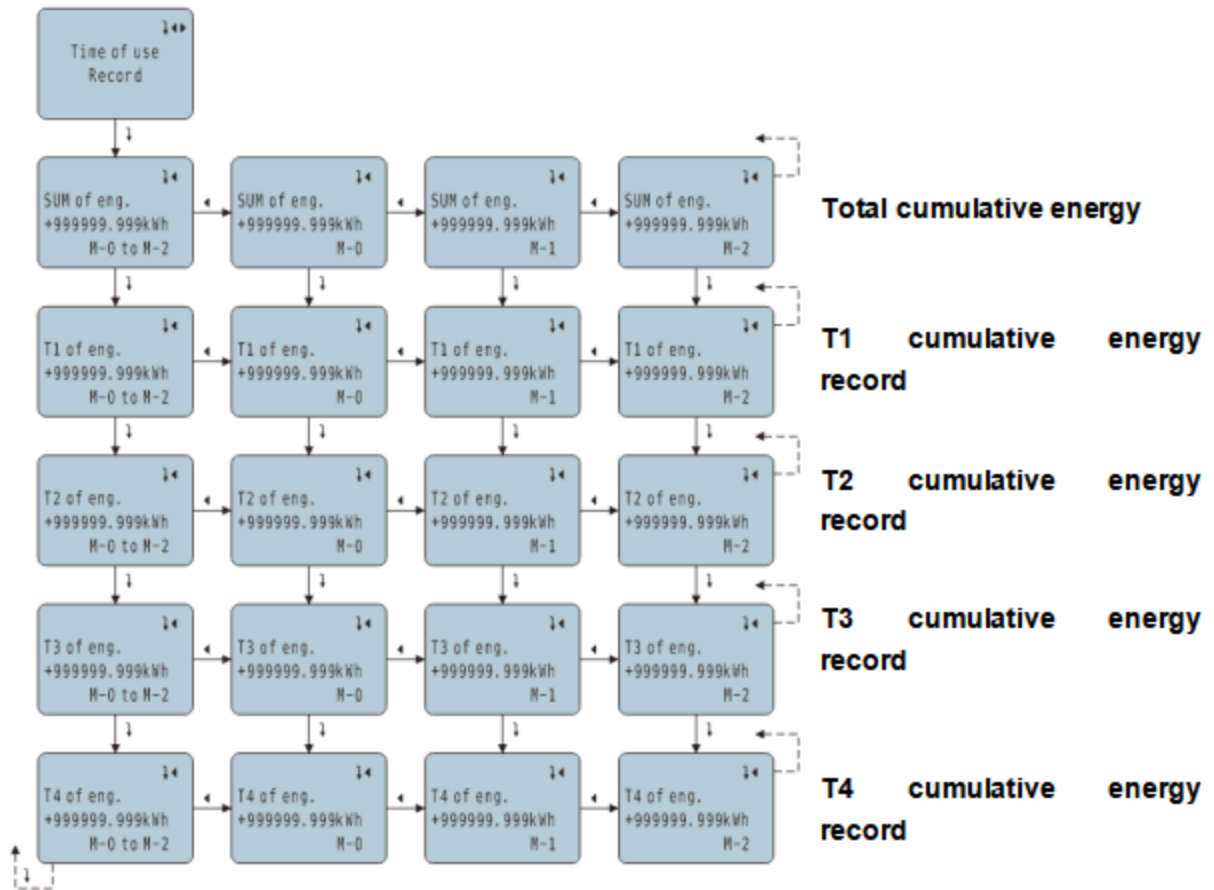

**Note:**

**Sum:** M0+M1+M2 total cumulative energy

**T1:** TOU mode-1

**M0:** Present month

**T2:** TOU mode-2

**M1:** Last month

**T3:** TOU mode-3

**M2:** Month before last month

**T4:** TOU mode-4

## 6. - SETUP PROCEDURE

The SETUP procedure of the APM-4MJ is performed by means of several SETUP options. There is a password to protect unexpectedly to enter the setup menu. Once into the setup menu, use the keyboard to select different options and enter required variables:

### 6.1. - Enter setup menu

Press **SET** button in any of the monitor screen can call out the password page. Enter the default password **0001** can enter the configuration menu.

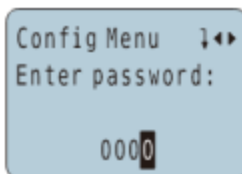

There are 10 sub-menus for meter configuration:

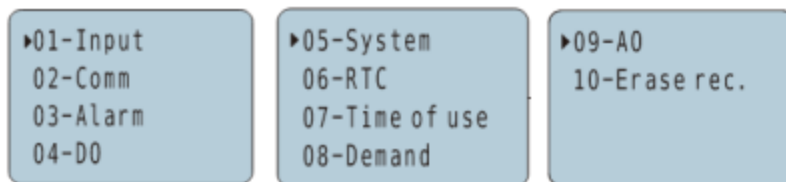

<b>Input</b>	Basic settings of signal access	<b>RTC</b>	Real-time clock setting
<b>Comm</b>	Communication port setting	<b>TOU</b>	Time of use record setting
<b>Alarm</b>	Alarm trig threshold setting	<b>Demand</b>	Demands record setting
<b>DO</b>	Digital relay output port setting	<b>AO</b>	Analog output port setting
<b>System</b>	System settings	<b>Erase rec.</b>	Erase record setting

#### Note:

If the meter does not have the certain function, it can be ignored.

## 6.2. - The detail of meter configuration

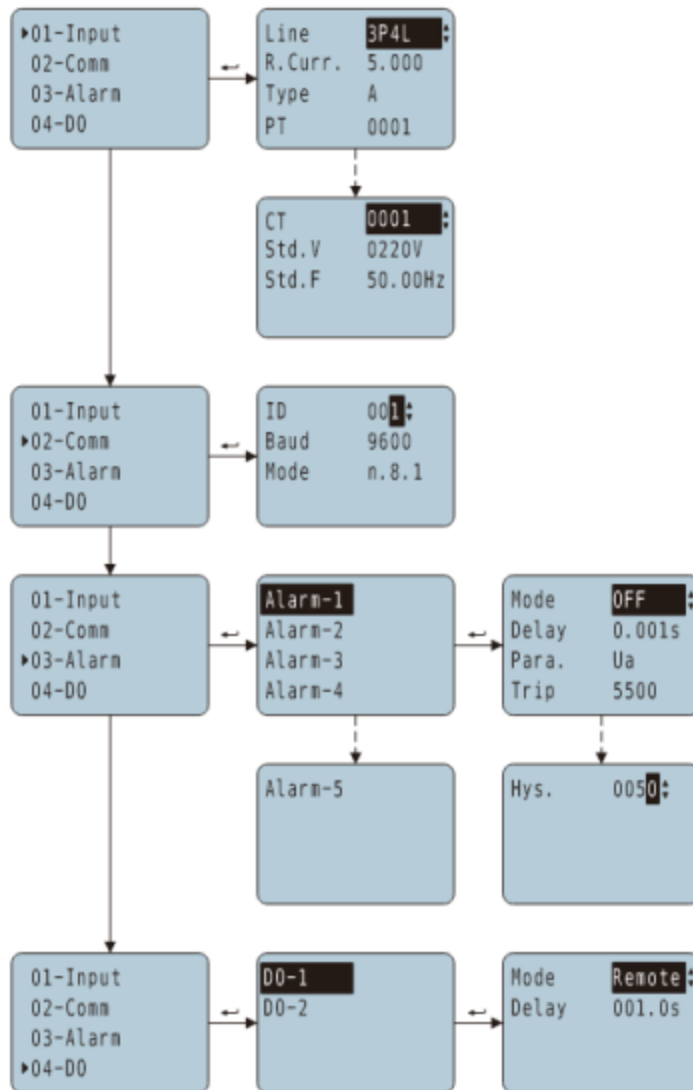

### Input signal setup

Power grid mode: default 3P4L <sup>(1)\*</sup>

Secondary current

Current Type: A/ mV

Voltage/ current transformer ratio <sup>(2)\*</sup>

Voltage/ frequency standard deviation

### Communication setup

Modbus address: 1-247

Comm. baud ratio

Comm. data format

### Alarm trig threshold setting

Alarm mode

Delay timer of the trig

Parameter be triggered

Trip value

Hysteresis value: default 0050

### Digital output setup

DO working mode: remote, auto trig, turned off

Delay timer of the trig

### Notes:

1. Wiring method default: 3P4L, optional: 2P3L, 3P3L3CT, 3P3L2CT, 1P2L1CT, and **1P2L3CT** will be specially specified when ordering, and this setting is invalid when the hardware does not support it. Three-channels single-phase meter may use 5A, 100mA, 333mV signal.

2. When the current signal is lower than 333mV, the CT value defaults to the primary side parameter.

The pulse output value defaults to 5000/kWh.

3. Blue Jay calibrates meter under 380V range, and high-quality linearity performance ensures that the meter can accurately measure in the lower voltage range. That can be compatible with 120V, 220V, 230V, 240V, 277V system.

*If need to use in different voltage scale or different types CT, please contact our sales team for*

more details.

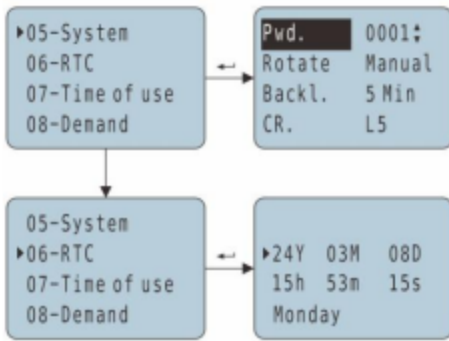

**System parameter setup**

- Password
- Page scroll method
- Duration of LCD backlight
- Color contrast

**Real-time clock setup**

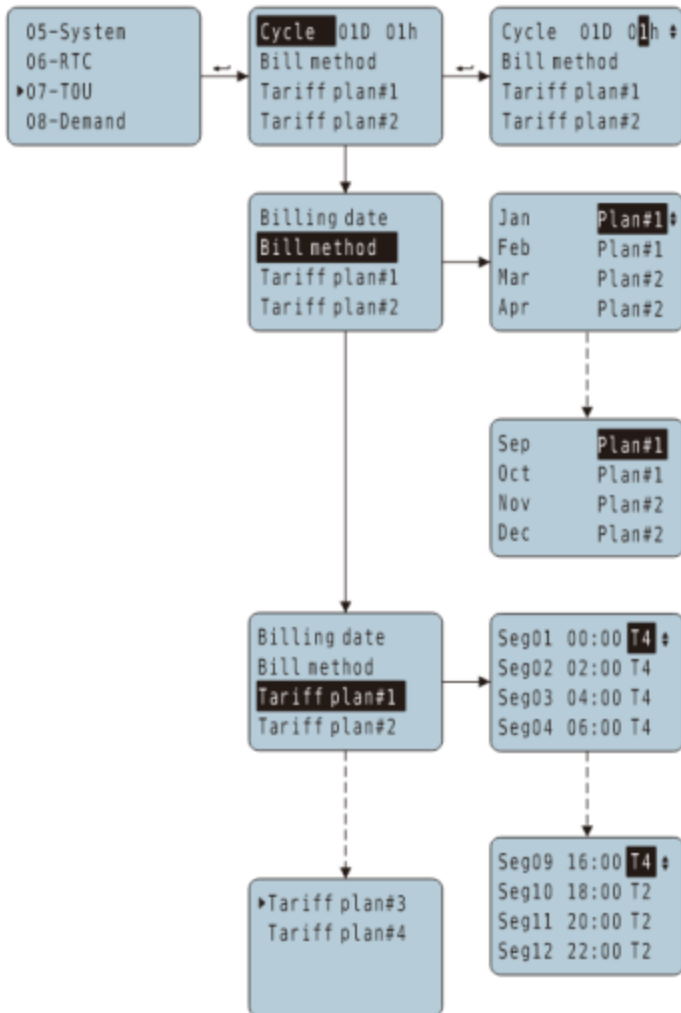

**TOU billing mode settings**

4 Tariff plans, 12 segments

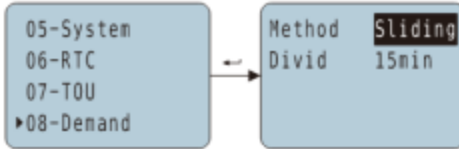

### Demands record setting

Calculate method: sliding window/ block  
Divide time:15 minutes

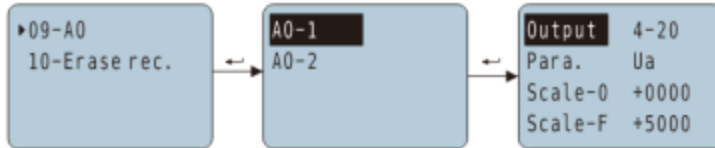

### Analog output setup

Analog output signal range  
Analog output signal parameter  
Zero-scale value  
Full-scale value

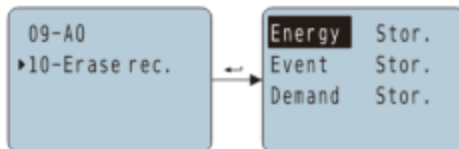

### Erase record setting

Erase energy records  
Erase event records  
Erase demand records

**(Note: optional storage or erase, need to save after setting.)**

## 7.- PULSE OUTPUT

APM-4MJ provides 1\* pulse output for the positive active energy.

The host / PLC / DI module can cumulative the data of both the active and reactive power energy sent by the pulse from opt coupler relay.

1). Electrical specification: voltage  $VCC \leq 48V$ ,  $I_z \leq 50mA$ .

2). Pulse: 5000 imp / kWh, pulse up to 80ms.

This means: When the device detects 1 kWh, the port will generate 5000 pulse.

**Note:** 1 kWh energy is for secondary side energy data, if there have PT and CT accessed; primary side energy data is "1 kWh  $\times$  PT ratio  $\times$  CT ratio".

Voltage (V)	Current (A)	Pulse constant (imp / kWh)
380 or 220	5	5000
	1	20000
100	5	20000
	1	80000

**Example:** In measure time "T", the received total pulse is "N",  
 Primary side input of voltage is 10Kv,  
 Primary side input of current is 400A.  
 Secondary side measurement range is 100V and 5A.

In the time "T", energy accumulated is:  $N / 20000 \times 100 \times 80$

## 8. - COMMUNICATION INTERFACE

### 8.1. - Connection for RS485 BUS

The composition of the RS-485 cabling must be carried out with a meshed Page cable (minimum 3 wire), diameter of not less than 0.5mm<sup>2</sup>, with a maximum distance of 1,200 m between the APM-4MJ and the master unit. This Bus may connect a maximum of 32pcs APM-4MJ...

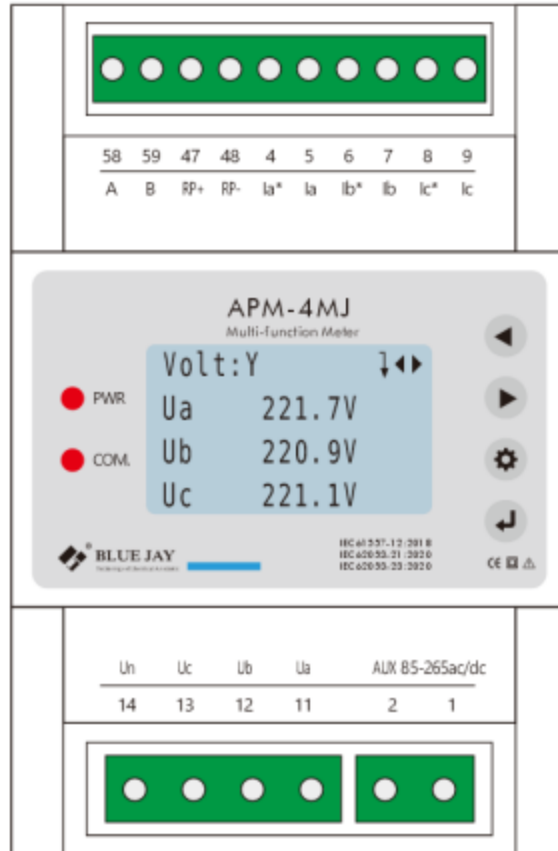

#### Notes:

- For communication with the master unit, user can choose RS-485 to RS-232 converter or RS485 to USB adapter to use.
- For expand the number of devices in the communication network, a signal repeater can be used.
- Full range of APM-4MJ... meter RS485 PIN number is 58,59.
- Due to product modifications or special requirements, the interface pin place may be change.  
For details, please refer to product label on the rear side.

## 8.2. - MODBUS © protocol

### Modbus RTU Frame Format:

<b>Address code</b>	<b>1 BYTE</b>	<i>Slave device address 1-247</i>
<b>Function code</b>	<b>1 BYTE</b>	<i>Indicates the function codes like read coils / inputs</i>
<b>Data code</b>	<b>4 BYTE</b>	<i>Starting address, high byte Starting address, low byte Number of registers, high byte Number of registers, low byte</i>
<b>Error Check code</b>	<b>2 BYTE</b>	<i>Cyclical Redundancy Check ( <b>CRC</b> )</i>

### MODBUS FUNCTIONS:

<b>Code</b>	<b>Meaning</b>	<b>Description</b>
<b>FUNCTION 01</b>	Read Coil Status	<i>Only valid when equipped DO port</i>
<b>FUNCTION 02</b>	Read Input Status	<i>Only valid when equipped DI port</i>
<b>FUNCTION 03</b>	Reading of n Words	<i>This function permits to read all the electrical parameters of the device.</i>
<b>FUNCTION 05</b>	Force Single coil	<i>When DO in remote control mode can work</i>
<b>FUNCTION 06</b>	Preset Single holding register	<i>There is an upper limit for writing, please be sure to check the upper limit of the host computer to avoid exhausting the life of the storage machine.</i>

**Note:** Float data follow **IEEE754**, float low bit first, high bit next. **(CD AB)**

### 8.3. - Register map

#### 8.3.1.- Basic power data-primary side

Register	Data	Byte mode		Instruction
0x00	Ua	float	2	Phase to line voltage, Unit: V
0x02	Ub	float	2	
0x04	Uc	float	2	
0x06	Uab	float	2	Phase to phase voltage, Unit: V
0x08	Ubc	float	2	
0x0a	Uca	float	2	
0x0c	Ia	float	2	Three phase current, Unit: A
0x0e	Ib	float	2	
0x10	Ic	float	2	
0x12	Pa	float	2	Total and split phase active power, Unit: kW
0x14	Pb	float	2	
0x16	Pc	float	2	
0x18	$P\Sigma$	float	2	
0x1a	Qa	float	2	Total and split phase reactive power, Unit: kVar
0x1c	Qb	float	2	
0x1e	Qc	float	2	
0x20	$Q\Sigma$	float	2	
0x22	Sa	float	2	Total and split apparent power, Unit: kVA
0x24	Sb	float	2	
0x26	Sc	float	2	
0x28	$S\Sigma$	float	2	
0x2a	PFa	float	2	Total and split power factor, 0~1.000
0x2c	PFb	float	2	
0x2e	PFc	float	2	
0x30	$PF\Sigma$	float	2	
0x32	FR	float	2	Frequency, Unit:0.01Hz
0x34	Ep+	float	2	Positive active energy, Unit: kWh
0x36	Ep-	float	2	Negative active energy, Unit: kWh
0x38	Eq+	float	2	Inductive reactive power, Unit: kVarh
0x3a	Eq-	float	2	Capacitive reactive power

0x3c	ES	float	2	Total apparent energy, unit: VAh
0x3e	EpA+	float	2	A phase positive active energy, unit: kWh
0x40	EpA-	float	2	A phase negative active energy
0x42	EqA+	float	2	A phase inductive reactive energy, unit: kVarh
0x44	EqA-	float	2	A phase capacitive reactive energy
0x46	ESA	float	2	A phase apparent energy, unit VAh
0x48	EpB+	float	2	B phase positive active energy, unit: kWh
0x4A	EpB-	float	2	B phase negative active energy
0x4C	EqB+	float	2	B phase inductive reactive energy, unit: kVarh
0x4E	EqB-	float	2	B phase capacitive reactive energy
0x50	ESB	float	2	B phase apparent energy, unit: VAh
0x52	EpC+	float	2	C phase positive active energy, unit: kWh
0x54	EpC-	float	2	C phase negative active energy
0x56	EqC+	float	2	C phase inductive reactive energy, unit: kVarh
0x58	EqC-	float	2	C phase capacitive reactive energy
0x5A	ESC	float	2	C phase apparent energy, unit: VAh
0x5C	Io	float	2	Real-time measurement zero-sequence current data, unit: A (Reserved function)

**8.3.2.- Basic power data-secondary side**

Register	Data	Byte		Instruction
0x100	Ua	int	1	Phase to line voltage, Unit: 0.1V
0x101	Ub	int	1	
0x102	Uc	int	1	
0x103	Uab	int	1	Phase to phase voltage, Unit: 0.1V
0x104	Ubc	int	1	
0x105	Uca	int	1	
0x106	Ia	int	1	Three phase Current, Unit: 0.001A
0x107	Ib	int	1	
0x108	Ic	int	1	
0x109	Pa	int	1	Total and split phase active power, Unit: kW
0x10a	Pb	int	1	
0x10b	Pc	int	1	
0x10c	$P\Sigma$	int	1	
0x10d	Qa	int	1	Total and split phase reactive power, Unit: kVar
0x10e	Qb	int	1	
0x10f	Qc	int	1	
0x110	$Q\Sigma$	int	1	
0x111	Sa	int	1	Total and split apparent power, Unit: kVA
0x112	Sb	int	1	
0x113	Sc	int	1	
0x114	$S\Sigma$	int	1	
0x115	PFa	int	1	Total and split power factor, 0~1.000
0x116	PFb	int	1	
0x117	PFc	int	1	
0x118	$PF\Sigma$	int	1	
0x119	FR	int	1	Frequency, Unit:0.01Hz
0x11a	Ep+	Int 32	2	Positive active energy, Unit: Wh
0x11c	Ep-	Int 32	2	Negative active energy, Unit: Wh
0x11e	Eq+	Int 32	2	Inductive reactive power, Unit:Varh
0x120	Eq-	Int 32	2	Capacitive reactive power
0x122	ES	int	2	Total apparent energy, unit: VAh
0x124	EpA+	int	2	A phase positive active energy, unit: kWh
0x126	EpA-	int	2	A phase negative active energy
0x128	EqA+	int	2	A phase inductive reactive energy, unit: kVarh
0x12A	EqA-	int	2	A phase capacitive reactive energy
0x12C	ESA	int	2	A phase total apparent energy, unit VAh

0x12E	EpB+	int	2	B phase positive active energy, unit: kWh
0x130	EpB-	int	2	B phase negative active energy
0x132	EqB+	int	2	B phase inductive reactive energy, unit: kVarh
0x134	EqB-	int	2	B phase capacitive reactive energy
0x136	ESB	int	2	B phase total apparent energy, unit: VAh
0x138	EpC+	int	2	C phase positive active energy, unit: kWh
0x13A	EpC-	int	2	C phase negative active energy
0x13C	EqC+	int	2	C phase inductive reactive energy, unit: kVarh
0x13E	EqC-	int	2	C phase capacitive reactive energy
0x140	ESC	int	2	C phase total apparent energy, unit: VAh
0x142	Io	int	1	Real-time measurement zero-sequence current data, unit: 0.001A (Reserved function)
0x143	Ang_Ua	int	1	A phase voltage angle, unit: 0.1 degree
0x144	Ang_Ub	int	1	B phase voltage angle
0x145	Ang_Uc	int	1	C phase voltage angle
0x146	Ang_Ia	int	1	A phase current angle
0x147	Ang_Ib	int	1	B phase current angle
0x148	Ang_Ic	int	1	C phase current angle

**8.3.3.- Meter status data**

Register	Data	Byte mode		Instruction
0x200	DO	int	1	Digital output: Bit 0~1 show channel 1 and channel 2 status 0 for open, 1 for closed
0x201	DI	int	1	Digital input: Bit 0~3 show channel 1 to channel 4 status 0 for open, 1 for closed
0x202	DZ	int	1	Alarm status Bit 0~4 show channel 1- channel 5 alarm status
0x20A	RTC. year	int	1	Internal RTC real time clock: Year - Month - Date - Hour - Minutes - Second-Week
0x20B	RTC. month	int	1	
0x20C	RTC. date	int	1	
0x20D	RTC. hour	int	1	
0x20E	RTC. minute	int	1	
0x20F	RTC. second	int	1	
0x210	RTC. week	int	1	

### 8.3.4.- Advanced electrical parameter - primary side

Register	Data	Byte mode		Instruction
0x300	Pd	float	2	Present active power demand, Unit: W
0x302	Qd	float	2	Present reactive power demand, Unit: var
0x304	Sd	float	2	Present apparent power demand, Unit: VA
0x306	Pd_M0	float	2	Maximum active power demand in present month
0x308	Qd_M0	float	2	Maximum reactive power demand in present month
0x30a	Sd_M0	float	2	Maximum apparent power demand in present month
0x30c	Pd_M1	float	2	Maximum active power demand in last month
0x30e	Qd_M1	float	2	Maximum reactive power demand in last month
0x310	Sd_M1	float	2	Maximum apparent power demand in last month
0x312	Pd_M2	float	2	Maximum active power demand in month before last month
0x314	Qd_M2	float	2	Maximum reactive power demand in month before last month
0x316	Sd_M2	float	2	Maximum apparent power demand in month before last month
0x318-0x31F	/	float	2	Reversed
0x320	U1	float	2	Positive sequence voltage in primary side
0x322	U2	float	2	Negative sequence voltage in primary side
0x324	U0	float	2	Zero sequence voltage in primary side
0x326	I1	float	2	Positive sequence current in primary side
0x328	I2	float	2	Negative sequence current in primary side
0x32A	I0	float	2	Zero sequence current in primary side
0x32C	$\epsilon U$	float	2	Voltage unbalance, $\epsilon U = (U2 / U1)\%$
0x32E	$\epsilon I$	float	2	Current unbalance, $\epsilon U = (I2 / I1)\%$
0x330	$\delta U_a$	float	2	A phase voltage deviation
0x332	$\delta U_b$	float	2	B phase voltage deviation
0x334	$\delta U_c$	float	2	C phase voltage deviation
0x336	$\delta F$	float	2	Frequency deviation

**8.3.5.- Tou/ Multi- tariffs ratio data**

Register	Data	Byte mode		Instruction
0x400	Sum	long	2	Total cumulative energy of M0+M1+M2
0x402	Sum _T1	long	2	T1-T4 cumulative Energy record
0x404	Sum _T2	long	2	
0x406	Sum _T3	long	2	
0x408	Sum _T4	long	2	
0x40a	M0_Sum	long	2	Total energy of this month
0x40c	M0_T1	long	2	T1-T4 Energy record of present month
0x40e	M0_T2	long	2	
0x410	M0_T3	long	2	
0x412	M0_T4	long	2	
0x414	M1_Sum	long	2	Total energy of last month
0x416	M1_T1	long	2	T1-T4 Energy record of last month
0x418	M1_T2	long	2	
0x41a	M1_T3	long	2	
0x41c	M1_T4	long	2	
0x41e	M2_Sum	long	2	Total energy of the month before last month
0x420	M2_T1	long	2	T1-T4 Energy record of the month before last month
0x422	M2_T2	long	2	
0x424	M2_T3	long	2	
0x426	M2_T4	long	2	

**8.3.6.- THD and individual harmonic (Max 63 times)**

Register	Data	Byte mode		Instruction
0x500	THDUa	int	1	A-phase voltage THD
0x501	THDUB	int	1	B-phase voltage THD
0x502	THDUC	int	1	C-phase voltage THD
0x503	THDIa	int	1	A-phase current THD
0x504	THDIb	int	1	B-phase current THD
0x505	THDIc	int	1	C-phase current THD
0x508-0x545	HUa	int	62	Three phase voltage individual harmonic 2 to 63 <sup>rd</sup>
0x548-0x585	HUB	int	62	
0x588-0x5c5	HUC	int	62	
0x5c8-0x605	HIa	int	62	Three phase current individual harmonic 2 to 63 <sup>rd</sup>
0x608-0x645	HIb	int	62	
0x648-0x685	HIc	int	62	
0x688	TOHDUa	int	1	Three phase voltage total odd harmonic distortion, unit 0.1%
0x689	TOHDUB	int	1	
0x68a	TOHDUC	int	1	
0x68b	TEHDUa	int	1	Three phase voltage total even harmonic distortion, unit 0.1%
0x68c	TEHDUB	int	1	
0x68d	TEHDUC	int	1	
0x68e	THFFUa	int	1	Three phase voltage telephone harmonic form factor, unit 0.1%
0x68f	THFFUb	int	1	
0x690	THFFUc	int	1	
0x691	CFUa	int	1	Three phase voltage crest factor, unit 0.001
0x692	CFUb	int	1	
0x693	CFUc	int	1	
0x694	TOHDIa	int	1	A phase current total odd harmonic distortion, unit 0.1%
0x695	TOHDIb	int	1	
0x696	TOHDIc	int	1	
0x697	TEHDIa	int	1	Three phase current total even harmonic distortion, unit 0.1%
0x698	TEHDIb	int	1	
0x699	TEHDIc	int	1	
0x69a	KFIa	int	1	Three phase current K factor, unit 0.01
0x69b	KFIb	int	1	
0x69c	KFIc	int	1	

**8.3.7.- SOE record**

Register	Data	Byte mode		Instruction
0x700-0x7F9	I/O event 10 list	int	5	Byte 0: Fault type Byte 1: Fault event Byte 2,3: Fault value Byte 4: Fault time: Year Byte 5: Fault time: Month Byte 6: Fault Time: Day Byte 7: Fault time: Time Byte 8: Fault time: Minute Byte 9: Fault time: Seconds
	Alarm event 50list			

Byte 0	Byte 1	
1:DI1 Closed 2:DI2 Closed 3:DI3 Closed 4:DI4 Closed  21:DI1 Opened 22:DI2 Opened 23:DI3 Opened 24:DI4 Opened  51: Alarm_1 tripped 52: Alarm_2 tripped 53: Alarm_3 tripped 54: Alarm_4 tripped 55: Alarm_5 tripped  61: Alarm_1 released 62: Alarm_2 released 63: Alarm_3 released 64: Alarm_4 released 65: Alarm_5 released  101:DO1 Closed 102:DO2 Closed  121:DO1 Opened 122:DO2 Opened	0: Remote control 1: DZ Alarm_1 2: DZ Alarm_2 3: DZ Alarm_3 4: DZ Alarm_4 5: DZ Alarm_5 6: Manually close DO 7: Manually open DO 100: Manually turn off DZ when tripped 101:UA upper alarm 102:UB upper alarm 103:UC upper alarm 104:UAB upper alarm 105:UBC upper alarm 106:UCA upper alarm 107:UA/UB/UC upper alarm 108:IA upper alarm 109:IB upper alarm 110:IC upper alarm 111:IA/IB/IC3 upper alarm 112:PA upper alarm 113:PB upper alarm 114:PC upper alarm 115:total active power upper alarm 116:QA upper alarm 117:QB upper alarm 118:QC upper alarm 119:total reactive power upper alarm 120:SA upper alarm 121:SB upper alarm 122:SC upper alarm 123:total apparent power upper alarm 124:total power factor upper alarm 125:frequency upper alarm 126:DI1 close alarm 127:DI2 close alarm 128:DI3 close alarm 129:DI4 close alarm 130:DI5 close alarm 131:DI6 close alarm	132:UA lower alarm 133:UB lower alarm 134:UC lower alarm 135:UAB lower alarm 136:UBC lower alarm 137:UCA lower alarm 138:UA/UB/UC lower alarm 139:IA lower alarm 140:IB lower alarm 141:IC lower alarm 142:IA/IB/IC3 lower alarm 143:PA lower alarm 144:PB lower alarm 145:PC lower alarm 146:total active power lower alarm 147:QA lower alarm 148:QB lower alarm 149:QC lower alarm 150:total reactive power lower alarm 151:SA lower alarm 152:SB lower alarm 153:SC lower alarm 154:total apparent power lower alarm 155:total power factor lower alarm 156:frequency lower alarm 157:DI1 open alarm 158:DI2 open alarm 159:DI3 open alarm 160:DI4 open alarm 161:DI5 open alarm 162:DI6 open alarm

**8.3.8.- Configuration menu (Function 03 to Read & Function 06 to Write)**

Register	Data	Byte mode		Instruction	
0x20A	RTC. year	int	1	Internal RTC real-time time: year-month-day-hour-minute-second-week	
0x20B	RTC. month	int	1		
0x20C	RTC. date	int	1		
0x20D	RTC. hour	int	1		
0x20E	RTC. minute	int	1		
0x20F	RTC. second	int	1		
0x210	RTC. week	int	1		
0x900	Line	int	1	Wiring method: 0: 3-phase 4-line 1: 3-phase 3- line 2CT 2: 3-phase 3- line 3CT	
0x901	U.SCL	int	1	Voltage range 0:100V 1:380V	
0x902	I.SCL	int	1	Current range 0:1A 1:5A	
0x903	PT	int	1	Voltage ratio: range 1-9999 (The direct access type is 1 and cannot be changed).	
0x904	CT	int	1	Current ratio: range 1-9999 (The direct access type is 1 and cannot be changed).	
0x905	RS485 address	int	1	1-247	
0x906	Baud rate	int	1	0: 2400 1: 4800	2: 9600 3: 19200
0x907	Data format	int	1	0: n.8.1 1: o.8.1	2: e.8.1 3: n.8.2
0x2000	Reset energy	int	1	Write 0x0A0A, (2570) for reset	
0x3000	Reset SOE	int	1		
0x4000	Reset demand	int	1		

**Notes:**

1. Not all of the data above can be read by RS485, the reading address will be unsuccessful.
2. The data can be read out depends on your multi-function meter model, please refer to the corresponding product manual before build your software.
3. Some software has different definitions of the start bit of register address, there will be offset, please add 1 for the right address. To get more info, please contact technical support [tech@cqbluejay.com](mailto:tech@cqbluejay.com)

## 8.4.- Example

### Host inquiry slave device

Addr.	Func.	Data Address (high)	Data Address (low)	Data Number (high)	Data number (low)	CRC16 (low)	CRC16 (high)
0CH	03H	00H	00H	00H	06H	C4H	D5H

*PC user ask upload UA, UB, UC, IA, IB, IC*

### Slave device answer

Addr.	Func.	Byte count	Data1 high	Data1 low	Data2 high	Data2 low	Data3 high	Data3 low
0CH	03H	0CH	03H	E8H	03H	E9H	03H	E8H
Data4 high	Data4 low	Data5 high	Data5 low	Data6 high	Data6 low	CRC16 low	CRC16 high	
13H	84H	13H	88H	13H	8AH	A6H	D6H	

#### Show the data:

UA=3E8H (100.0)

UB=3E9H (100.1)

UC=3E7H (99.9)

IA=1384H (4.996)

IB=1388H (5.000)

IC=138AH (5.002)

#### Notes:

1. Blue Jay disable the 06 function in default setting, if Activated the write command, please check the host device program to avoid the meaningless write operation, that may reduce the reduce the register working life.
2. When the write is unsuccessful, no return data from the slave device. In this addition, please re-send write inquiry again.

## 9.- SAFETY CONSIDERATIONS



All installation specification described at the previous chapters named:  
**INSTALLATION AND STARTUP, INSTALLATION MODES and SPECIFICATIONS.**

Please note that with the instrument powered on, the terminals could be dangerous to touching and cover opening actions or elements removal may allow accessing dangerous parts. This instrument is factory-shipped at proper operation condition.

- ◆ The device must have a professional installation and maintenance.
- ◆ Any operation of the device, you must cut off the input signal and power.

## 10.- MAINTENANCE

The APM-4MJ meter does not require any special maintenance. No adjustment, maintenance or repairing action should be done when the instrument is open and powered on, should those actions are essential, high-qualified operators must perform them.

Before any adjustment, replacement, maintenance or repairing operation is carried out, the instrument must be disconnected from any power supply source.

When any protection failure is suspected to exist, the instrument must be immediately put out of service. The instrument's design allows a quick replacement in case of any failure.

## 11. - TECHNICAL SERVICE

### FAQ's

- 1.- Once cabled and connected is seen to give a correct voltage and current reading, but shows negative values for active power (generation).

This is an error with the cabling for the current transformer secondary; the direction of the transformer current has to be respected as shown in the connection diagram. The current transformers have a two face primary; the current must pass from P1 to P2 giving the result in secondary (S1 and S2) of 5 amps.

The error stems from:

- a). The current transformers have been incorrectly installed. As a result, it gives the direction of the current as passing from P2 to P1; to resolve this problem, the current transformer does not have to be dismantled and installed again, but the transformer secondary (S1 and S2) just has to be inverted.
  - b). The connection of the current secondary in the current transformers have been incorrectly connected; to resolve this problem just connect the S1 transformer secondary to the S1 on the meter and the S2 on the current transformer to the S2 on the meter.
- 2.- Once cabled and connected, is seen to give an incoherent Power factor and Cos $\Phi$  reading (-0.01 or similar).

This is again a current transformer and voltage phase connection error phase A, must correspond to the current transformer installed in phase A; phase B, must correspond to the current transformer installed in phase B; and phase C, must correspond to the current transformer installed in phase C.

This connection terminal is clearly shown on the area side of the device.

- 3.- The measuring voltage and is displaying the secondary voltage (for example 110 volts). Ensure that the voltage Transformer ratio has been correctly set (Please refer to voltage PT ratio setting section in chapter **SETUP PROCEDURE**).
- 4.- Device does not correctly display the current reading. It shows values varying between 0 to 5 amps of current. Ensure that the Current Transformer ratio has been correctly set; (Please refer to current CT ratio setting section in chapter **SETUP PROCEDURE**).

**Calculation formula of electrical parameter**

Formula	Parameter
$U = \sqrt{\frac{1}{N} \sum_{n=0}^N u_n^2} \quad n = 0, 1, 2, \dots, N$	Voltage RMS value
$I = \sqrt{\frac{1}{N} \sum_{n=0}^N i_n^2} \quad n = 0, 1, 2, \dots, N$	Current RMS value
$P = \frac{1}{N} \sum_{n=1}^N (i_{an} u_{an} + i_{bn} u_{bn} + i_{cn} u_{cn})$	Total active power cycle average
$P_s = UI$	Single-phase apparent power cycle average
$\cos \theta = \frac{P_p}{P_s}$	Power factor
$P_q = \sqrt{P_s^2 - P_p^2}$	Reactive power (Pq is positive and the direction cannot be determined; P algorithm can be used to shift the voltage component by 90°)
$W = \int P * dt$	Electric energy

**Note:** In above formula, N for sampling points in one AC wave, In standard APM-4MJ, the N=128

For any inquiry about the instrument performance or any failure, contact to Blue Jay's technical service.

*Blue Jay - After-sales service*

E-mail: [tech@cqbluejay.com](mailto:tech@cqbluejay.com)