

# SCM-PDS3

## Partial Discharge Sensor

### User Manual

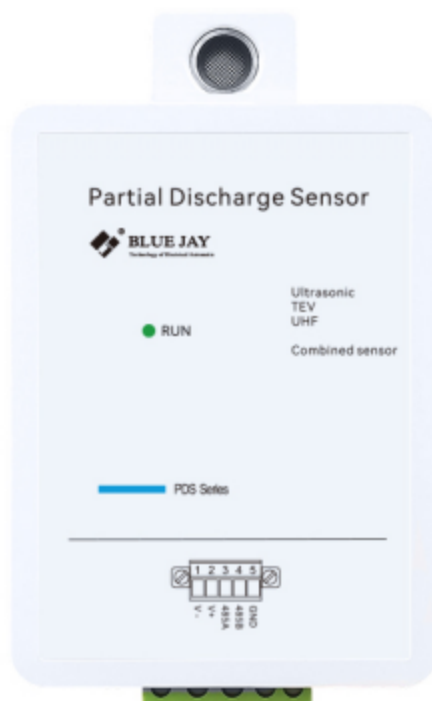

**Version:1.12**

**Revision: 2026.06**

## Read me

**When you use SCM-PDS3 partial discharge sensor, be sure to read this user manual carefully, and be able to fully understand the implications, the correct guidance of operations in accordance with user manual, which will help you make better use of SCM-PDS3 partial discharge sensor, and help to solve the various problems at the scene.**

1. Always keep safe distance between the high voltage part and the instrument, probe and operator.
2. Measurements must not be taken when thunderstorms are nearby.
3. Do not operate the instrument or accessories in explosive atmospheres.
4. After the battery alarm of the instrument, please turn off the power to charge.
5. Do not open the instrument without permission, this will affect the warranty of the product. The factory is not responsible for self-disassembly.
6. When the instrument is transported, it should avoid rain erosion and prevent collision and falling.
7. When storing and keeping the instrument, attention should be paid to the ambient temperature and humidity, and it should be protected from dust, moisture, shock, acid, and corrosive gas.



- **Please read this user manual carefully**
- **Please save this document**

## Directory

<b>1.- SUMMARIZE .....</b>	<b>- 1 -</b>
<b>2.- TECHNICAL SPECIFICATION .....</b>	<b>- 2 -</b>
<b>3.- FUNCTION INTRODUCTION .....</b>	<b>- 3 -</b>
3.1.- PD MEASUREMENT TECHNOLOGY INTRODUCTION .....	- 3 -
3.2.- PD PATTERN ANALYSIS FUNCTION INTRODUCTION .....	- 6 -
<b>4.- INSTALLATION AND START-UP .....</b>	<b>- 8 -</b>
4.1.- DIMENSION .....	- 8 -
4.2.- TERMINAL DEFINITION .....	- 8 -
4.3.- PD SENSOR MOUNTING METHOD .....	- 9 -
<b>5.- COMMUNICATION INTERFACE .....</b>	<b>- 10 -</b>
5.1.- MODBUS © PROTOCOL .....	- 10 -
5.2.- REGISTER MAP .....	- 12 -
5.2.1.- READ THE SETTING VALUE, READ ONLY FUN 03 TO READ .....	- 12 -
5.2.2.- READ THE COLLECTED VALUES FROM THE DEVICE, READ ONLY FUN 04 TO READ .....	- 12 -
5.2.3.- WRITE THE SETTING VALUE, WRITE ONLY FUN 06 TO WRITE .....	- 14 -
5.2.4.- WRITE THE MULTIPLE SETTING VALUE, WRITE ONLY FUN 10 TO WRITE .....	- 14 -
5.2.5.- READ PD PATTERN DATA, READ ONLY FUN 64, 65, 66 TO READ .....	- 16 -
<b>6.- SAFETY CONSIDERATIONS .....</b>	<b>- 18 -</b>
<b>7.- TECHNICAL SERVICE .....</b>	<b>- 18 -</b>

## 1.- SUMMARIZE

Partial discharge sensors are critical for assessing power equipment insulation integrity. PD signals (weak electrical pulses) serve as early indicators of insulation deterioration, which can escalate into catastrophic failures if undetected. The SCM-PDS3 sensor integrates three PD detection methods: Ultrasonic (AA), Transient Earth Voltage (TEV), and Ultra-High Frequency (UHF) delivering a comprehensive monitoring solution for medium/high-voltage equipment including transformers and switchgears.

Additionally, it incorporates ambient noise, temperature, and humidity monitoring to eliminate environmental interference and enhance diagnostic accuracy. Compact and highly portable, the PDS3 features rapid measurements, exceptional anti-interference capability, and supports data upload via its integrated RS-485 interface, making it an all-in-one solution for field-based condition assessment.

### FEATURES

- Rugged, compact design;
- Non-intrusive detection method;
- Strong magnets to attach sensor;
- Rapid detection of partial discharge conditions;
- Suitable for extreme environment, outdoor substation;
- Measures PD in high-frequency UHF range;
- Ensures sensitive PD measurements in noisy environments;
- RS485, Modbus-RTU, SCADA systems.

### APPLICATIONS

- Substations, switchgear, transformers;
- Large-scale power generation facilities;
- Photovoltaic inverters, collector lines;
- Key motors, power distribution systems;
- UPS systems, key distribution cabinets, bus ducts;
- Commercial center power distribution.

## 2.- TECHNICAL SPECIFICATION

### Sensor common

Power supply	24VDC
Static power consumption	<10mW
Installation method	4* strong magnet, wall mount
Data sampling period	1S
PD pattern refresh period	2S
Communication	RS485/ Modbus RTU
Dimension	134mm*100*42mm
Operating temperature	-40~85°C

### Ultrasonic sensor (AA)

Detect range	0 ~ 60dB $\mu$ V
Resolution / Accuracy	1dB $\mu$ V
Pass band	Center frequency 40 kHz, $\pm$ 1 kHz

### TEV sensor

Detect range	0~60dBmV
Pass band	3~100MHz
Resolution / Accuracy	1dBmV / $\pm$ 1dBmV

### UHF sensor

Detect range	-70~10dBm
Pass band	300~1500MHz
Average effective height	$\geq$ 10mm

### Environmental sensors

Noise detection range	30~80dB (Class C)
Temp. measurement range	-40~85°C; Accuracy $\pm$ 0.5°C
Humidity measurement range	5~95%RH°; Accuracy $\pm$ 2%RH

### 3.- FUNCTION INTRODUCTION

#### 3.1.- PD measurement technology introduction

##### - Ultrasonic measurement (AA)

Partial discharges generate acoustic signals (20-200kHz) through mechanical stress oscillations in dielectrics. This sensor employs piezoelectric ceramic elements to detect vibrations via surface coupling with cabinet structures. Maintaining intimate contact with the cabinet surface is essential for optimal acoustic wave transmission efficiency, making it suitable for surface discharge monitoring in switchgear.

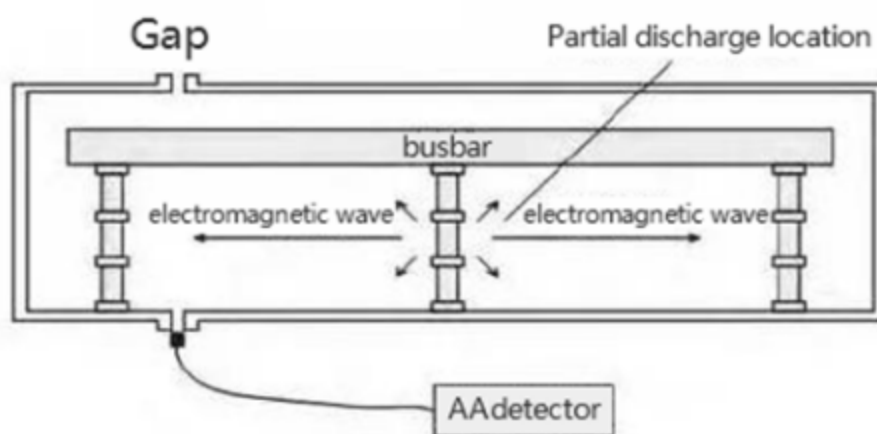

Figure 1. Ultrasonic detection mechanism

##### Insulation condition of switchgear:

Data	Definition
-6~0dB $\mu$ V, no discharge sound	No partial discharge.
0 ~ 60dB $\mu$ V, short discharge sound	Slight discharge, and attention should be paid to it later.
Above 60dB $\mu$ V, have discharge sound	Obvious discharge, should be judged in combination with TEV.

##### Note:

The demarcation point (60dB $\mu$ V) is slightly different in different regions, so it is recommended to use 60dB $\mu$ V as the demarcation point, so that the operating status of the switchgear can be warned in advance.

**- TEV measurement**

Partial discharges excite 3-100MHz electromagnetic waves on metal cabinet surfaces, which convert to Transient Earth Voltage (TEV) at insulation discontinuities. Utilizing capacitive coupling sensors for non-intrusive signal acquisition, TEV amplitude correlates with discharge magnitude and attenuation along the propagation path. This method is specifically designed for surface discharge detection in metal-enclosed equipment.

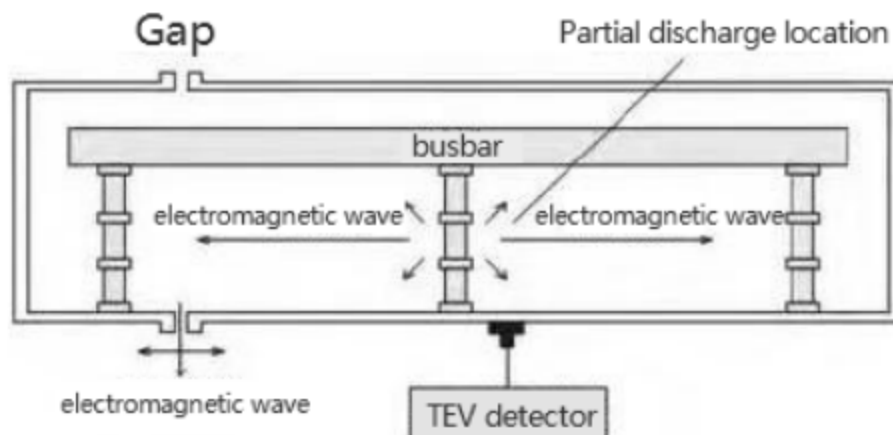

**Figure 2. TEV detection mechanism**

**Insulation condition of switchgear:**

Data	Definition
The reading is <20dB.	No partial discharge,
The reading is 20-29dB.	Slight discharge.
The reading is 29-40dB.	Moderate partial discharge should report and shorten the inspection cycle.
The reading is 40-50dB.	Serious partial discharge should report and shorten the inspection cycle, and be checked when power failure.
The reading is 50-60dB.	Severe partial discharge, power outage and maintenance as soon as possible.

## -. UHF measurement

This technique detects nanosecond-scale discharge pulses (<1ns rise time) by capturing 300MHz-3GHz electromagnetic waves, effectively avoiding corona interference below 300MHz. With high sensitivity and anti-interference capabilities, UHF enables discharge source localization and insulation defect classification. It is particularly effective for internal discharge detection in power transformers and other dielectric media, mitigating the bandwidth constraints of acoustic and TEV methods.

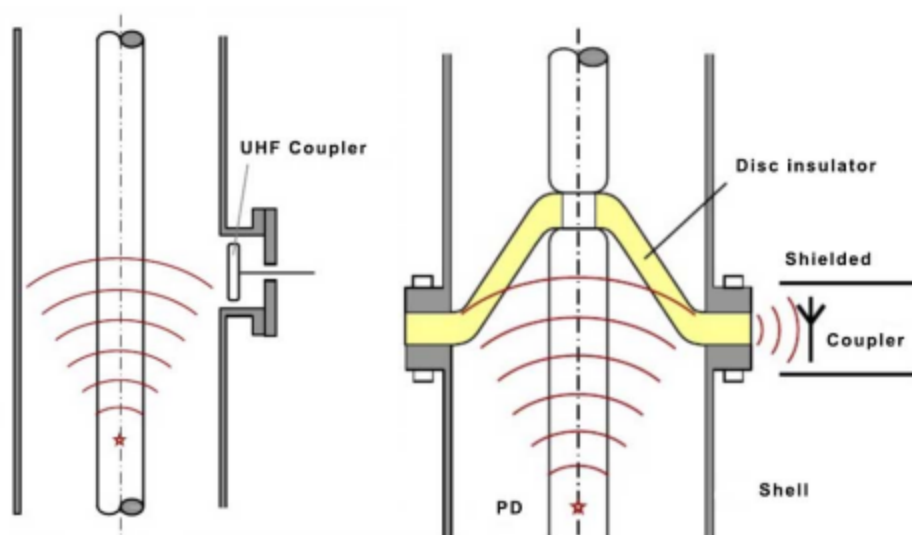

**Figure 3. UHF detection mechanism**

### Note:

All the above sensors are connected through the sensor extension port at the bottom of the host. When the sensor is connected through the same extension port, the host will automatically identify the sensor type, select the sampling channel of the corresponding frequency, and display the relevant parameters of the sensor on the top of the interface.

### 3.2.- PD Pattern analysis function introduction

This device enables real-time data acquisition and pattern upload, the internal refresh frequency is 2 seconds. When monitoring data triggers an alarm, alarm validity verification is performed via:

**PRPD** patterns: (2D phase-amplitude mapping for discharge phase distribution analysis)

**PRPS** patterns: (3D phase-time-amplitude mapping for pulse sequence evolution analysis)

Patterns are constructed from 1-second data packets, each comprising 50 cycles of 50Hz power frequency. Through analysis of discharge cluster morphology and phase correlation characteristics, the system can distinguish genuine partial discharges from electromagnetic interference and diagnoses insulation defects including corona, surface discharge, and internal voids. Typical pattern examples are shown below:

#### - Non-periodic discharge patterns

Characterized by high-amplitude discharges with weak correlation to 50Hz/100Hz phases, requiring closer scrutiny for potential floating discharge or random noise sources.

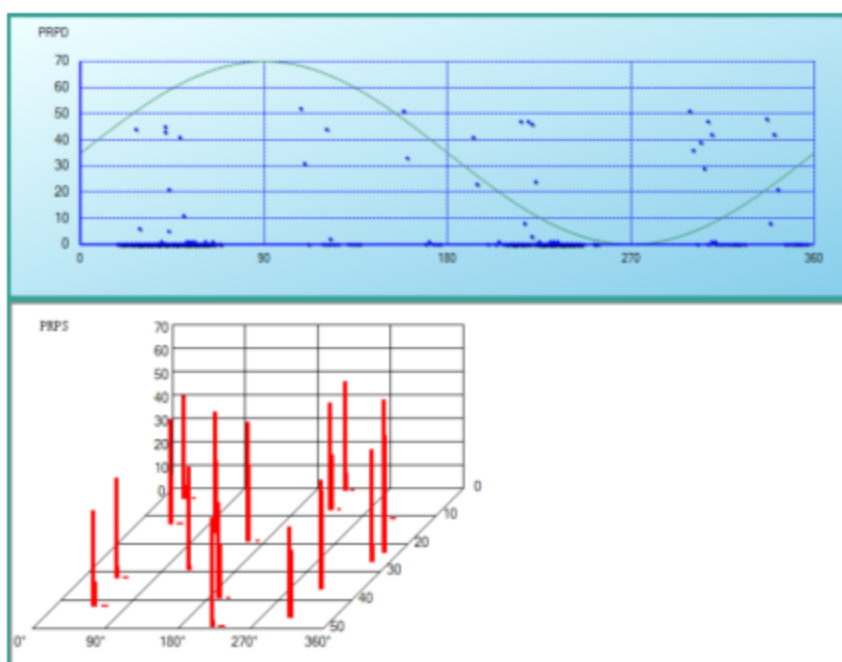

**- Power-frequency synchronous patterns (50Hz)**

Exhibits one discharge cluster per power frequency cycle, demonstrating typical power-frequency correlated features analogous to corona discharge (e.g., sharp electrode emissions).

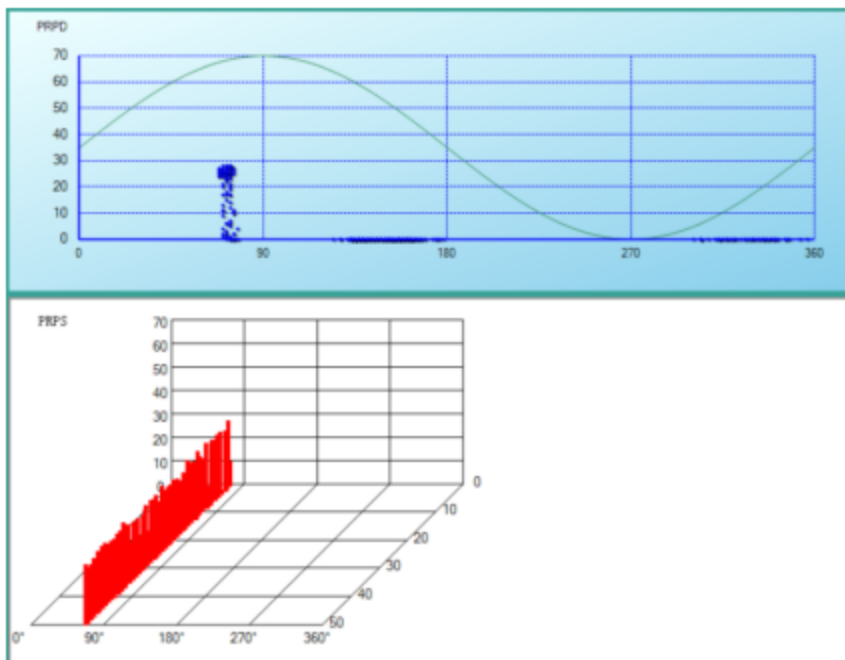

**- Harmonic-synchronous patterns (100Hz)**

Shows two discharge clusters per power cycle phase-separated by 180°, indicating strong 100Hz harmonic correlation consistent with internal voids or surface tracking discharges.

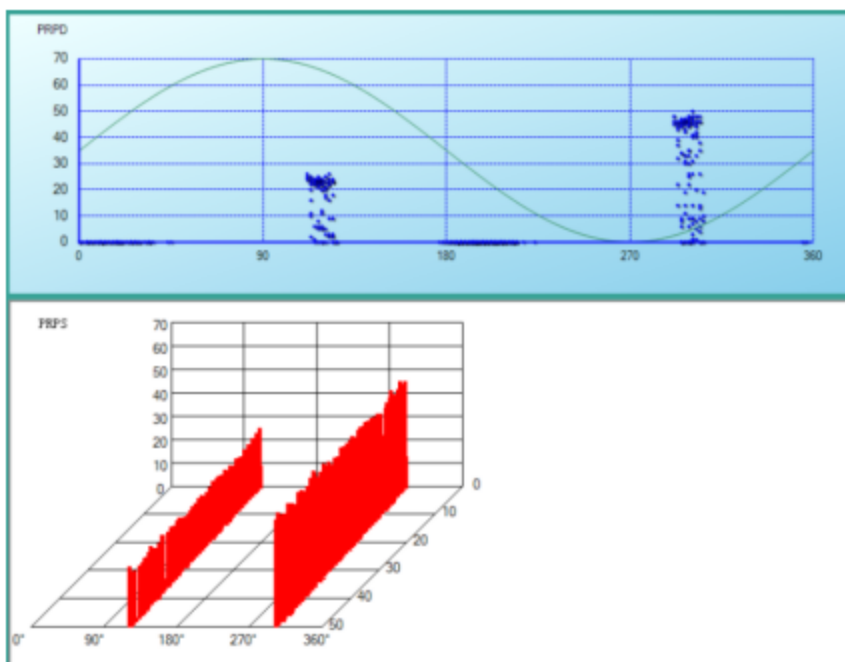

## 4.- INSTALLATION AND START-UP

### 4.1.- Dimension

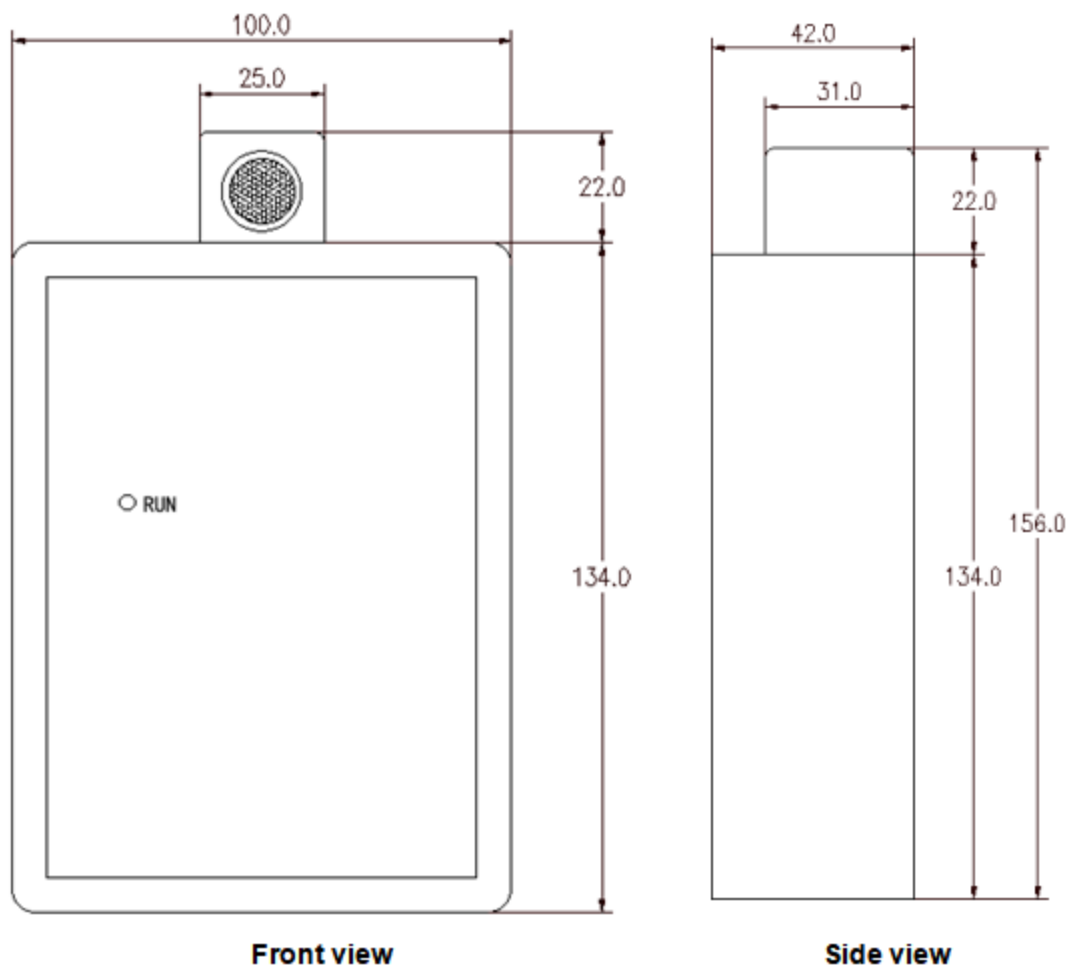

### 4.2.- Terminal definition

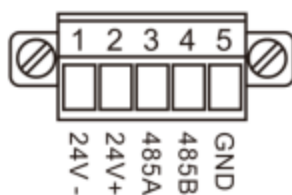

No.	Marked	Notes
1-2	24V +/-	Power supply
3-4	RS485 +/-	Communication interface
5	GND	Grounding

### 4.3.- PD sensor mounting method

The sensor is equipped with a highly sensitive microphone on top to collect ultrasonic signals from the switchgear. Depending on the application scenario, the microphone's orientation can be adjusted for optimal detection results, by default, the sensor is factory-set to face forward.

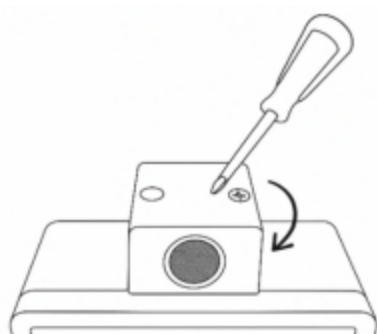

#### Method-1: Mounting on switchgear surface



When sensor is mounted on switchgear surface, the microphone must be rotated close to the cabinet, ensuring closely contact. that can enable the microphone to effectively capture ultrasonic signals.

#### Method-2: Mounting on switchgear inside



When sensor is mounted inside the switchgear, the microphone must face the switchgear interior to directly receive the ultrasonic signals.

## 5.- COMMUNICATION INTERFACE

This document defines the communication protocol specification of SCM-PDS3, please strictly follow this communication protocol to connect with the device. Default slave address 001, baud rate 9600, data bits 8, parity bit N, stop bit 1.

### 5.1.- MODBUS © protocol

#### Modbus RTU Frame Format:

##### Host inquiry:

<b>Address code</b>	<b>1 BYTE</b>	Slave device address
<b>Function code</b>	<b>1 BYTE</b>	Function codes
<b>Data code</b>	<b>4 BYTES</b>	Starting address, high byte Starting address, low byte Number of registers, high byte Number of registers, low byte
<b>Error Check code</b>	<b>2 BYTES</b>	Cyclical Redundancy Check ( <b>CRC</b> )

##### Slave response:

<b>Address code</b>	<b>1 BYTE</b>	Slave device address
<b>Function code</b>	<b>1 BYTE</b>	Function codes
<b>Data length</b>	<b>N</b>	Total data length
<b>Data range</b>	<b>-</b>	Data Area
<b>Error Check code</b>	<b>2 BYTES</b>	Cyclical Redundancy Check ( <b>CRC</b> )

**MODBUS FUNCTIONS**

<b>Code</b>	<b>Meaning</b>	<b>Description</b>
<b>FUNCTION 03</b>	<b>Read holding register</b>	Read device setting data
<b>FUNCTION 04</b>	<b>Read input register</b>	Read device measurement data
<b>FUNCTION 06</b>	<b>Write single register</b>	Writes a value into a single holding register.
<b>FUNCTION 10</b>	<b>Write multiple register</b>	Writes values into multiple holding registers
<b>FUNCTION 64</b>	<b>Read TEV value</b>	Read TEV value and phase angle
<b>FUNCTION 65</b>	<b>Read AA value</b>	Read AA value and phase angle
<b>FUNCTION 66</b>	<b>Read UHF value</b>	Read UHF value and phase angle

**Note:**

Starting address:0X0000, the first byte is the high bit, and the second byte is the low bit.

## 5.2.- Register Map

### 5.2.1.- Read the setting value, read only, Fun 03 to read.

Reg.	Data	Byte mode		Value range
0x00	Device address	INT	1	1-255
0x01	Baud rate	INT	1	1: 4800; 2:9600 <b>(Default)</b> 3:19200; 4:38400; 5:115200
0x02	AA setting value	INT	1	0~60, unit: dBuV
0x03	TEV setting value	INT	1	0~60, unit: dBmV
0x04	UHF setting value	INT	1	-70~10, unit: dBm
0x05	AA discharge times	INT	1	0-500
0x06	TEV discharge times	INT	1	0-500
0x07	UHF discharge times	INT	1	0-500

### 5.2.2.- Read the collected values from the device, read only, Fun 04 to read.

Reg.	Data	Byte mode		Value range
0x00	AA discharge times	INT	1	0-4095
0x01	AA discharge amplitude	INT	1	0~60, unit: dBuV
0x02	AA discharge average value	INT	1	0~60, unit: dBuV
0x03	AA alarm status	INT	1	0-normal; 1-alarm
0x04	TEV discharge times	INT	1	0-4095
0x05	TEV discharge amplitude	INT	1	0~60, unit: dBmV
0x06	Environmental noise value	INT	1	0~60, unit: dBmV
0x07	TEV alarm status	INT	1	0-normal; 1-alarm
0x08	UHF discharge times	INT	1	0-4095
0x09	UHF discharge amplitude	INT	1	-70~10, unit: dBm
0x0A	UHF discharge average value	INT	1	-70~10, unit: dBm
0x0B	UHF alarm status	INT	1	0-normal; 1-alarm
0x0C	Noise value	INT	1	30~80, unit: dB
0x0D	Temperature	INT	1	-40~85, unit: °C
0x0E	Humidity	INT	1	5~95, unit: %RH

**Note:**

UHF related values read from register are stored in **16-bit two's complement format**, positive numbers represent themselves, while negative numbers must be converted from two's complement to signed decimal to obtain the actual value.

**Command example:****Example 1: Read the device baud rate (By function 03)**

Host inquiry        01 03 00 01 00 01 D5 CA

Slave response    01 03 02 00 02 39 85

**This means the device baud rate is 02: 9600.**

**Example 2: Broadcast address query (By function 03)**

Host inquiry        00 03 00 00 00 01 85 DB

Slave response    00 03 02 00 03 C5 85

**This means the address is 003.**

**Example 3: Read the TEV discharge times (By function 04)**

Host inquiry        01 04 00 04 00 01 70 0B

Slave response    01 04 02 00 00 B9 30

**This means the TEV discharge times is 0.**

### 5.2.3.- Write the setting value, write only, Fun 06 to write.

Reg.	Data	Byte mode		Value range
0x00	Device address	INT	1	1-255
0x01	Baud rate	INT	1	1: 4800; 2:9600 <b>(Default)</b> 3:19200; 4:38400; 5:115200
0x02	AA setting value	INT	1	0~60, unit: dBuV
0x03	TEV setting value	INT	1	0~60, unit: dBmV
0x04	UHF setting value	INT	1	-70~10, unit: dBm
0x05	AA discharge times	INT	1	0-500
0x06	TEV discharge times	INT	1	0-500
0x07	UHF discharge times	INT	1	0-500

### 5.2.4.- Write the multiple setting value, write only, Fun 10 to write.

Reg.	Data	Byte mode		Value range
0x00	Device address	INT	1	1-255
0x01	Baud rate	INT	1	1: 4800; 2:9600 <b>(Default)</b> 3:19200; 4:38400; 5:115200
0x02	AA setting value	INT	1	0~60, unit: dBuV
0x03	TEV setting value	INT	1	0~60, unit: dBmV
0x04	UHF setting value	INT	1	-70~10, unit: dBm
0x05	AA discharge times	INT	1	0-500
0x06	TEV discharge times	INT	1	0-500
0x07	UHF discharge times	INT	1	0-500

#### Notes:

#### 1.- Initial alarm logic (alarm are triggered independently when each condition is met.):

When AA reach set threshold 30dBuV and simultaneous discharge count exceeds 10 pulses.

When TEV reach set threshold 30dBuV and simultaneous discharge count exceeds 10 pulses.

When UHF reach set threshold -30dBm and simultaneous discharge count exceeds 10 pulses.

#### 2.- UHF negative threshold values (e.g., -30 dBm) must be converted to 16-bit two's complement format before writing to the register.

#### 3.- Noise value refers to the environmental noise value, only for user reference, not to participate in the calculation of AA and TEV measurement value.

**Command example:****Example 1: Write the AA setting value to 50 (By function 06)**

Host inquiry      01 06 00 02 00 32 A9 DF

Slave response    01 06 00 02 00 32 A9 DF

**Example 2: Write the AA, TEV, and UHF setting value to 50 (By function 10)**

Host inquiry      01 10 00 02 00 03 06 00 32 00 32 00 32 5E 94

Slave response    01 10 00 02 00 03 21 C8

### 5.2.5.- Read PD pattern data, read only, Fun 64, 65, 66 to read.

Phase angle range: 0-200, with a phase resolution of 1.8°.

Each data point is stored in one register: the high 8 bits (H8) represent the phase angle (which should be multiplied by 1.8° to get the actual value), and the low 8 bits (L8) represent the discharge amplitude.

#### Function 64 to read TEV pattern data: amplitude value range: 0~60.

Register	Definition
0	Sample point 1 H8: Phase angle; L8: Discharge amplitude
1	Sample point 2 H8: Phase angle; L8: Discharge amplitude
...	
499	Sample point 500 H8: Phase angle; L8: Discharge amplitude

#### Function 65 to read AA pattern data: amplitude value range: 0~60.

Register	Definition
0	Sample point 1 H8: Phase angle; L8: Discharge amplitude
1	Sample point 2 H8: Phase angle; L8: Discharge amplitude
...	
499	Sample point 500 H8: Phase angle; L8: Discharge amplitude

#### Function 66 to read UHF pattern data: amplitude value range: 0~80.

Register	Definition
0	Sample point 1 H8: Phase angle; L8: Discharge amplitude
1	Sample point 2 H8: Phase angle; L8: Discharge amplitude
...	
499	Sample point 500 H8: Phase angle; L8: Discharge amplitude

**Note: UHF range is -70 dBm to 10 dBm. During parsing: Actual = L8 - 70.**

**Example: L8 = 60 → Actual is 60-70 = -10 dBm.**

**Command example: Read the AA pattern data of sample point 1-500 (By function 65)**

Host inquiry            01 65 00 00 01 F4 4D D5

Slave response        01 65 03 E8 10 00 10 00 10 00 10 00 10 00 74 3C 78 35 8C 22 8C 00 8C  
00 ..... 42 69

**Message description:**

**01** = device address, **65** = function code, **03 E8** = data length (1000 bytes). Each byte pair represents one data point, total 500 points.

**Means:**

Point 1 data=10 00 (10=16\*1.8° actual phase 28.8°. 00=0, actual amplitude 0)

Point 2 data =10 00 (10=16\*1.8° actual phase 28.8°. 00=0, actual amplitude 0)

....

## 6.- SAFETY CONSIDERATIONS



All installation specification described at the previous chapters named: **INSTALLATION AND STARTUP, INSTALLATION MODES and SPECIFICATIONS.**

Please note that with the instrument powered on, the terminals could be dangerous to touching and cover opening actions or elements removal may allow accessing dangerous parts. This instrument is factory-shipped at proper operation condition.

- ◆ The device must have a professional installation and maintenance.
- ◆ Any operation of the device, you must cut off the input signal and power.

## 7.- TECHNICAL SERVICE

For any inquiry about the instrument performance or whether any failure happens, contact to Blue Jay's technical service.

*Blue Jay - After-sales service*

*1802, Building 2, No.88, Jianxin East Road,  
Chongqing,400020, China*

*Tel - + 0086 023 67628702  
E-mail: tech@cqbluejay.com*