

APM-96Y(E)

Multi-Function Power Meter

User Manual



Version: 1.10

Revision: 2024.12

Read me

When you use APM-96Y multi-function meter, be sure to read this user manual carefully, and be able to fully understand the implications, the correct guidance of operations in accordance with user manual, which will help you make better use of APM-96Y multi-function meter, and help to solve the various problems at the scene.

1. Before the meter turning on the power supply, be sure that the power supply within the provisions of the instrument;
2. When installation, the current input terminal must non-open, voltage input terminals must Non-short circuit;
3. Communication terminal (RS232/RS485 or Ethernet) is strictly prohibited to impose on high pressure;
4. Be sure the instrument wiring consistent with the internal system settings;
5. When communicating with the PC, instrument communication parameters must be consistent with the PC.



- Please read this user manual carefully
- Please save this document

Directory

1. - SUMMARIZE	- 2 -
2. - FEATURES	- 3 -
2.1. - ELECTRICITY METERING	- 3 -
2.2. - TECHNICAL PARAMETERS	- 4 -
3. - INSTALLATION AND START-UP	- 6 -
3.1. - INSTALLATION	- 6 -
3.2. - CONNECTION TERMINAL	- 9 -
3.3. - TYPICAL WIRING (3P4W)	- 10 -
4. SCREEN DISPLAY	- 11 -
4.1. - FULL SYMBOL IN DISPLAY SCREEN	- 11 -
4.2. - INTRODUCTION OF SCREEN PAGES	- 12 -
5. - OPERATION MODE	- 15 -
6. - SETUP PROCEDURE	- 16 -
6.1. - ENTER SETUP MENU	- 16 -
6.2. - INPUT SIGNAL SETUP	- 17 -
6.3. - COMMUNICATION PORT SETUP	- 18 -
6.4. - DIGITAL OUTPUT SETUP	- 20 -
6.5. - ANALOG OUTPUT SETUP	- 24 -
6.6. - SYSTEM SETTING	- 25 -
6.7. - RTC AND TOU SETUP	- 26 -
7. - PULSE OUTPUT	- 27 -
8. - COMMUNICATION INTERFACE	- 28 -
8.1. - CONNECTION FOR THE RS485 BUS	- 28 -
8.2. - MODBUS RTU PROTOCOL	- 29 -
8.3. - REGISTER MAP	- 30 -
8.3.1. - Basic power data—Primary Side	- 30 -
8.3.2. - Basic power data—Secondary Side	- 31 -
8.3.3. - Meter status data	- 32 -
8.3.4. - Multi-tariffs ratio data	- 32 -
8.3.5. - THD and Individual harmonic (Max 15 times)	- 33 -
8.3.6. - Write operation function definition: Preset Single holding register	- 33 -
8.4. - EXAMPLE	- 34 -
9. - SAFETY CONSIDERATIONS	- 35 -
10. - MAINTENANCE	- 35 -
11. - TECHNICAL SERVICE	- 36 -

1. - SUMMARIZE

APM-96Y Multi-function power meter is a Mid-range electrical panel power meter. It is the ideal choice for monitoring and measuring of 3P4W or 3P3W power systems.

It can measure all of the power parameters in power grid:

Current,	Reactive power,	Current harmonics 2~15 times,
Voltage,	Apparent power,	Voltage harmonics 2~15 times,
Frequency,	Energy (Active/Reactive),	Voltage and current THD%,
Active power,	Power factor,	Multi-tariff record(TOU)

With optional expansion modules, it can also transmit the parameter into 2*Relay output (2DO) and 4*Switch input (4DI), 1*Analog output (1AO). For transformers, generators, capacitor banks and motors of the distributed detection, automatic control system, on-line monitoring display.

It can replace the traditional analog or many digital measurement instruments (such as ammeter, voltmeter, power meter, power factor meter, frequency meter, etc.) with the advantages of improving system reliability, making the on-site wiring convenient and reduce system cost.

With serial port, APM-96Y can connect with PC; and use Modbus to set programming and read the data. Based on this power meters, you can simply set up a monitoring system with the IPC and central software. Optional RJ45 Ethernet port for MODBUS-TCP protocol.

APPLICATIONS

- All power parameter measurement;
- Energy Measurement and electrical fire monitor and control;
- Replacing the three-phase power meter, three phase electricity transmitter;
- Transformers, generators, capacitors and electric motors distributed detection;
- Medium and low voltage systems;
- SCADA, EMS, DCS integrators.

2. - FEATURES

2.1. - Electricity Metering

By means of an internal microprocessor it simultaneously measures:

Parameter	Symbol	A-phase	B-phase	C-phase	Total
Phase-line voltage	V	•	•	•	/
*Phase-phase voltage	V	•	•	•	/
Current	A	•	•	•	/
Frequency	Hz	/	/	/	•
Power factor	Cos Φ	•	•	•	•
Active power	W	•	•	•	•
Reactive power	Var	•	•	•	•
Active energy	Wh	/	/	/	•
Reactive energy	Varh	/	/	/	•
Multi-tariffs energy record	Wh	/	/	/	•
Voltage THD	—	•	•	•	/
Current THD	—	•	•	•	/
Individual harmonic (1~15 th)	—	•	•	•	•

/: No such function

•: Display and communications.

Note:

Phase-phase voltage is U_{ab} , U_{bc} , U_{ca} , voltage data determined by the different wiring.

The APM-96Y delivers the visualization of parameters listed above by means of LCD type displays.

In the main display area shows 4 power parameters, with other display area show the various parameters and state of meter on each page jump. For more details of measurement parameters please refer to the subsequent for displays introduction and RS485 communication instructions.

OTHER FEATURES

- Low-size (96 x 96 mm), panel-mounting meter.
- True R.M.S. measuring system.
- Instantaneous, maximum and minimum values of each measured parameter.
- Energy measurement (indication through a lighting led).
- RS-485 or Ethernet(optional) type communication to a PC.

2.2. – Technical parameters

- Working Power

AC/DC 90-240V, 45-65Hz

DC 20-60V (Optional)

Maximum power consumption 6W

- Input

Voltage Rated 300V L-N, (optional 100V L-N)

Current Rated 5A (optional 1A)

Frequency 45-65Hz

Current overload 1.2 times rated continuous; 1 seconds for 10 times the rated

Voltage overload 1.2 times the rated continuous; 10 seconds for 2 times the rated

- Load

Voltage: <0.1VA/ phase (rated 220V)

Current: <0.4VA/ phase (rated 5A)

- Reference Standard

Active energy IEC 62053-21:2018

Reactive energy IEC 62053-23:2018

- Accuracy

Parameter	Accuracy	A phase	B phase	C phase	All
Voltage	0.5s	V1	V2	V3	
Current	0.5s	A1	A2	A3	
Active Power	0.5s	W1	W2	W3	W
Reactive Power	1.0	var1	var2	var3	var
Apparent power	0.5	VA1	VA2	VA3	VA
Power Factor	0.5	PF1	PF2	PF3	PF
Active Energy	1.0				Wh
Reactive Energy	2.0s				varh
Frequency	0.05				Hz

- Dielectric strength

IEC / EN 61010-1:2010

2kV AC RMS 1 minute, between input / output / case / power supply

- EMC Test

Parameter	Standard	Test voltage
Discharge immunity test	IEC-61000-4-2 level 4	8kV
Fast transient burst immunity test	IEC61000-4-4 level 3	Input 1kV; Power supply 2kV
Surge (Shock) immunity test	IEC61000-4-5 level 4	Common mode :4kV

- Work environment

Temperature: -20°C ~ +60°C

Humidity: RH 20% ~ 95% (Non-condensation)

- Storage environment

Temperature: -25°C ~ +70°C

Humidity: RH 20% ~ 95%

- Protection

Panel: IP54

Case: IP20

- Dimensions

L × W × H =96mm×96mm×75mm

- Installation hole size

L × W = (91±0.8mm) × (91±0.8mm)

3.- INSTALLATION AND START-UP



The manual you hold contains information and warnings that -users should follow in order to guarantee a proper operation of all the instrument functions and keep it in safety conditions. The instrument must not be powered on and used until its definitive assembly is on the cabinet's door.

If the instrument is not used as manufacturer's specifications, the protection of the instrument will be damaged.

When any protection failure is suspected to exist (for example, it presents external visible damages), the instrument must be immediately powered off. In this case contact a qualified service representative.

3.1.- Installation

Mounting

Instrument is to be mounted on panel (cut-out $91+0.8 \times 91+0.8\text{mm}$). Keep all connections into the cabinet.

Please note that with the instrument powered on, the terminals could be dangerous to touch and cover opening actions or elements removal may allow accessing dangerous parts. Therefore, the instrument must not be used until this is completely installed.

Dimension:

Unit: mm

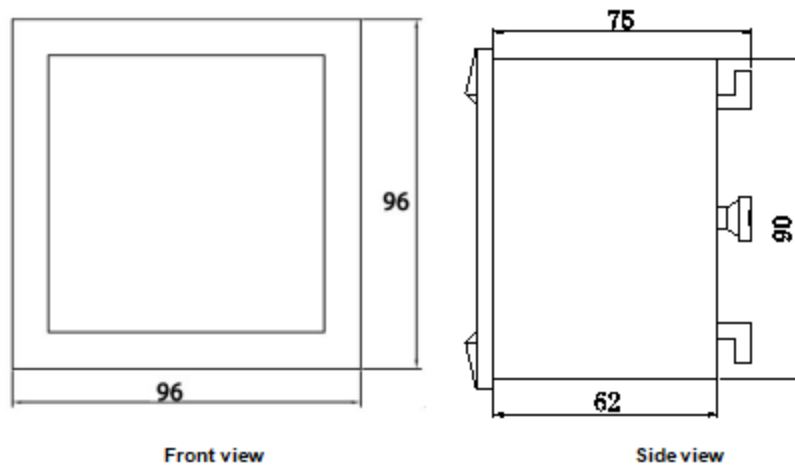

Notes:

Input signal: APM-96Y using a separate acquisition calculate for each measurement channel, to ensure consistent in use, for different load forms, it's a variety of connection mode. Access wire shall be met 2.5square mm.

A. Voltage input

Input voltage should not exceed the rated input voltage products 450V.
Otherwise, you should use external VT. Suggest 1A fuse be installed in the voltage input side.

B. Current Input

Standard input current is 5A or 1A, if greater than 5A/1A should use external CT.
When the CT is connected with other meters, make sure wiring methods be used in series.

Warning: Forbid to install a CT on the live feeder wire with open secondary leads. This can be extremely dangerous!

Before remove the current input connection, must be sure to disconnect the primary circuit or shorted secondary circuit of CT.

C. Sequence of wire

Warning: Please make sure that the input voltage and current corresponding to the same phase, sequence, and the same direction; Otherwise, the Values and symbols will be wrong! (Power and Energy)

Always observe the physical orientation of CT (P1 - P2) when installing on the feeder wire.
Always pay attention to wiring polarity and phasing when terminating the CT leads to the APM-96Y.
S1 connect to Ix*, S2 connect to Ix.

The input network configuration of instrument depends on the CT number of the system:
in the condition of 2 CT, select the three-phase, three-lines two components;
in the condition of 3 CT, select the three-phase, four-lines three component mode.

Instrument connection mode, set of the instrument (programming input network NET) should be the same load wiring as measured wiring. Otherwise, the measurement instrument will lead to incorrect voltage or power.

In three-phase 3 wire mode, measurement and shows the line voltage;
In three-phase 4 wire mode, measurement and shows the phase voltage and line voltage both.

D. Auxiliary power

APM-96Y with universal (AC / DC) power input, if not for a special statement, we provide the 90-240AC/DC power interface for standard products, please ensure that the auxiliary power can match with meter to prevent unexpected damage.

A. Suggest install 1A fuse in the fire line side.

B. For the areas with poor power quality, suggest install lightning surge suppressor and rapid burst suppressor to prevent lightning strikes.

3.2. - Connection Terminal

Upper connection terminal

15	16	50	49	48	47	60	59	58	2	1
AO-	AO+	Eq-	Eq+	Ep-	Ep+	GND	RS485B	RS485A	Power supply	

16. Analog output (+)	1. *Supply voltage input 0 V
15. Analog output (-)	2. *Supply voltage input 220 Vac.
47. Active energy (+)	58. RS-485(+)
48. Active energy (-)	59. RS-485(-)
49. Reactive energy (+)	60. RS-485(GND)
50. Reactive energy (-)	

Middle connection terminal

22	21	20	19	70	71	72	73	74
DO2		DO1		COM	DI1+	DI2+	DI3+	DI4+

20. Route 1 digital output (+)	70. Digital input COM pin
19. Route 1 digital output (-)	71. Route 1 digital input (+)
22. Route 2 digital output (+)	72. Route 2 digital input (+)
21. Route 2 digital output (-)	73. Route 3 digital input (+)
	74. Route 4 digital input (+)

Lower connection terminal

14	13	12	11	9	8	7	6	5	4
Un	Uc	Ub	Ua	C-phase Current	B-phase Current	A-phase Current			

11. Voltage A-phase input	4. Current A-phase - S1 input
12. Voltage B-phase input	5. Current A-phase - S2 input
13. Voltage C-phase input	6. Current B-phase - S1 input
14. Neutral Voltage input	7. Current B-phase - S2 input
	8. Current C-phase - S1 input
	9. Current C-phase - S2 input

Note:

The terminal pin definition may change depends on customer order; please refer to the label on the meter!

3.3. – Typical Wiring (3P4W)

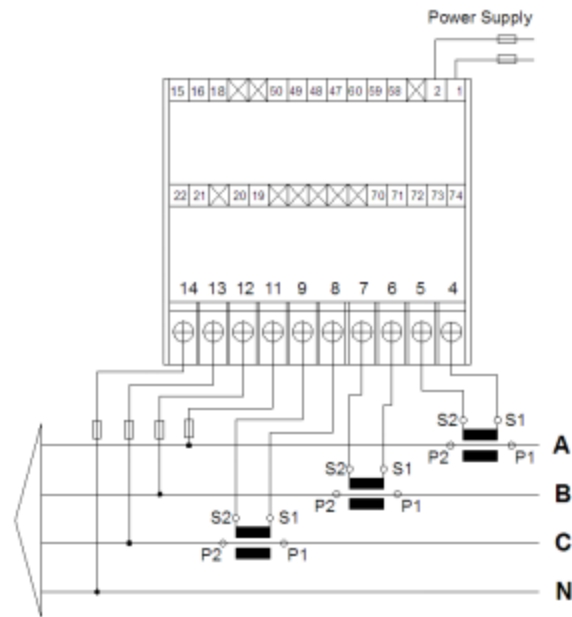

Note:

This connection drawing is for reference only; the actual connecting terminal please refer to the label on the rear part.

WARNING S!

If power = -0.01 is shown for any of the phases and voltage and current are not zero for this phase, check out following points:



- Assure that A, B and C phases coincide in voltage and current
- Correct polarity? Reverse the current transformer placed at this phase.



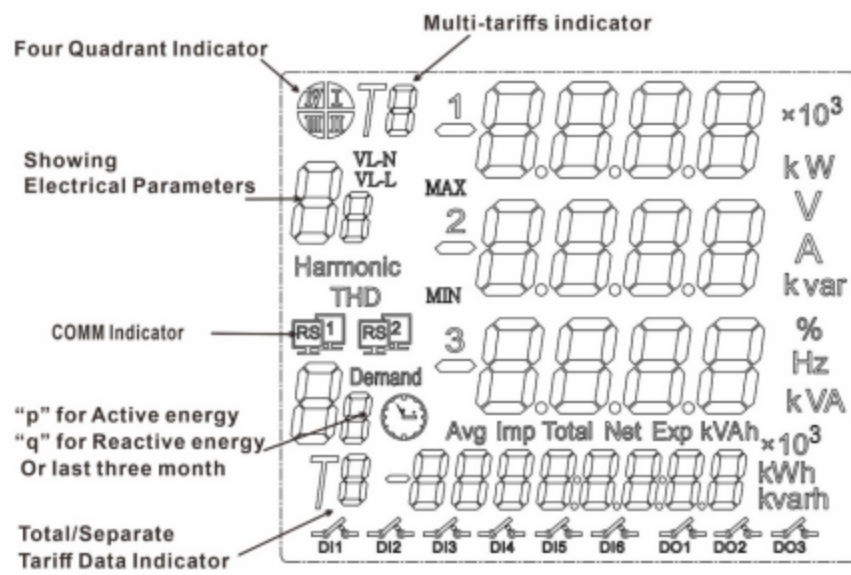



4. SCREEN DISPLAY





4.1.- Full Symbol in Display Screen



4.2.- Introduction of Screen Pages

Screen No.	Screen interface	Explanation
- 1 -		Three-phase voltage Ua, Ub, Uc; Note: In high voltage measurement, X10 ³ mean the showing value multiplied by 1000, in the screen diagram mean the voltage is 10X1,000=10,000volt. Bottom character "Ep" show total active energy is 83.6KWh.
	<p>Note: Detail information for each symbol, please refer chapter 6.1, Surround area shows the system information, in other screen are same:</p> <ul style="list-style-type: none"> show DI 1, DI2, DI3, DI4 in the closed; show DO1, DO2 opened; flickers show Communication Rx/Tx normal; 	
- 2 -		Three-phase current Ia, Ib, Ic. Bottom Ep shows total negative active energy.
- 3 -		Total active power, Total reactive power, and Total factor. Press can switch to show independent three phase power value. Bottom Eq shows total reactive energy.

- 4 -		Frequency of grid. Bottom Eq shows total negative reactive energy.
- 5 -		Multi-tariff energy record (TOU). Bottom area "E0" ~ "E3" E0: Last three months total TOU record E1: Present month TOU record E2: Last month TOU record E3: Month before last month TOU record Bottom area "T1" ~ "T4" for 4 types tariff energy sum record. Note: Press  can switch Ex/ Tx record value.
- 6 -		Real-time clock (RTC) line 1 shows year line 2 shows month line 3 shows date In the bottom line shows: Hour, Minute and Second
- 7 -		Three phase voltage Total Harmonic Distortion (THD_U%)
- 8 -		Three phase current Total Harmonic Distortion (THD_I%)

- 9 -		<p>Three phase voltage Individual Harmonic 2-15th</p> <p>Press  can switch to different harmonic</p>
- 10 -		<p>Three phase current Individual Harmonic 2-15th</p> <p>Press  can switch to different harmonic</p>





Notes:

1. Energy data is displayed in 8-digit decimal format by default. As counter increased, the decimal point position will move right, data increased by 10 times, the unit display changing from KWh to MWh.



2. In special requirement order or firmware iteration, the screen may add or reduce the screen display pages, please ask the sales team to get latest manual.

5. - OPERATION MODE

When the device is powered up, the entire symbol will be on, and the meter starts to self-test. After few seconds, the meter is ready for operation and shows firmware, then automatic jump to The first screen.

Button	In Monitor Screen	In Config Sub-menu	In Parameter Setup
	Screen will move to previous or next page	Move cursor up and down to select function	Move setting cursor to left
			Scroll selection number 0 ~ 9
	Call out password screen	Exit & roll back to up level menu.	
	Call out Sub-screen or Version screen	Confirm the values & Entry or jump to down level menu.	

Note: In Setup menu, if changed the setting value, press  for exit menu, device will call out confirm screen ask "SAVE"

Then press  *exit without saving.*
 press  *save and exit.*

6. - SETUP PROCEDURE

The SETUP procedure of the APM-96Y is performed by means of several SETUP options. There has a password to protect unexpectedly enter the Setup menu. Once into the Setup menu, use the keyboard to select different options and enter required variables:

6.1.- Enter Setup Menu

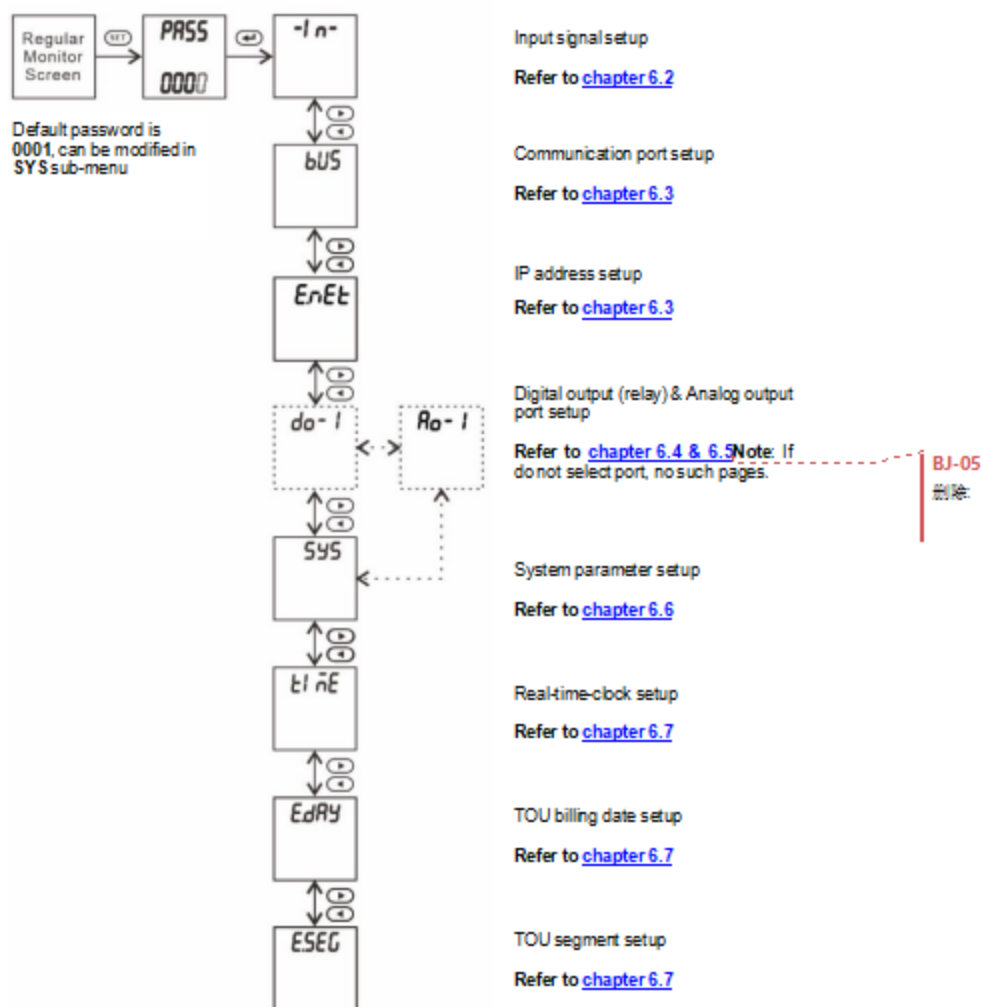

6.2. - Input Signal Setup

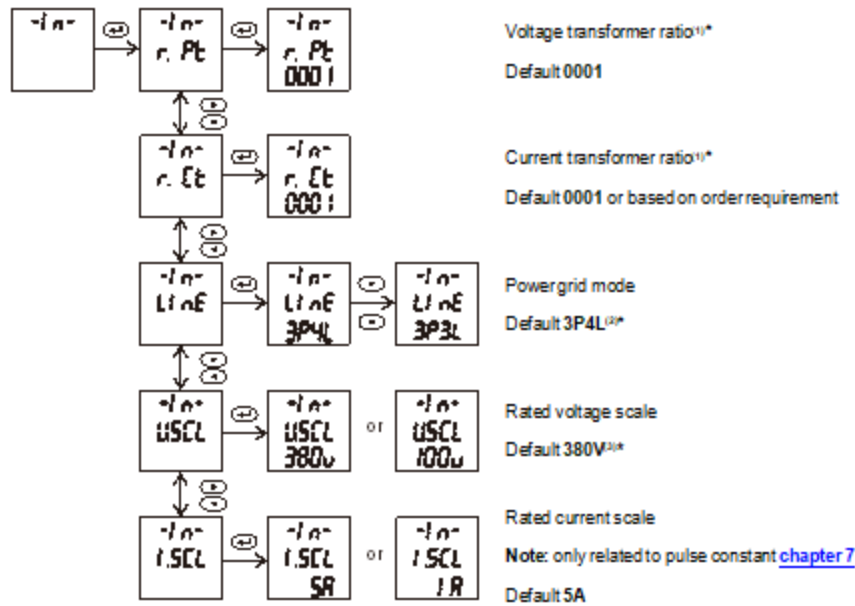

Notes:

- (1) In medium or high voltage system, set this value can expand measuring range, values represent the current transformer (primary side voltage) / (secondary side current). Must set U.scl in 100V or other specified VT secondary voltage.
- (2) If in order specified power grid are 3P3L, Blue Jay will connect Un and Ub terminal internally. In screen only show phase to phase parameter.
- (3) Blue Jay calibrate meter under 380V range, high-quality linearity performance ensures that the meter can accurately measure in the lower voltage range. That can compatible with 120V, 220V, 230V, 240V, 277V system.

If need to use in different voltage scale or different types CT, please contact our sales team for more help.

6.3. - Communication Port Setup

6.3.1.- RS485 communication port

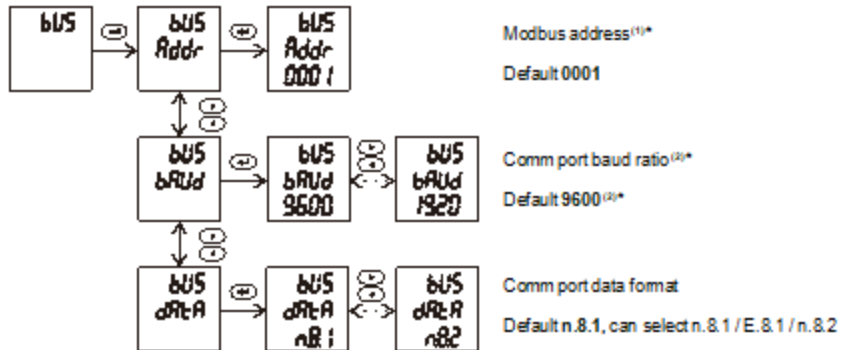

Note:

- (1) Modbus address setup range 1-247.
- (2) Baud ratio can select 1200 / 2400 / 4800/ 9600 / 19200, regular meter equipped communication port max baud ratio are 19200bps, if need higher speed, please contact Blue Jay sales team.

6.3.2.- RJ45 Ethernet port

If meter is equipped with RJ485 port, the Bus configuration is as shown below:

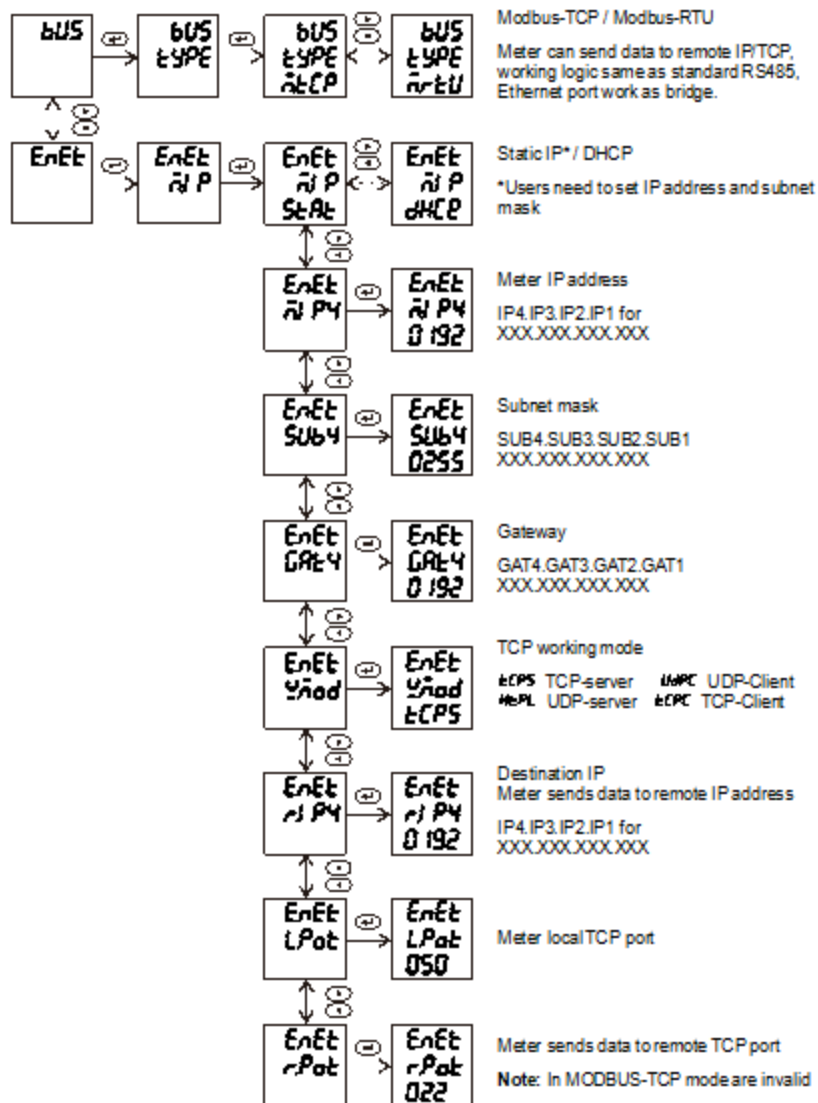

6.4. - Digital Output Setup

DO port is optional module, if do not choose this external port, in Setup menu do not have this sub-menu, and this chapter are invalid.

When device has more than one DO port, you can set the DO-2, as same step.

The physical DO relay standard is 5A 250VAC / 5A 30VDC

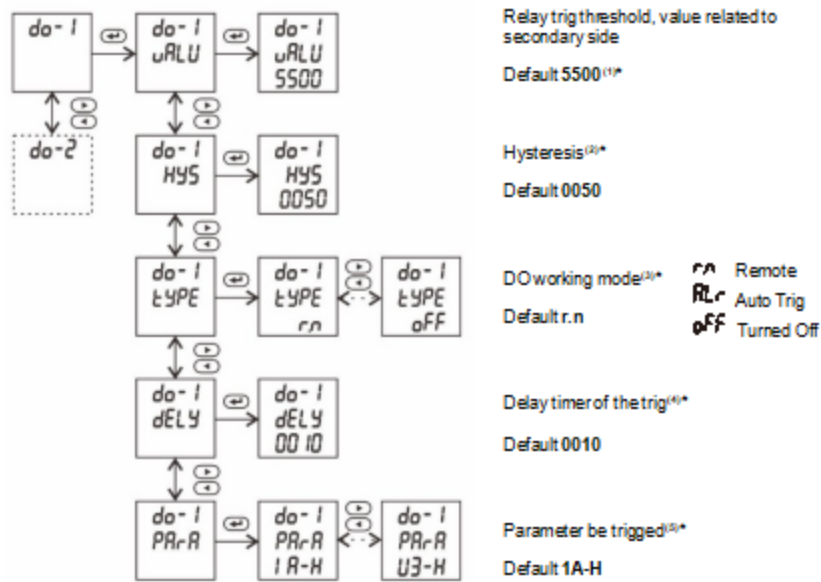

Notes:

(1) Relay trig threshold value have different units:

Voltage- 0.1V	Active power- 0.1W	Power factor- 0.001
Current - 0.001A	Reactive power- 0.1VAR	Frequency-0.01HZ

(2) Hysteresis value is for prevent unexpected relay release, only the measurement parameter falls back lower / over a certain difference value from trig threshold, the DO can be released.

Formula: $X_m < X - X_r$ (Upper edge trig) or $X_m > X + X_r$ (Lower edge trig)

$$X_r = \frac{\text{wRLU}}{\text{HYS}} \times 10000$$

X_m is measurement rms value of electrical parameter

Example: Trig threshold value 3.700A; hysteresis value 0.03; After relay triggered, when measured value $X_m < 3.589A$ ($3.700 - 3.700 \times 0.03$), the relay will be released.

(3) DO port preset 2 types of working mode, and can be Turned Off

Auto Trig – When the measurement parameter over or lower the preset wRLU the DO relay act, terminal of DO+ / DO- shorted. After the measurement parameter fall back to a certain value can be released relay coil.

Remote - DO relay act by RS-485 control command, user can use function code 05 to trig single relay, device RS-485 port follow MODBUS-RTU protocol, command as following:

Host inquiry:

Addr.	Code	No.1 Relay register	Relay value (FF00:close; 0000: open)	CRC
01	05	00 01	FF 00	DD FA

Slave response:

Addr.	Code	No.1 Relay register	Relay value (FF00:close; 0000: open)	CRC
01	05	00 01	FF 00	DD FA

(4) In **Auto trig** mode, after $X_m > \text{wRLU}$ in the specified delay time, DO relay act. Setting value from 0.000sec (no delay) to 999.9 sec, default 0010 = 1sec

In **Remote** mode, if setup value = 0, output is **Level type**.

If set value = 0, output is **Pulse type**, value = pulse width

(5) Parameter of the DO can be set, preset 52 types parameter that can be used in auto trig mode.

$Ua-H$	A phase voltage upper trig	$Qb-H$	B phase reactive power upper trig
$Ub-H$	B phase voltage upper trig	$Qc-H$	C phase reactive power upper trig
$Uc-H$	C phase voltage upper trig	$QS-H$	Total reactive power upper trig
$U3-H$	Any one of $Ua / Ub / Uc3$ upper trig	$SA-H$	A phase apparent power upper trig
$Ia-H$	A phase current upper trig	$Sb-H$	B phase apparent power upper trig
$Ib-H$	B phase current upper trig	$Sc-H$	C phase apparent power upper trig
$Ic-H$	C phase current upper trig	$SS-H$	Total apparent power upper trig
$I3-H$	Any one of $Ia / Ib / Ic3$ upper trig	$PF-H$	Total power factor upper trig
$Pa-H$	A phase active power upper trig	$F-H$	Frequency upper trig
$Pb-H$	B phase active power upper trig	$D1-H$	D1 closed trig
$Pc-H$	C phase active power upper trig	$D2-H$	D2 closed trig
$PS-H$	Total active power upper trig	$D3-H$	D3 closed trig
$QA-H$	A phase reactive power upper trig	$D4-H$	D4 closed trig

Note: If in screen show "XX -L-" mean lower limit trig, for DI port mean open loop trig.

*** Delay & Hysteresis logic**

Example in upper limit alarm of A phase voltage:

U-d mean detected Ua

U-set mean Alarm value of A phase

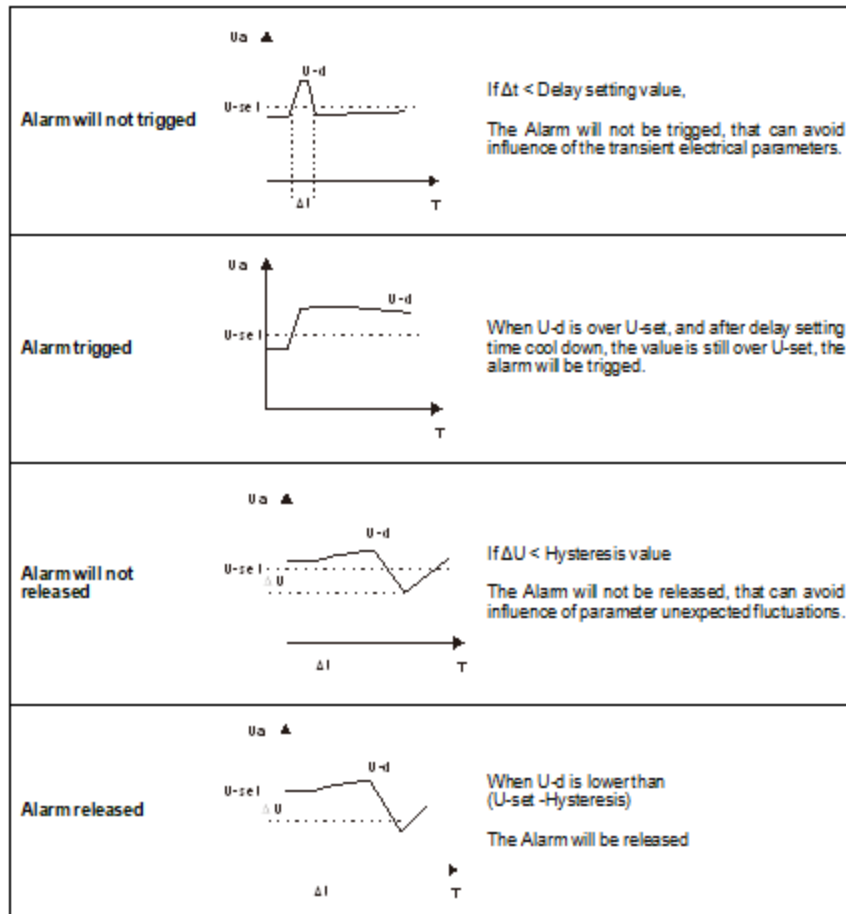

6.5. - Analog Output Setup

AO port is optional module, if do not choose this external port, in Setup menu do not have this sub-menu, and this chapter are invalid. When device has more than one AO port, you can set the AO-2..., as same step. Basic specification of AO port:

Accuracy class	0.5S
Overload	120% effective output, the maximum current of 24mA, voltage 15V
Load	$R_{max} = 420\Omega$
Isolation	1KV to other terminal (Between AO-AO port non-isolation)

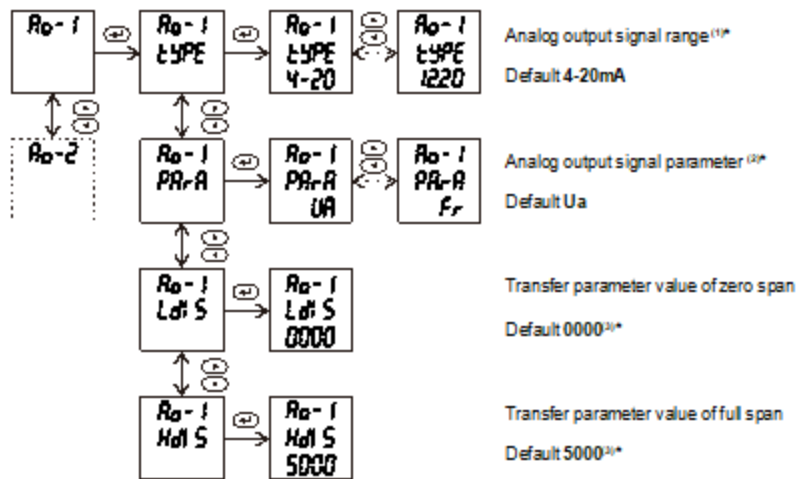

Notes:

- Signal range default are ampere output, rang 4-20mA, 12-20mA, optional voltage signal output, optional 0-5V, 10-5V, (please contact Blue Jay sales team before order).
- The analog parameter can set Ua, Ub, Uc, Uab, Ubc, Uca, Ia, Ib, Ic, Pa, Pb, Pc, PS, Qa, Qb, Qc, Qs, Sa, Sb, Sa, SS, PF, Fr.
- Transfer parameter related secondary side value (such as AC100V, AC5A), units as following.

Voltage- 0.1V	Active power- 0.1W	Power factor- 0.001
Current - 0.001A	Reactive power- 0.1VAR	Frequency-0.01HZ



Example: Setup variable: **TYPE 4-20mA** **PARA Ia** **LdS 0000** **HdS 5000**

Mean transfer A-phase current is 0.000A output 4mA, current is 5.000A output 20mA;

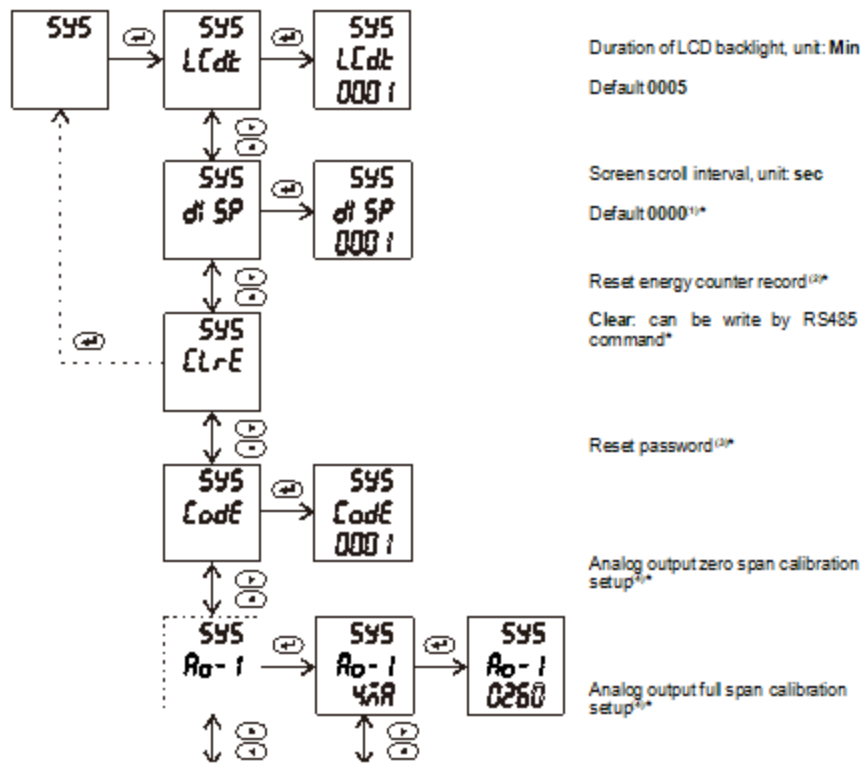
6.6. - System Setting



Notes:

- (1) Set 0000 mean manually switch each monitor screen pages.
- (2) Press  device will roll back to SYS root menu, only in the exit screen press  to trigger clear operation!!
- (3) If reset the password, please keep the password in safety, or only return to Blue Jay for reset new password!
- (4) Variable step value is 2/1000. Blue Jay already do calibration before shipping, please use high precision ammeter or voltmeter as reference standard.
- (5) Customers can write commands through RS485 or through the screen to clear the energy data to 0. Once the secondary side value of the internal memory reaches to 2^{32} (4294,967,296), counter automatically reset to 0.

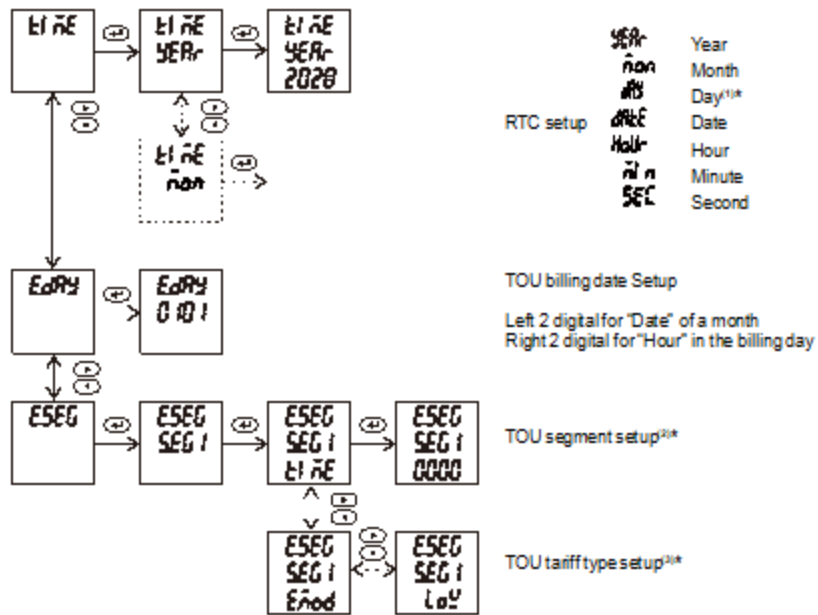
6.7. - RTC and TOU Setup

Notes:

- (1) The weekday is independent data, only loops from 1-7, and does not linked to date information, only can be read in register map and used as data identity.
- (2) APM-96Y provides last 3 months of TOU energy record. The TOU function separate one day in to 12 segments billing interval. **SEG 1** for record starting time point in one day.
- (3) Device used 4 different words to indicate 4 types tariff (T1-T4) energy consumption in different time segment and record in memory, correspondence is as follows:

Sharp	LINE	T1
Peak	PEAK	T2
Flat	FLAT	T3
Valley	Low	T4

7.- PULSE OUTPUT

APM-96Y provides 2* pulse output for the total active energy & total reactive energy.

The host / PLC / DI module can cumulative the data of both the active and reactive power energy sent by the pulse from opt coupler relay.

1). Electrical specification: voltage VCC \leq 48V, I_z \leq 50mA.

2). Pulse: 5000 imp / kWh, pulse up to 80ms.

This means: When the device detects 1 kWh, the port will generate 5000 pulse.

Note: 1 kWh energy is for secondary side energy data, if there have PT and CT accessed; primary side energy data is "1 kWh xPT ratiox CT ratio".

Voltage (V)	Current (A)	Pulse constant (imp / kWh)
380 or 220	5	5000
	1	20000
100	5	20000
	1	80000

Example: In measure time "T", the received total pulse is "N",
 Primary side input of voltage is 10Kv
 Primary side input of current is 400A.
 Secondary side measurement range is 100V and 5A.

In the time "T", energy accumulated is: $N / 20000 \times 100 \times 80$

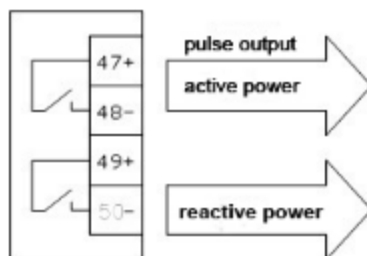

8.- COMMUNICATION INTERFACE

8.1.- Connection for the RS485 BUS

The composition of the RS-485 cabling must be carried out with a meshed screen cable (minimum 3 wire), diameter of not less than 0.5mm², with a maximum distance of 1,200 m between the APM-96Y... and the master unit. This Bus may connect a maximum of 32pcs APM-96Y...

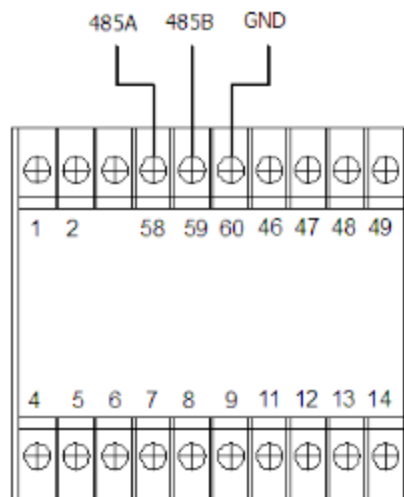

Notes:

- For communication with the master unit, user can choose RS-485 to RS-232 converter or RS485 to USB adapter to use.
- For expand the number of devices in the communication network, a signal repeater can be used.
- Full range of APM-96Y... meter RS485 PIN number is 58,59,60.
- Due to product modifications or special requirements, the interface pin place may be change.
For details, please refer to product label on the rear side.

8.2.- MODBUS © Protocol

Modbus RTU Frame Format:

Address code	1 BYTE	Slave device address 1-247
Function code	1 BYTE	Indicates the function codes like read coils / inputs
Data code	4 BYTE	Starting address, high byte Starting address, low byte Number of registers, high byte Number of registers, low byte
Error Check code	2 BYTE	Cyclical Redundancy Check (CRC)

MODBUS FUNCTIONS:

Code	Meaning	Description
FUNCTION 01	Read Coil Status	Only valid when equipped DO port
FUNCTION 02	Read Input Status	Only valid when equipped DI port
FUNCTION 03	Reading of n Words	This function permits to read all the electrical parameters of the APM-96Y.
FUNCTION 05	Force Single coil	Details see chart 6.4 When DO in remote control mode can work
FUNCTION 06	Preset Single holding register	There is an upper limit for writing, please be sure to check the upper limit of the host computer to avoid exhausting the life of the storage machine.

Note: Float data follow IEEE754, float low bit first, high bit next. (CD AB)

8.3. - Register map

8.3.1- Basic power data—Primary Side

Register	Data	Byte mode		Instruction
0x00	Ua	float	2	Phase to Line Voltage, Unit: V
0x02	Ub	float	2	
0x04	Uc	float	2	
0x06	Uab	float	2	Phase to Phase Voltage, Unit: V
0x08	Ubc	float	2	
0x0a	Uca	float	2	
0x0c	Ia	float	2	Three phase Current, Unit: A
0x0e	Ib	float	2	
0x10	Ic	float	2	
0x12	Pa	float	2	Individual phase active power, Unit: kW
0x14	Pb	float	2	
0x16	Pc	float	2	
0x18	P_{Σ}	float	2	Total active power, Unit: kW
0x1a	Qa	float	2	Individual phase reactive power, Unit: kVar
0x1c	Qb	float	2	
0x1e	Qc	float	2	
0x20	Q_{Σ}	float	2	Total reactive power, Unit: kVar
0x22	Sa	float	2	Individual phase apparent power, Unit: kVA
0x24	Sb	float	2	
0x26	Sc	float	2	
0x28	S_{Σ}	float	2	Total apparent power, Unit: kVA
0x2a	PFa	float	2	Individual phase power factor, 0~1.000
0x2c	PFb	float	2	
0x2e	PFc	float	2	
0x30	PF_{Σ}	float	2	Total power factor, 0~1.000
0x32	FR	float	2	Frequency, Unit:0.01Hz
0x34	Ep+	float	2	Positive active energy, Unit: kWh
0x36	Ep-	float	2	Negative active energy, Unit: kWh
0x38	Eq+	float	2	Inductive reactive power, Unit: kVarh
0x3a	Eq-	float	2	Capacitive reactive power

8.3.2 - Basic power data—Secondary Side

Register	Data	Byte mode		Instruction
0x100	Ua	int	1	Phase to Line Voltage, Unit: 0.1V
0x101	Ub	int	1	
0x102	Uc	int	1	
0x103	Uab	int	1	Phase to Phase Voltage, Unit: 0.1V
0x104	Ubc	int	1	
0x105	Uca	int	1	
0x106	Ia	int	1	Three phase Current, Unit: 0.001A
0x107	Ib	int	1	
0x108	Ic	int	1	
0x109	Pa	int	1	Individual phase active power, Unit: W
0x10a	Pb	int	1	
0x10b	Pc	int	1	
0x10c	$P\Sigma$	int	1	Total active power, Unit: W
0x10d	Qa	int	1	Individual phase reactive power, Unit: Var
0x10e	Qb	int	1	
0x10f	Qc	int	1	
0x110	$Q\Sigma$	int	1	Total reactive power, Unit: Var
0x111	Sa	int	1	Individual phase apparent power, Unit: kVA
0x112	Sb	int	1	
0x113	Sc	int	1	
0x114	$S\Sigma$	int	1	Total apparent power, Unit: VA
0x115	PFa	int	1	Individual phase power factor, 0~1.000
0x116	PFb	int	1	
0x117	PFc	int	1	
0x118	$PF\Sigma$	int	1	Total power factor, 0~1.000
0x119	FR	int	1	Frequency, Unit:0.01Hz
0x11a	Ep+	int	2	Positive active energy, Unit: Wh
0x11c	Ep-	int	2	Negative active energy, Unit: Wh
0x11e	Eq+	int	2	Inductive reactive power, Unit: Varh
0x120	Eq-	int	2	Capacitive reactive power

8.3.3- Meter status data

Register	Data	Byte mode		Instruction
0x200	DO	int	1	Bit 0~1 show channel 1 and channel 2 status 0 for open, 1 for closed.
0x201	DI	int	1	Bit 0~3 show channel 1 to channel 4 status 0 for open, 1 for closed.
0x20A	TOU.year	int	1	Internal RTC real time clock: Year - Month - Date - Time - Minute - Second-Day
0x20B	TOU.month	int	1	
0x20C	TOU.date	int	1	
0x20D	TOU.hour	int	1	
0x20E	TOU.minute	int	1	
0x20F	TOU.second	int	1	
0x210	TOU.day	int	1	

8.3.4- Multi- tariffs ratio data

Register	Data	Byte mode		Instruction
0x400	E0_tol	long	2	Total cumulative energy
0x402	E0_T1	long	2	T1-T4 cumulative Energy record
0x404	E0_T2	long	2	
0x406	E0_T3	long	2	
0x408	E0_T4	long	2	
0x40a	E1_tol	long	2	Total energy of present month
0x40c	E1_T1	long	2	T1-T4 Energy record of present month
0x40e	E1_T2	long	2	
0x410	E1_T3	long	2	
0x412	E1_T4	long	2	
0x414	E2_tol	long	2	Total energy of last month
0x416	E2_T1	long	2	T1-T4 Energy record of last month
0x418	E2_T2	long	2	
0x41a	E2_T3	long	2	
0x41c	E2_T4	long	2	
0x41e	E3_tol	long	2	Total energy of the month before last month
0x420	E3_T1	long	2	T1-T4 Energy record of the month before last month
0x422	E3_T2	long	2	
0x424	E3_T3	long	2	
0x426	E3_T4	long	2	

Note: In screen display the T1-T4 will display as following in screen and setup:

Sharp	LINE	T1
Peak	PEAK	T2
Flat	FLAT	T3
Valley	LOW	T4

8.3.5- THD and Individual harmonic (Max 15 times)

Register	Data	Byte mode		Instruction
0x500	THDUa	int	1	A-phase Voltage THD, unit 0.1%
0x501	THDUb	int	1	B-phase Voltage THD
0x502	THDUc	int	1	C-phase Voltage THD
0x503	THDia	int	1	A-phase Current THD, unit 0.1%
0x504	THDib	int	1	B-phase Current THD
0x505	THDic	int	1	C-phase Current THD
0x508-0x545	HUa	int	32	Each phase voltage individual Harmonic 2~15 th , unit 0.1%
0x548-0x586	HUb	int	32	
0x588-0x5C5	HUc	int	32	
0x5C8-0x605	Hla	int	32	Each phase current individual Harmonic 2~15 th , unit 0.1%
0x608-0x645	Hlb	int	32	
0x648-0x685	Hlc	int	32	

8.3.6 - Write operation function definition: Preset Single holding register

Register	Data	Byte mode		Instruction
0x900	Line	int	1	Wiring method: 0: 3-phase 4-wire 1: 3-phase 3-wire 2CT 2: 3-phase 3-wire 3CT
0x901	U.SCL	int	1	Voltage range 0:100V 1:380V
0x902	I.SCL	int	1	Current range 0:1A 1:5A
0x903	PT	int	1	Voltage ratio
0x904	CT	int	1	Current ratio

Notes:

1. Not all of the data above can be read by RS485, the reading address will be unsuccessful.
2. The data can be read out depends on your multi-function meter model, please refer to the corresponding product manual before build your software.
3. Some software has different definitions of the start bit of register address, there will be offset, please add 1 for the right address. To get more info, please contact technical support tech@cqbluejay.com

8.4.- Example

Host inquiry slave device

Addr.	Func.	Data Address (high)	Data Address (low)	Data Number (high)	Data number (low)	CRC16 (low)	CRC16 (high)
0CH	03H	00H	00H	00H	06H	C4H	D5H

PC user ask upload UA, UB, UC, IA, IB, IC

Slave device response

Addr.	Func.	Byte count	Data1 high	Data1 low	Data2 high	Data2 low	Data3 high	Data3 low
0CH	03H	0CH	03H	E8H	03H	E9H	03H	E8H
Data4 high	Data4 low	Data5 high	Data5 low	Data6 high	Data6 low	CRC16 low	CRC16 high	
13H	84H	13H	88H	13H	8AH	A6H	D6H	

Show the data:

UA=3E8H (100.0)

UB=3E9H (100.1)

UC=3E7H (99.9)

IA=1384H (4.996)

IB=1388H (5.000)

IC=138AH (5.002)

Notes:

- Blue Jay disable the 06 function in default setting, if Activated the write command, please check the host device program to avoid the meaningless write operation, that may reduce the reduce the register working life.
- When the write is unsuccessful, no return data from the slave device. In this addition, please re-send write inquiry again.

9. - SAFETY CONSIDERATIONS



All installation specification described at the previous chapters named:
INSTALLATION AND STARTUP, INSTALLATION MODES and SPECIFICATIONS.

Please note that with the instrument powered on, the terminals could be dangerous to touching and cover opening actions or elements removal may allow accessing dangerous parts. This instrument is factory-shipped at proper operation condition.

- ◆ The device must have a professional installation and maintenance.
- ◆ Any operation of the device, you must cut off the input signal and power.

10. - MAINTENANCE

The APM-96Y meter does not require any special maintenance. No adjustment, maintenance or repairing action should be done when the instrument is open and powered on, should those actions are essential, high-qualified operators must perform them.

Before any adjustment, replacement, maintenance or repairing operation is carried out, the instrument must be disconnected from any power supply source.

When any protection failure is suspected to exist, the instrument must be immediately put out of service. The instrument's design allows a quick replacement in case of any failure.

11. - TECHNICAL SERVICE

FAQ's

- 1.- Once cabled and connected is seen to give a correct voltage and current reading, but shows negative values for active power (generation).

This is an error with the cabling for the current transformer secondary; the direction of the transformer current has to be respected as shown in the connection diagram. The current transformers have a two face primary; the current must pass from P1 to P2 giving the result in secondary (S1 and S2) of 5 amps.

The error stems from:

- a). The current transformers have been incorrectly installed. As a result, it gives the direction of the current as passing from P2 to P1; to resolve this problem, the current transformer does not have to be dismantled and installed again, but the transformer secondary (S1 and S2) just has to be inverted.
- b). The connection of the current secondary in the current transformers have been incorrectly connected; to resolve this problem just connect the S1 transformer secondary to the S1 on the meter and the S2 on the current transformer to the S2 on the meter

- 2.- Once cabled and connected, is seen to give an incoherent Power factor and $\text{Cos}\Phi$ reading (-0.01 or similar).

This is again a current transformer and voltage phase connection error phase A, must correspond to the current transformer installed in phase A; phase B, must correspond to the current transformer installed in phase B; and phase C, must correspond to the current transformer installed in phase C.

This connection terminal is clearly shown on the area side of the device.

- 3.- The measuring voltage and is displaying the secondary voltage (for example 110 volts). Ensure that the voltage Transformer ratio has been correctly set (Please refer to voltage PT ratio setting section in chapter **SETUP PROCEDURE**).
- 4.- Device does not correctly display the current reading. It shows values varying between 0 to 5 amps of current. Ensure that the Current Transformer ratio has been correctly set; (Please refer to current CT ratio setting section in chapter **SETUP PROCEDURE**).

Calculation formula of electrical parameter

Formula	Parameter
$U = \sqrt{\frac{1}{N} \sum_{n=0}^N u_n^2} \quad n = 0, 1, 2, \dots, N$	Voltage RMS value
$I = \sqrt{\frac{1}{N} \sum_{n=0}^N i_n^2} \quad n = 0, 1, 2, \dots, N$	Current RMS value
$P = \frac{1}{N} \sum_{n=1}^N (i_{an} u_{an} + i_{bn} u_{bn} + i_{cn} u_{cn})$	Total active power cycle average
$P_s = UI$	Single-phase apparent power cycle average
$\cos \theta = \frac{P_p}{P_s}$	Powerfactor
$P_q = \sqrt{P_s^2 - P_p^2}$	Reactive power (Pq is positive and the direction cannot be determined; P algorithm can be used to shift the voltage component by 90°)
$W = \int P * dt$	Electric energy

Note: In above formula, N for sampling points in one AC wave, In standard APM-96Y, the N=128

For any inquiry about the instrument performance or any failure, contact to Blue Jay's technical service.

Blue Jay - After-sales service

E-mail: tech@cqbluejay.com

Tel: +0086-023-67628702

www.cqbluejay.com

Add: 1802, Building

2, No. 88, Jianxin

East

Road, Chongqing, 400020, China

-38-

Email: tech@cqbluejay.com