

# GYDCG-UBC1 Series

## (Small Model, Single DC Channel)

### User Manual

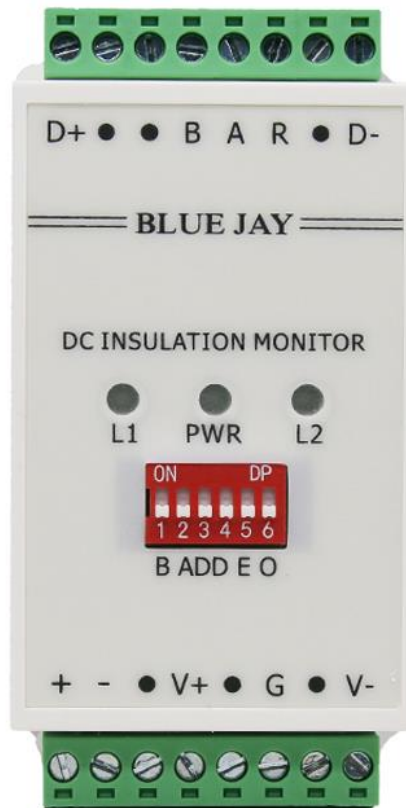

**Version: 1.14**

**Revision 2023.12**

## Read me

**When you use GYDCG-UBC1 Series, be sure to read this user manual carefully, and be able to fully understand the implications, the correct guidance of operations in accordance with user manual, which will help you make better use of GYDCG-UBC1 Series, and help to solve the various problems at the scene.**

1. Before turning on the power supply, be sure that the power supply within the provisions of the instrument;
2. When installation, the current input terminal must non-open, voltage input terminals must Non-short circuit;
3. Communication terminal (RS485) is strictly prohibited to impose on high pressure;
4. Be sure the instrument wiring consistent with the internal system settings;
5. When communicating with the PC, instrument communication parameters must be consistent with the PC.



- **Please read this user manual carefully**
- **Please save this document**

## Directory

<b>1. - SUMMARIZE .....</b>	<b>- 3 -</b>
<b>2. - TECHNICAL PARAMETERS .....</b>	<b>- 4 -</b>
<b>3. - INSTALLATION.....</b>	<b>- 5 -</b>
3.1. - MOUNTING.....	- 5 -
3.2. - CONNECTION TERMINAL.....	- 6 -
3.3.- THE LED DISPLAY .....	- 7 -
<b>4. - COMMUNICATION INTERFACE .....</b>	<b>- 8 -</b>
4.1. - CONNECTION FOR RS485 .....	- 8 -
4.2. - COMMUNICATION PROTOCOL.....	- 9 -
<b>5. - MODEL SELECTION SHEET .....</b>	<b>- 15 -</b>
<b>6. - SAFETY CONSIDERATIONS .....</b>	<b>- 16 -</b>
<b>7. - MAINTENANCE .....</b>	<b>- 16 -</b>
<b>8. - FAQs .....</b>	<b>- 17 -</b>

## 1. - SUMMARIZE

The GYDCG-UBC1 Series model product is an efficient insulation monitoring device designed for car charging piles. It can monitor the insulation condition of the DC power system of the car charging pile in real time, detect and alarm any potential insulation failure in time, so as to effectively prevent the occurrence of fire and safety accidents. Users can realize the start and stop of a certain insulation monitoring and the acquisition of values through RS485 communication.

This product has the characteristics of high reliability, easy installation, and convenient use. It is one of the important equipment to ensure the safe and stable operation of car charging piles. In addition, the monitor can also provide effective information about the charging pile power system through data analysis and processing, and provide an important reference for operation management and maintenance.

The product can send communication frames through RS485 to turn on or off the insulation monitoring function. After the insulation monitoring function is turned on, the high-voltage grounding switch K is closed and the real-time measurement of insulation resistance is realized. After the insulation monitoring function is turned off, the high-voltage grounding switch K is disconnected. The host can send read command to read the insulation resistance value of positive and negative poles at any time.

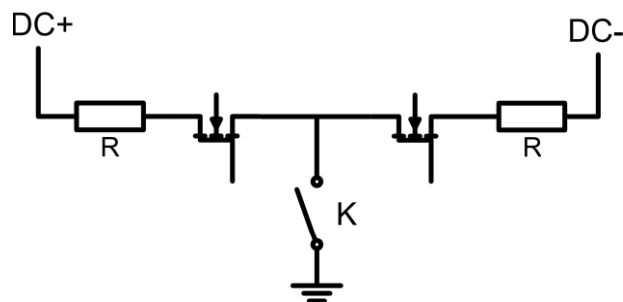

### FEATURES

- Remote monitoring and management
- Monitor positive and negative poles
- Ground insulation resistance
- DC voltage monitoring
- Vehicle side DC voltage monitoring
- Voltage reverse polarity alarm

### APPLICATIONS

- DC capacitor discharge
- Guarantee the safety and stability of charging
- Improvement of the efficiency and charging quality
- Personnel and equipment security

## 2. - TECHNICAL PARAMETERS

### Basic parameters

Parameter	Value
Power supply	9~30VDC, power 4W
DC voltage range	100V~1000V
Vehicle side voltage measurement range	100V~1000V
DC voltage at pile side accuracy	≤2V+0.3%
Insulation monitoring accuracy	DC voltage 100V~300V: ≤3KΩ+10% DC voltage 300V~1000V: ≤3KΩ+5% C <sub>γ</sub> >0.3μF, Insulation resistance >1MΩ: >10%
Insulation resistance measurement range	1KΩ~10 MΩ (DC System voltage:100V~1000V)
Off-line pressure test	<2mA
Standard	IEC 61851-23 (2014-03):2014-11
Humidity	85%
Storage temperature	- 40°C ~125°C
Operating temperature	- 40°C ~70°C

### Other parameters

Pressure point	Maximum voltage rating	Time
D+/D- TO GND	3000VDC/2500VAC	≤1min
Power supply +/- TO GND	3500VDC/3000VAC	≤1min
RS485 A/B TO GND	3000VDC/2500VAC	≤1min
V+/V- TO GND	3000VDC/2500VAC	≤1min

### 3. - INSTALLATION

#### 3.1. - Mounting

The module can be installed by guide rail or screw fixation. Guide rail using standard width 35mm. External dimensions are shown as follows: (Unit: mm)

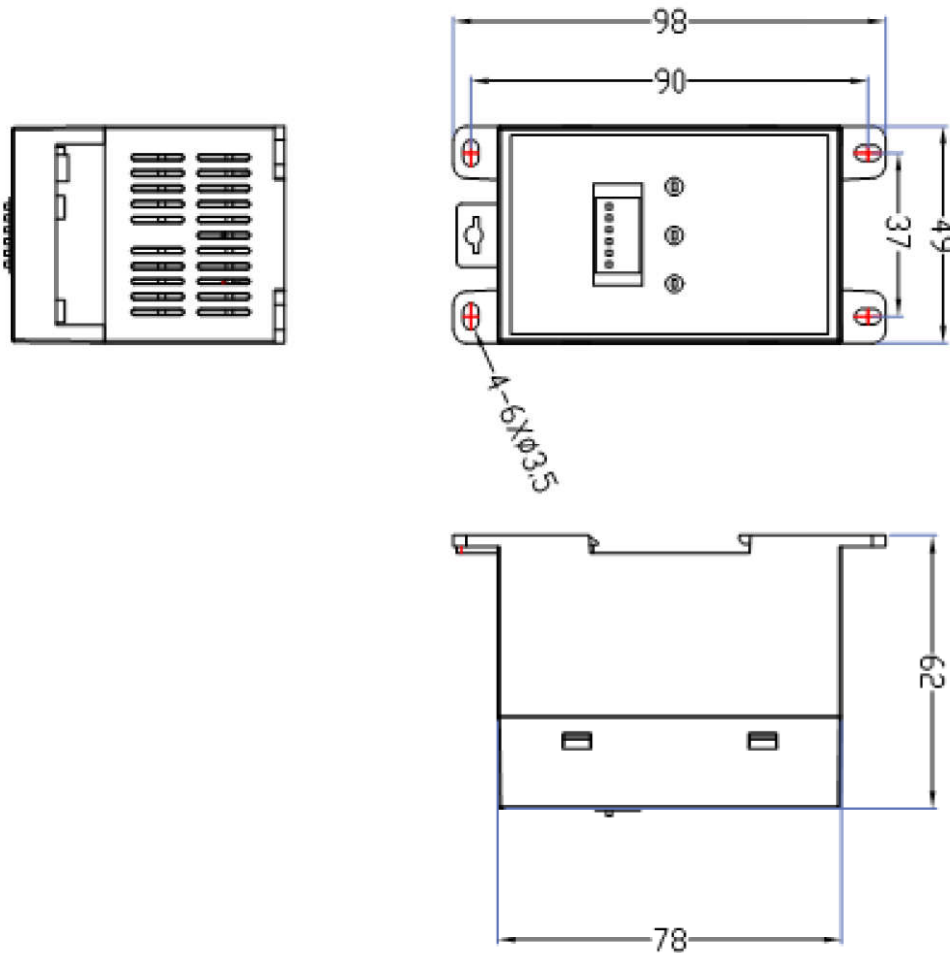

### 3.2. - Connection Terminal

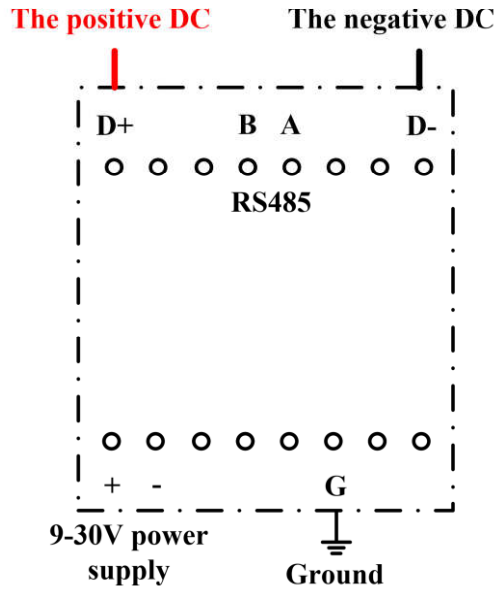

Interface	Connection mode	Definition
D+	Positive pole of DC	DC interface
D-	Negative pole of DC	
A	RS485-A	
B	RS485-B	
+	Positive pole of power supply	9-30VDC
-	Negative pole of power supply	
GND	Grounding point	
V+	Positive pole of vehicle side voltage	Use only for UBC1SMV/ UBC1MVX
V-	Negative pole of vehicle side voltage	
R	External discharge resistance	Use only for UBC1X/ UBC1MVX

**Notes:**

1. Modules without discharge function need not be connected with external discharge resistance;
2. Without vehicle side voltage measurement, there is no need to connect the DC voltage V+ and V- on the vehicle side.

Details refer to [Chapter 5](#).

### **3.3.- The LED display**

After the module is powered on, the PWR indicator is on. When the insulation monitoring is power on, the “L1” light is on, and when the insulation monitoring is power off, the “L1” light is off.



## 4. - COMMUNICATION INTERFACE

### 4.1. - Connection for RS485

In RS485 communication system, this IMD module works in slave mode. Baud rate, communication address, parity check mode, can be set by DIP switch, default stop bit 1, data bit 8. The interval between each byte in the sent frame must not exceed 20ms, otherwise the frame will be cleared.

#### Communication Parameter configuration bit

Dip switch 1 bit is used to set the baud rate, 2 to 4 bits are used to set the communication address, and 5,6 bits are used to set the parity check. The setting mode is shown below.

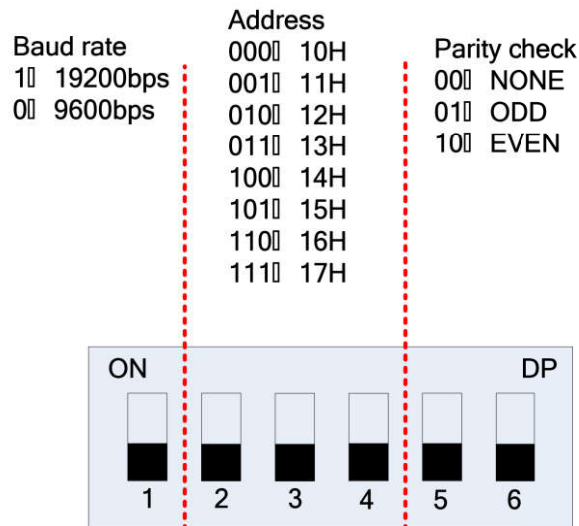

## 4.2. - Communication Protocol

GYDCG-UBC1 series adopts custom Modbus protocol. Except for sending address command is variable. CRC is obtained according to the actual calculation, register data are defined and unchanged. Described as following:

### 4.2.1 - Write operation function definition (FunctionX02): Writes a single register (No slave response)

**Definition 1** Enable insulation monitoring function (ground relay is closed)

**Host inquiry:**

Addr. 02 00 02 10 20 CRC CRC

**(No slave response)**

**Definition 2** Turn off insulation monitoring function (ground relay is disconnected)

**Host inquiry:**

Addr. 02 00 02 10 00 CRC CRC

**(No slave response)**

**Definition 3** Open discharge (for products with discharge function, the discharge will be automatically closed)

**Host inquiry:**

Addr. 02 00 02 10 0C CRC CRC

**(No slave response)**

**Command example:**

**1. Enable the insulation monitoring function**

**Host inquiry:**

10 02 00 02 10 20 D6 93

**(No slave response)**

**2. Turn off insulation monitoring function**

**Host inquiry:**

10 02 00 02 10 00 D7 4B

**(No slave response)**

#### 4.2.2 - Read data definition (Functionx01)

**Definition 1** Read DC voltage, positive and negative insulation resistance

**Host inquiry:**

Addr. 01 02 03 04 05 CRC CRC

**Slave response:**

02(H): Status word height bytes (Correspondence Address)

02(L): Status word low bytes

03(H): Dc voltage high bytes

03(L): Dc voltage low byte

04(H): Positive insulation resistance high bytes

04(L): Positive insulation resistance low bytes

05(H): Negative insulation resistance high bytes

05(L): Negative insulation resistance low bytes

CRC: According to actual calculation

CRC: According to actual calculation

**Notes:**

Only when the DC voltage is between 100V~1000V, Insulation resistance monitoring can be realized. If DC voltage is low than 100V, or it is turned on within a short time, the insulation resistance read is 0xFFFF (means invalid number).

If the read insulation resistance value is a valid number, the insulation resistance value monitoring range is between 1KΩ~10MΩ. When the measured value is greater than 10MΩ, the value received by the communication is 0xEA60 (means infinity).

**Command example:****Host inquiry:**

10 01 02 03 04 05 0C 30

**Slave response:**

10 30 01 F4 EA 60 00 32 74 D3

## Definitions:

- 02H: Data=0X1030, indicate: the mailing address is 10H;  
Bit4 =1 indicates that the module is working and can be queried.
- 03H: Data=0X01F4=500, indicate: the DC voltage is 500V.
- 04H: Data=0XEA60=60000, indicate: the positive insulation resistance is infinite.
- 05H: Data=0X0032=50, indicate: the negative insulation resistance value 50KΩ

**Definition 2     Read vehicle side voltage****Host inquiry:**

Addr.01 02 FF 08 09 CRC CRC

**Slave response:**

02(H): Status word height bytes (Correspondence Address)

02(L): Status word low bytes

00(H): FF

00(L): FF

08(H): Vehicle side voltage high byte

08(L): Pile side voltage high byte

09(H): 00

09(L): 00

CRC: According to actual calculation

CRC: According to actual calculation

**Command example:****Host inquiry:**

10 01 02 FF 08 09 C9 05

**Slave response:**

10 30 FF FF 01 90 00 00 70 CE

## Definitions:

02H: Data=0X1030, indicate: the mailing address is 10H;  
Bit4 =1 indicates that the insulation monitoring of the module is complete and can be read.

08H Data=0X0190=400, indication: the DC voltage on the side of the vehicle is 400V.

#### 4.2.3 - 02H Indicates the meaning of the status word

<b>Bit0</b>	Vehicle side DC voltage reverse connection fault detection (reverse voltage above 30V) <b>0= no reverse connection; 1 = reverse connection</b>
<b>Bit1</b>	Pile side DC voltage reverse connection fault detection (reverse voltage above 180V) <b>0= no reverse connection; 1 = reverse connection</b>
<b>Bit2</b>	NC
<b>Bit3</b>	NC
<b>Bit4</b>	Insulation monitoring result status query <b>0= insulation monitoring resistance value is invalid, and the insulation resistance value read at this time is meaningless;</b> <b>1= The insulation monitoring resistance value is effective and can be read</b>
<b>Bit5</b>	Insulation monitoring grounding relay status query <b>0= The ground switch is disconnected; insulation monitoring does not work;</b> <b>1= Ground switch closed, insulation monitoring is working.</b>
<b>Bit6</b>	NC
<b>Bit7</b>	NC
<b>Bit8~ Bit15</b>	Correspondence address

## 5. - MODEL SELECTION SHEET

DC Insulation Monitor (Small Model, Single Channel)	
GYDCG-UBC1	Single-circuit insulation monitoring DC voltage detection
GYDCG-UBC1SMV	Single-circuit insulation monitoring DC voltage detection vehicle side voltage measurement
GYDCG-UBC1X	Single-circuit insulation monitoring DC voltage detection DC capacitor discharge
GYDCG-UBC1MVX	Single-circuit insulation monitoring DC voltage detection vehicle side voltage measurement DC capacitor discharge

**Notes:**

**1. Vehicle side voltage measurement ( Optional, with 'V' in the model sheet)**

The measurement range is 0V~1000V, and the output value is the actual voltage value. Connect the positive and negative poles of the vehicle side DC to "V+" and "V-" to measure the vehicle side DC voltage in real time.

**2. DC capacitor charge discharge (Optional, with 'X' in the model sheet)**

For models equipped with a discharge function, discharge is achieved by sending a discharge command message. The discharge circuit controls the discharge function by turning on and off the IGBT, and the discharge current should be less than 20A. The discharge function will automatically turn off after 2 seconds of being activated.



## 6. - SAFETY CONSIDERATIONS



All installation specification described at the previous chapters named:  
**INSTALLATION AND STARTUP, INSTALLATION MODES and SPECIFICATIONS.**

Please note that with the instrument powered on, the terminals could be dangerous to touching and cover opening actions or elements removal may allow accessing dangerous parts. This instrument is factory-shipped at proper operation condition.

- ◆ The device must have a professional installation and maintenance
- ◆ Any operation of the device, you must cut off the input signal and power;

## 7. - MAINTENANCE

The GYDCG-UBC1 Series does not require any special maintenance. No adjustment, maintenance or repairing action should be done when the instrument is open and powered on, should those actions are essential, high-qualified operators must perform them.

Before any adjustment, replacement, maintenance or repairing operation is carried out, the instrument must be disconnected from any power supply source.

When any protection failure is suspected to exist, the instrument must be immediately put out of service. The instrument's design allows a quick replacement in case of any failure.

## 8. - FAQs

**Question 1: The power indicator LED is off**

Check whether the power supply terminal of the module is improperly connected, or the hot swap overcurrent causes the fuse to burn, try to avoid hot plug.

**Question 2: The insulation monitoring resistance is infinite after the simulation of insulation resistance**

Check whether the ground cable is connected reliably at GND port.

**Question 3: The insulation monitoring resistance is much smaller than actual value**

The DC ground capacitance may be too large. Check the DC ground capacitance

For any inquiry about the instrument performance or any failure, contact to Blue Jay's technical service.

*Blue Jay - After-sales service*

E-mail: [tech@cqbluejay.com](mailto:tech@cqbluejay.com)