

GYDCG-UBCH2-LZ

DC Insulation Monitor Device

(Dual Channels)

User Manual



Version:1.15

Revision 2023.12

Read me

When you use GYDCG-UBCH2-LZ, be sure to read this user manual carefully, and be able to fully understand the implications, the correct guidance of operations in accordance with user manual, which will help you make better use of GYDCG-UBCH2-LZ, and help to solve the various problems at the scene.

1. Before turning on the power supply, be sure that the power supply within the provisions of the instrument;
2. When installation, the current input terminal must non-open, voltage input terminals must Non-short circuit;
3. Communication terminal (RS485) is strictly prohibited to impose on high pressure;
4. Be sure the instrument wiring consistent with the internal system settings;
5. When communicating with the PC, instrument communication parameters must be consistent with the PC.



- **Please read this user manual carefully**
- **Please save this document**

Directory

1. - SUMMARIZE	- 3 -
2. - TECHNICAL PARAMETERS	- 5 -
3. - INSTALLATION.....	- 7 -
3.1. - MOUNTING.....	- 7 -
3.2. - CONNECTION TERMINAL.....	- 8 -
4. - COMMUNICATION INTERFACE.....	- 10 -
4.1. - CONNECTION FOR RS485.....	- 10 -
4.2. - MODBUS © PROTOCOL.....	- 11 -
5 - REGISTER MAP.....	- 12 -
6. - SAFETY CONSIDERATIONS	- 16 -
7. - MAINTENANCE	- 16 -
8. - FAQs	- 17 -

1. - SUMMARIZE

GYDCG-UBCH2-LZ is based on MODBUS protocol of DC insulation monitoring device, is used in on-line monitoring insulation resistance of the DC floating system (two DC system shared one ground). two DC channels are controlled independently, two DC insulation monitoring non-interference in each other. Users can enable or disable the insulation monitoring function of each DC channel and acquire insulation resistance values by RS485 communication.

The IMD can measure the insulation resistance value in the DC system of 100~1000V, the resistance ranges of 1KΩ~10MΩ, read unit by KΩ. When the insulation resistance value is greater than 10 MΩ, the insulation resistance data read value is 60000 (0xEA60), indicating infinity. If the read insulation resistance data is 65535 (0xFFFF), means the data is invalid. The invalid data (0xFFFF) indicates that the insulation monitoring function is not fully started, or is in the closed state, or the DC voltage is less than 100V.

This IMD adopts dual-DC channels independent control scheme. Its schematic diagram is shown in the following figure. Users can control dual-channel startup, shutdown and data reading respectively according to the content of communication protocol. Take DC1 channel as an example. When the insulation monitoring function is disable, the positive and negative extreme relays K1 and K2 are disconnected, and the DC voltage and insulation resistance monitoring will not be provided at this time. When the host computer of the user sends the DC1 open instruction to IMD, K1 and K2 relays are closing, and the DC1 voltage is collected and insulation resistance is calculated immediately. The user can read the corresponding DC1 voltage and insulation resistance value. The application and principle of DC2 is same to DC1. Dual independent control. When the two insulation monitoring functions are closed, the K5 relay is disconnected and the IMD disconnects from the ground.

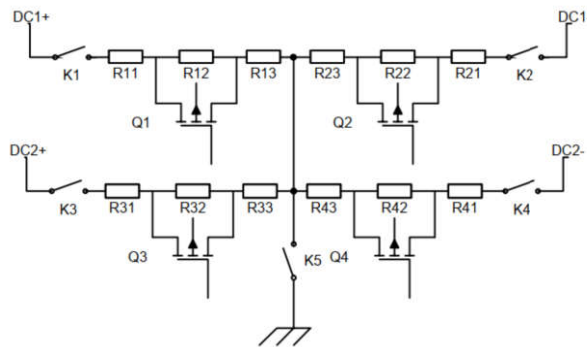

Figure 1 Schematic diagram of double DC- channels insulation monitoring principle

FEATURES

- Two independent control
- Remote monitoring and management
- Monitor positive and negative poles
- Ground insulation resistance
- DC voltage monitoring
- Vehicle side DC voltage monitoring
- Voltage reverse polarity alarm

APPLICATIONS

- Guarantee the safety and stability of charging
- Improvement of the efficiency and charging quality
- Personnel and equipment security
- Electric vehicle safety testing

2. - TECHNICAL PARAMETERS

Basic parameters

Parameter	Value
Power supply	9-30VDC, Power 6W
DC voltage range	100V~1000V
DC voltage measurement accuracy	≤2V+0.3%
Insulation resistance measurement range	1KΩ~10 MΩ (DC System voltage:100V~1000V)
	C_Y range Resistance range Accuracy
Insulation monitoring accuracy (When :DC voltage:100V-1000V)	0~0.8μF ≤60kΩ ≤3kΩ
	0.8μF ~3μF 60kΩ<R≤1MΩ ≤5%
	0.8μF ~3μF ≤60kΩ ≤6kΩ
	0.8μF ~3μF 60kΩ<R≤1MΩ ≤20%
Off-line pressure test	<2mA
Standard	IEC 61851-23 (2014-03):2014-11
Humidity	85%
Storage temperature	- 40°C ~125°C
Operating temperature	- 40°C ~75°C

Notes:

1.When facing the ground insulation resistance R_{ISO+} and negative insulation resistance to ground R_{ISO-} , The difference is too large, Multiplier of difference>10 times, R_{ISO+} and R_{ISO-} Large resistors may not be typical values.

2.C_Y Refers to the positive and negative Y capacitance values of the system bus to ground.

Other parameters

Pressure point	Maximum voltage rating	Time
DC+/DC- To GND	4200VDC/3000VAC	≤1min
Power supply +/- To GND	4200VDC/3000VAC	≤1min
RS485 A/B To GND	4200VDC/3000VAC	≤1min
DC+/DC- To Power supply +/-	4200VDC/3000VAC	≤1min
DC+/DC- TO A/B	4200VDC/3000VAC	≤1min

3. - INSTALLATION

3.1. - Mounting

The module can be installed by guide rail or screw fixation. Guide rail using standard width 35mm. External dimensions are shown as follows: (Unit: mm)

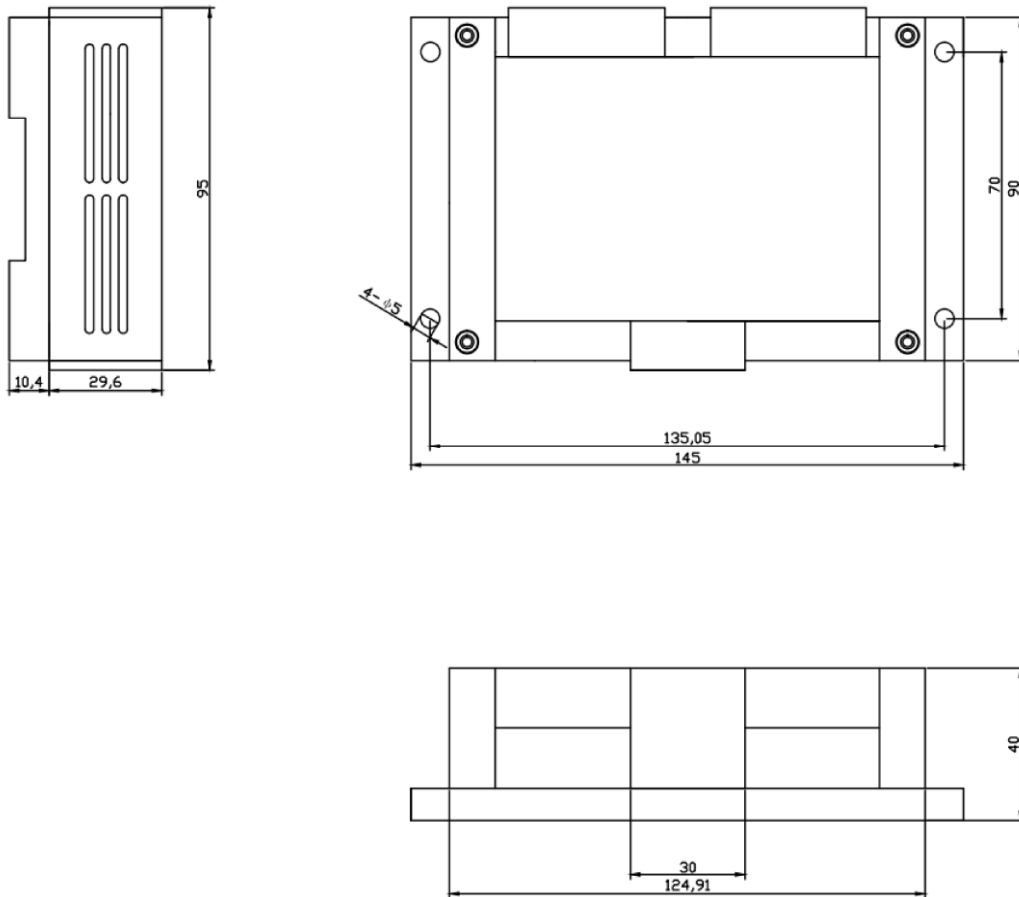

3.2. - Connection Terminal

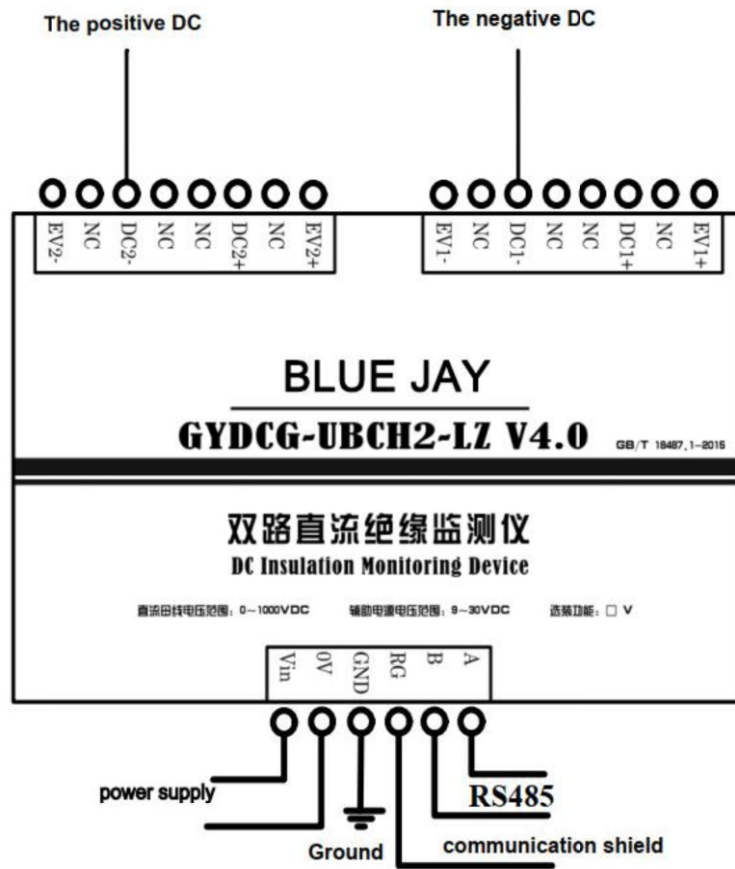

Interface	Connection mode	Definition
DC1+	Positive pole of DC 1	DC1 interface 1
DC1-	Negative pole of DC 1	
DC2+	Positive pole of DC 2	DC2 interface 2
DC2-	Negative pole of DC 2	
Vin	Positive pole of power supply	9-30VDC
0V	Negative pole of power supply	
GND	Grounding point	
RG	485 Communication Ground port (can leave it unwired)	Reserved , communication shielded line access point
A	485A	
B	485B	

4. - COMMUNICATION INTERFACE

4.1. - Connection for RS485

In RS485 communication system, this IMD module works in slave mode. Baud rate, communication address, parity check mode, can be set by DIP switch, default stop bit 1, data bit 8. The interval between each byte in the sent frame must not exceed 20ms, otherwise the frame will be cleared.

4.1.1 - Communication Parameter configuration bit

Two Dip switch configuration bit 'CONFIG', one of which can be used to configure the communication verification mode. E stands for EVEN parity and O stands for ODD parity. Touse the corresponding check sum, simply dial the corresponding position to "ON". If E and O are set to no, indicates NONE parity. See Figure 2.

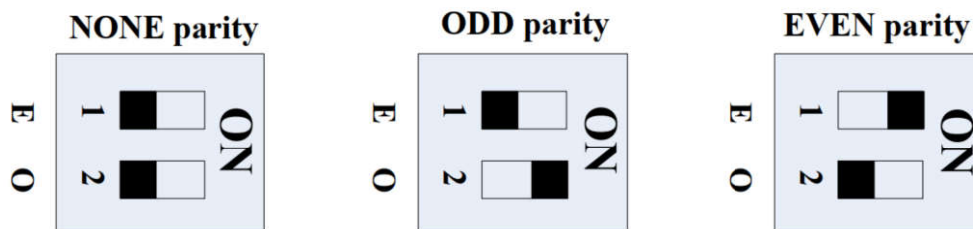

Figure 2 Configuration of communication verification mode

4.1.2 - Initializing Module Communication Parameters

Dip switch configuration bit 'CONFIG', second function can be used to initialize communication parameters. When E and O of CONFIG are dialed to ON at the same time foat least 3 seconds, the baud rate is restored to 9600bps and the communication address is restored to 01H and 02H. The system can be initialized only once after each power on. Thetotal number of times for modifying the baud rate, changing the communication address, andinitializing the baud rate must be less than 1 million. See Figure 3

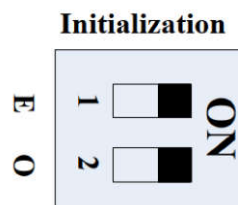

Figure 3 Initial configuration of communication parameters

4.2. - MODBUS © Protocol

The device provides the Modbus RTU protocol interface and uses the Modbus RTU 0x03/0x06 command. The default device addresses are 0x01 and 0x02. Baud rate The default baud rate is 9600 bps. The data bit is 8 and the stop bit is 1. The IMD works in slave mode and supports 9600bps and 19200bps baud rates.

4.2.1 - Modbus RTU Frame Format:

Address code	1 BYTE	Slave device address 1-247
Function code	1 BYTE	Indicates the function codes like read coils / inputs
Data code	4 BYTE	Starting address, high byte Starting address, low byte Length of registers, high byte Length of registers, low byte
Error Check code	2 BYTE	Cyclical Redundancy Check (CRC)

MODBUS FUNCTIONS:

Code	Meaning	Description
FUNCTION 01	Read Coil Status	Only valid when equipped DO port
FUNCTION 02	Read Input Status	Only valid when equipped DI port
FUNCTION 03	Read holding register	This function permits to read all the electrical parameters
FUNCTION 05	Write Single coil	When DO in remote control mode can work
FUNCTION 06	Write single register	This function permits to write a value into a single holding register.

5 - Register map

Register	Data	Byte format		Instruction
0x0010	Bus voltage	float		Unit:0.1V,voltage between positive and negative poles of DC bus
0x0012	DC1 Positive insulation resistance DC2 Positive insulation resistance	float	1	The unit is KΩ, an integer
0x0013	DC1 Negative insulation Resistance DC2 Negative insulation Resistance	float	1	The unit is KΩ, an integer
0x001A	Read version number	float	1	
0x001B	IO state	float	1	Bit1: Whether the current insulation resistance monitoring results are valid. Bit2: Whether the insulation monitoring is on and the high voltage switch is closed. Bit7: Bus voltage back connection alarm (when the back connection voltage is above 170V, this position 1)
0x0102	Insulation monitoring control	float	1	Enable DC1 insulation monitoring. Enable DC2 insulation monitoring.
	Insulation monitoring control			Disable DC1 insulation monitoring. Disable DC2 insulation monitoring.
0x0103	Modify the address	float	1	Change the address from 01H to 02H; Change the address from 02H to 03H; (Turn the 2-bit DIP switch to the ON position after power-on to modify it)
0x0104	Modify the baud rate	float	1	Change the baud rate to 9600; Change baud rate to 19200 (Turn the 2-bit DIP switch to the ON position after power-on to modify it)

0x66	The host broadcast reads the slave address	float	1	Example of reply from machine FF 66 01 02 50 7E The slave addresses are 0x01 and 0x02
------	--	-------	---	---

Notes:

Only when the DC voltage is between 100V~1000V, Insulation resistance monitoring can be realized. If DC voltage is low than 100V, or it is turned on within a short time, the insulation resistance read is 0xFFFF (means invalid number).

If the read insulation resistance value is a valid number, the insulation resistance value monitoring range is between 1KΩ~10MΩ. When the measured value is greater than 10MΩ, the value received by the communication is 0xEA60 (means infinity).

Command samples:

Sample1 Start insulation monitoring

Host inquiry:

01 06 01 02 00 11 E9 FA

Slave response:

01 06 02 00 11 78 84

Sample2 Turn off insulation monitoring

Host inquiry:

01 06 01 02 00 00 29 F6

Slave response:

01 06 02 00 00 B8 88

Sample3 Read the DC bus voltage and positive and negative electrode resistance to the ground (read 4 registers)

Host inquiry:

01 03 00 10 00 04 45 CC

Slave response:

01 03 08 03 E8 02 58 EA 60 02 58 A9 7F

Definition: Read the DC voltage 0X03E8(100V), the total insulation resistance 0X0258(600KΩ), the positive insulation resistance 0xEA60 (infinite), the negative insulation resistance 0X0258 (600KΩ).

Sample4 Read IO status:

Host inquiry:

01 03 00 1B 00 01 F4 0D

Slave response:

01 03 02 00 84 B8 27

Definition: Bus voltage reverse connection, insulation monitoring is enabled (ground relay is closed), insulation resistance monitoring is invalid.

Slave response:

01 03 02 00 06 38 46

Definition: There is no reverse connection of bus voltage, insulation monitoring is enabled (ground relay is closed), and insulation resistance monitoring is effective.

Sample5 Read version number

Host inquiry:

01 03 00 1A 00 01 A5 CD

Slave response:

01 03 02 22 01 61 24

Definition: The version number is V2201.

6. - SAFETY CONSIDERATIONS



All installation specification described at the previous chapters named:
INSTALLATION AND STARTUP, INSTALLATION MODES and SPECIFICATIONS.

Please note that with the instrument powered on, the terminals could be dangerous to touching and cover opening actions or elements removal may allow accessing dangerous parts. This instrument is factory-shipped at proper operation condition.

- ◆ The device must have a professional installation and maintenance
- ◆ Any operation of the device, you must cut off the input signal and power;

7. - MAINTENANCE

The GYDCG-UBCH2-LZ does not require any special maintenance. No adjustment, maintenance or repairing action should be done when the instrument is open and powered on, should those actions are essential, high-qualified operators must perform them.

Before any adjustment, replacement, maintenance or repairing operation is carried out, the instrument must be disconnected from any power supply source.

When any protection failure is suspected to exist, the instrument must be immediately put out of service. The instrument's design allows a quick replacement in case of any failure.

8. - FAQs

Question 1: The power indicator LED is off

Check whether the power supply terminal of the module is improperly connected, or the hot swap overcurrent causes the fuse to burn, try to avoid hot plug.

Question 2: Communication failure

Do not use USB-232-485 bipolar interface for communication, If the communication fails again, use the CONFIG mode to restore the factory Settings parameters. ([chapter4.1.2](#))

Question 3: The insulation monitoring resistance is infinite after the simulation of insulation resistance

Check whether the ground cable is connected reliably at GND port.

Question 4: The insulation monitoring resistance is much smaller than actual value

The DC ground capacitance may be too large. Check the DC ground capacitance

Question 5: Communication initialization is invalid

The system can be initialized only once by CONFIG during each power-on.

For any inquiry about the instrument performance or any failure, contact to Blue Jay's technical service.

Blue Jay - After-sales service

E-mail: tech@cqbluejay.com