

# GYDCG-UBCW2K-Series

## DC Insulation Monitor User Manual



Version: 1.0

Revision 2023.12

## Read me

**When you use GYDCG-UBCW2K- Series, be sure to read this user manual carefully, and be able to fully understand the implications, the correct guidance of operations in accordance with user manual, which will help you make better use of GYDCG-UBCW2K- Series, and help to solve the various problems at the scene.**

1. Before turning on the power supply, be sure that the power supply within the provisions of the instrument;
2. When installation, the current input terminal must non-open, voltage input terminals must Non-short circuit;
3. Communication terminal (RS485) is strictly prohibited to impose on high pressure;
4. Be sure the instrument wiring consistent with the internal system settings;
5. When communicating with the PC, instrument communication parameters must be consistent with the PC.



- **Please read this user manual carefully**
- **Please save this document**

## Directory

<b>1. - SUMMARIZE .....</b>	<b>- 3 -</b>
1.1 - THE LED DISPLAY .....	- 5 -
1.2.- DIP SWITCH CONFIGURATION BIT .....	- 5 -
1.3.- INSULATION RESISTANCE ALARM THRESHOLD SETTING .....	- 6 -
1.4.-RELAY OUTPUT .....	- 6 -
<b>2. - TECHNICAL PARAMETERS .....</b>	<b>- 7 -</b>
<b>3. - INSTALLATION AND STAR UP.....</b>	<b>- 8 -</b>
3.1. - MOUNTING.....	- 8 -
3.2. - WIRING METHOD .....	- 9 -
<b>4. - COMMUNICATION INTERFACE .....</b>	<b>- 10 -</b>
4.1. - CONNECTION FOR RS485 .....	- 10 -
4.2. - COMMUNICATION PROTOCOL .....	- 10 -
4.3 - COMMAND SAMPLES .....	- 11 -
<b>5. - MODEL SELECTION SHEET .....</b>	<b>- 14 -</b>
<b>6. - SAFETY CONSIDERATIONS .....</b>	<b>- 14 -</b>
<b>7. - MAINTENANCE .....</b>	<b>- 15 -</b>

## 1. - SUMMARIZE

GYDCG-UBCW2K series is a DC-to-ground insulation monitoring module based on the principle of unbalanced bridge, which has monitoring and protection functions in one. It can monitor the insulation resistance value of the positive and negative poles of the DC floating system to the ground, ranging from  $1\text{K}\Omega$  to  $10\text{M}\Omega$ ; at the same time, it can also detect the DC voltage value, ranging from  $100\text{V}$  to  $2000\text{V}$ .

The insulation resistance monitoring can only be realized when the DC voltage is between  $100\text{V}$  and  $2000\text{V}$ . When the DC voltage is less than  $100\text{V}$ , or the insulation monitoring is not enabled, the insulation resistance read is 65535 (invalid number). When the measured value is greater than  $10\text{M}\Omega$ , the value received by the communication is 60000 (infinity).

After the insulation monitoring function is turned on, the product continues to monitor the insulation resistance in real time, and the user can read the insulation resistance value as soon as 1 second after the insulation monitoring function is turned on. For the presence of DC-to-ground capacitance, the module can realize self-adaptive monitoring of the ground capacitance below  $3\mu\text{F}$  (the positive and negative poles to the ground capacitance are respectively below  $3\mu\text{F}$ , and the total capacitance is below  $6\mu\text{F}$ ). When there is a ground-to-ground capacitance, the monitoring time is the longest No more than 2.5s.

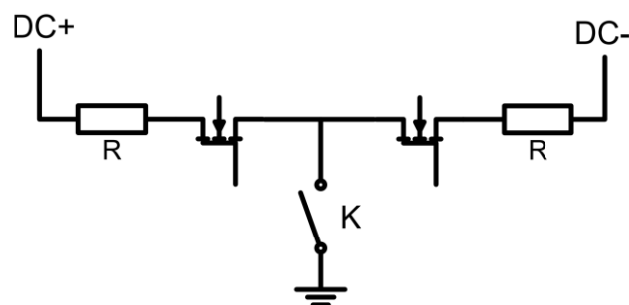

## FEATURES

- High voltage grounding switch
- Widely power supply range
- Widely insulation monitoring range ( $100\text{V}\sim 2000\text{VDC}$ )
- insulation monitoring equipment self-test
- Adaptive capacitance to ground
- Convenient parameter setting
- Remote monitoring and management
- Monitor positive and negative poles
- Ground insulation resistance
- Voltage reverse polarity alarm

## APPLICATIONS

- Insulation resistance monitoring
- DC voltage monitoring
- Guarantee the safety and stability of charging
- Improvement of the efficiency and charging quality
- Personnel and equipment security

### 1.1 - The LED display

After the module is powered on, the PWR indicator is on.

When the insulation monitoring is power on, the “L1” light is on, and when the insulation monitoring is power off, the “L1” light is off.

When the insulation resistance is less than the alarm threshold, the 'LD2' light is on; otherwise, the 'LD2' light is off.

### 1.2.- DIP switch configuration bit

When the corresponding dial is turned to the "ON" direction, it is set to "1".

The 4-bit DIP switch of CONFIG1, the first bit sets the baud rate, 9600bps or 19200bps; the 2~4 bits set the communication address.

The 6-bit DIP switch of CONFIG2 is used to set the insulation resistance alarm threshold.

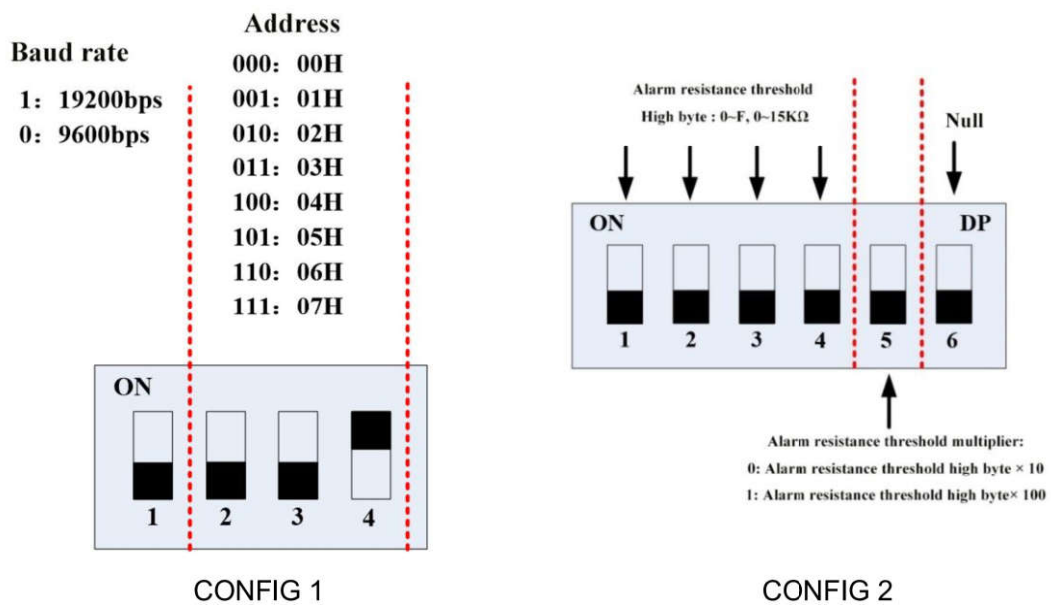

### 1.3.- Insulation resistance alarm threshold setting

The insulation resistance alarm threshold can be set through the 1-5 digits of the CONFIG2 dial switch, among which the 1-4 digits are the set value, and the fifth digit is the setting magnification. If the setting value is 15 and the magnification is 10, the set alarm is only 150KΩ.

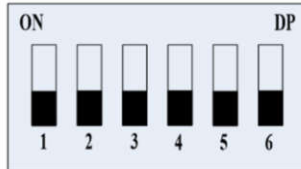

Alarm resistance value is communication setting value

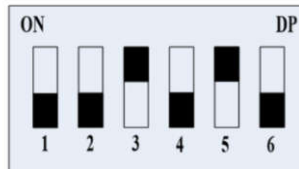

Alarm resistance threshold is 200KΩ

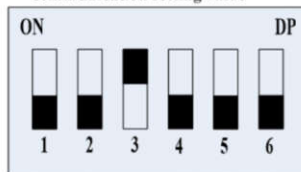

Alarm resistance threshold is 20KΩ

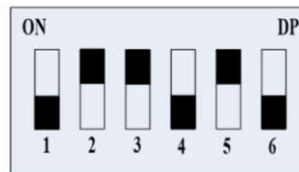

Alarm resistance threshold is 600KΩ

### 1.4.- Relay output

When the insulation resistance is lower than the set threshold, the alarm relay output terminals, namely 'DO+' and 'DO-' terminals are closed. Users can connect the DO+ terminal and DO- terminal in series with the electrical system to realize the protection function. The series current should be less than 3A, and the open circuit voltage should be less than 250VAC/30VDC.

## 2. - TECHNICAL PARAMETERS

### Basic parameters

Parameter	Value	
Power supply	9-30VDC, Power 3W	
DC voltage range	100V~2000V	
DC voltage measurement accuracy	≤2V+0.3%	
Insulation resistance measurement range	1KΩ~10 MΩ (DC System voltage:100V~2000V)	
Insulation monitoring accuracy	DC voltage:100V-300V	≤3kΩ+10%
	DC voltage:300V-2000V	≤3kΩ+5%
	CY>0.3μF, insulation resistance>1MΩ or CY>1μF	>10%
Off-line pressure test	<2mA	
Maximum relay switching voltage	250VAC/30VDC	
Maximum relay switching current	3A	
Relay contact resistance	<100mΩ	
Relay insulation resistance	100MΩ	
Standard	IEC 61851-23 (2014-03):2014-11	
Humidity	85%	
Storage temperature	- 40°C ~125°C	
Operating temperature	- 40°C ~75°C	

#### Notes:

1.When facing the ground insulation resistance  $R_{ISO+}$  and negative insulation resistance to ground  $R_{ISO-}$ , The difference is too large, Multiplier of difference>5 times,  $R_{ISO+}$  and  $R_{ISO-}$  Large resistors may not be typical values.

2. $C_Y$  Refers to the positive and negative Y capacitance values of the system bus to ground respectively.



### 3. - INSTALLATION AND STAR UP

#### 3.1. - Mounting

GYDCG-UBCW2K module can be installed by rail or screw. Guide rails use standard width of 35mm. Overall dimensions are shown below: (Unit: mm)

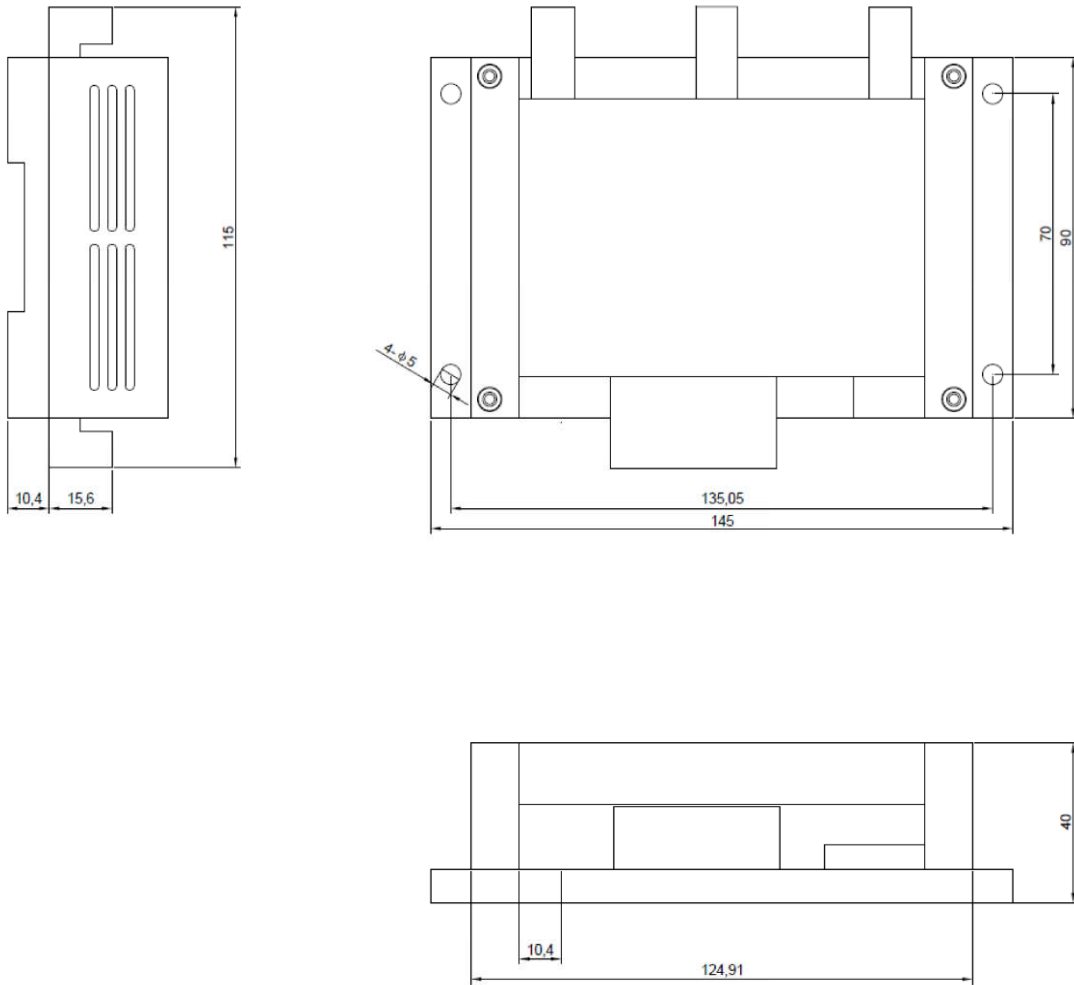

### 3.2. - Wiring Method

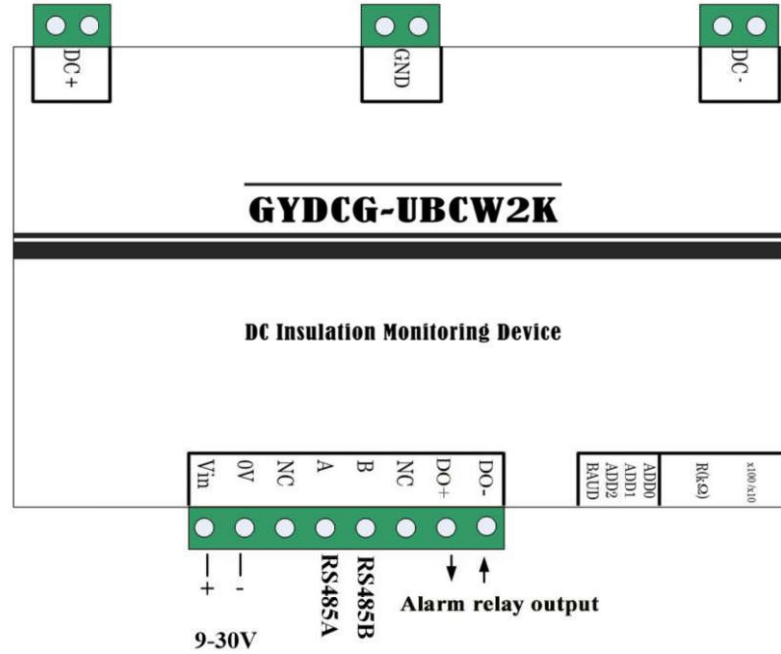

Interface	Connection mode	Definition
DC+	Positive pole of DC	DC interface 1
DC-	Negative pole of DC	
Vin	Positive pole of power supply	10-30Vdc
0V	Negative pole of power supply	
A	RS485-A	
B	RS485-B	
GND	Grounding point	
DO+	Alarm relay output	
DO-	Alarm relay output	

## 4. - COMMUNICATION INTERFACE

### 4.1. - Connection for RS485

Users can send and receive data frames through the RS485 communication port, and the circuit is equipped with a 120Ω terminal resistor. The specific operation method can be found in the "RS485 communication protocol". Terminals A and B correspond to A and B output by RS485 respectively.

### 4.2. - Communication Protocol

GYDCG-UBCW2K provides Modbus RTU protocol interface, using Modbus RTU 0x03/0x06 command; baud rate, communication address, can be set by dial switch, stop bit 1, data bit 8. The time interval between each byte in the sending frame must not exceed 20ms, otherwise the frame will be cleared.

This module works in slave mode.

#### Modbus RTU Frame Format:

<b>Address code</b>	<b>1 BYTE</b>	<i>Slave device address <b>1-247</b></i>
<b>Function code</b>	<b>1 BYTE</b>	<i>Indicates the function codes like read coils / inputs</i>
<b>Data code</b>	<b>4 BYTE</b>	<i>Starting address, high byte Starting address, low byte Length of registers, high byte Length of registers, low byte</i>
<b>Error Check code</b>	<b>2 BYTE</b>	<i>Cyclical Redundancy Check ( <b>CRC</b> )</i>

**MODBUS FUNCTIONS:**

Code	Meaning	Description
<b>FUNCTION 03</b>	Read hold register	<i>This function permits to read all the electrical parameters</i>
<b>FUNCTION 06</b>	Write single register	<i>This function permits to write a value into a single holding register.</i>

**4.3 - Command samples**

**4.3.1 - Read Command (Function x 03)**

**Sample 1**      Read the DC bus voltage and positive and negative insulation resistance to the ground(read 4 registers)

**Host inquiry:**

01 03 00 10 00 04 45 CC

**Slave response:**

01 03 08 00 00 02 58 EA 60 02 58 81 64

**Notes:**

Read the DC voltage 0X0000(0V),  
 The total insulation resistance 0X0258 (600KΩ),  
 The positive insulation resistance 0XEA60 (infinite),  
 The negative insulation resistance 0X0258 (600KΩ).

**Notes:**

Only when the DC voltage is between 100V~1000V, Insulation resistance monitoring can be realized. If DC voltage is low than 100V, or it is turned on within a short time, the insulation resistance read is 0xFFFF (means invalid number).

If the read insulation resistance value is a valid number, the insulation resistance value monitoring range is between 1KΩ~10MΩ. When the measured value is greater than 10MΩ, the value received by the communication is 0xEA60 (means infinity).

**Sample 2**      Read IO status

**Host inquiry:**

01 03 00 1B 00 01 F4 0D

**Slave response:**

01 03 02 00 06 38 46

Means that: the insulation monitoring is starting (the grounding relay is closed), and the insulation resistance monitoring is valid.

#### 4.3.2 -Write Command (Function x 06)

**Sample 1**      Turn on insulation monitoring:

**Host inquiry:**

01 06 01 02 00 11 E9 FA

**Slave response:**

01 06 02 00 11 78 84

**Sample 2**      Turn off insulation monitoring:

**Host inquiry:**

01 06 01 02 00 00 29 F6

**Slave response:**

01 06 02 00 00 B8 88

### 4.3.3 - Register Map

Register	Data	Instruction
0x0010	DC bus voltage	Unit V, voltage between positive and negative busbars, multiplier 0.1
0x0012	Insulation resistance of DC+ to Ground	Unit K $\Omega$ , Take an integer
0x0013	Insulation resistance of DC- to Ground	Unit K $\Omega$ , Take an integer
0x001B	IO Status	<p>Bit1: Whether the insulation resistance monitoring function is effective. (1-effective, 0-ineffective).</p> <p>Bit2: Whether the insulation monitoring is turn on and the ground switch is closed. (1- on, 0- off).</p>
0x0102	Insulation monitoring control	Turn on insulation monitoring function
	Insulation monitoring control	Turn off insulation monitoring function
0x0103	Insulation monitoring control	Turn on self-test function
		Turn off self-test function

## 5. - MODEL SELECTION SHEET

GYDCG-UBCW2K Series	
GYDCG-UBCW2K-RSA	Alarm dry contact output + RS485 communication
GYDCG-UBCW2K-RS	RS485 communication
GYDCG-UBCW2K-A	Relay alarm output

## 6. - SAFETY CONSIDERATIONS



All installation specification described at the previous chapters named: **INSTALLATION AND STARTUP, INSTALLATION MODES and SPECIFICATIONS.**

Please note that with the instrument powered on, the terminals could be dangerous to touching and cover opening actions or elements removal may allow accessing dangerous parts. This instrument is factory-shipped at proper operation condition.

- ◆ The device must have a professional installation and maintenance
- ◆ Any operation of the device, you must cut off the input signal and power;

## 7. - MAINTENANCE

The GYDCG-UBCW2K Series does not require any special maintenance. No adjustment, maintenance or repairing action should be done when the instrument is open and powered on, should those actions are essential, high-qualified operators must perform them.

Before any adjustment, replacement, maintenance or repairing operation is carried out, the instrument must be disconnected from any power supply source.

When any protection failure is suspected to exist, the instrument must be immediately put out of service. The instrument's design allows a quick replacement in case of any failure.

For any inquiry about the instrument performance or any failure, contact to Blue Jay's technical service.

*Blue Jay - After-sales service*

E-mail: [tech@cqbluejay.com](mailto:tech@cqbluejay.com)