

GYDCG-UBCH2

DC Insulation Monitor Device

(Dual Channels, Private Protocol)

User Manual

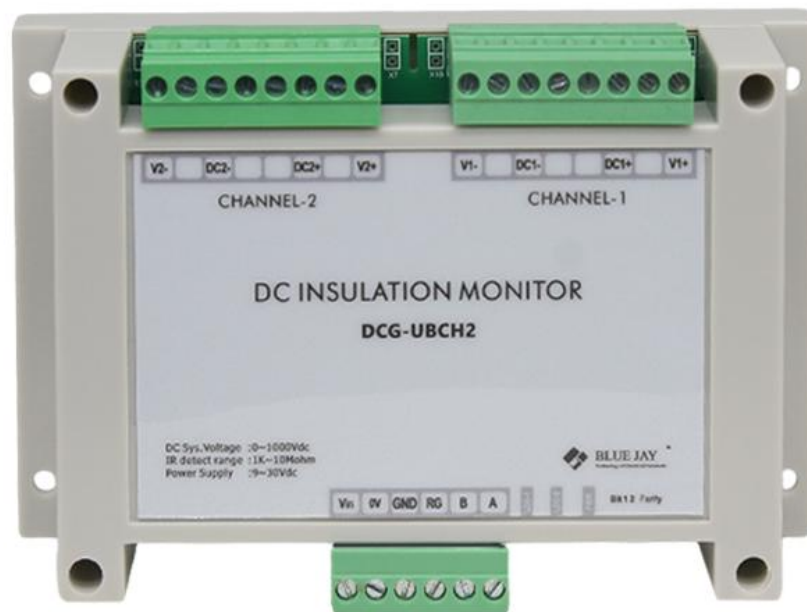

Version: 1.12

Revision: 2024.7

Read me

When you use GYDCG-UBCH2 DC insulation monitor device, be sure to read this user manual carefully, and be able to fully understand the implications, the correct guidance of operations in accordance with user manual, which will help you make better use of GYDCG-UBCH2, and help to solve the various problems at the scene.

1. Before turning on the power supply, be sure that the power supply within the provisions of the instrument;
2. When installation, the current input terminal must non-open, voltage input terminals must Non-short circuit;
3. Communication terminal (RS485) is strictly prohibited to impose on high pressure;
4. Be sure the instrument wiring consistent with the internal system settings;
5. When communicating with the PC, instrument communication parameters must be consistent with the PC.



- **Please read this user manual carefully**
- **Please save this document**

Directory

| | |
|--|---------------|
| 1. - SUMMARIZE | - 3 - |
| 2. - TECHNICAL PARAMETERS | - 5 - |
| 3. - INSTALLATION | - 7 - |
| 3.1. - MOUNTING | - 7 - |
| 3.2. - CONNECTION TERMINAL | - 8 - |
| 4. - COMMUNICATION INTERFACE..... | - 10 - |
| 4.1. - CONNECTION FOR RS485 | - 10 - |
| 4.2 - PRIVATE COMMUNICATION © PROTOCOL | - 11 - |
| 5. - SAFETY CONSIDERATIONS | - 16 - |
| 6. - MAINTENANCE | - 16 - |
| 7. - FAQs | - 17 - |

1. - SUMMARIZE

GYDCG-UBCH2 is a device used for online monitoring of the positive and negative electrode to ground insulation resistance of DC floating ground system. It can simultaneously monitor the ground insulation resistance of two DC systems (when two DC systems share the same ground). The two channels are controlled independently and can be monitored at the same time without interference. Users can realize the start and stop of insulation monitoring and data reading through RS485 communication.

The IMD can measure the insulation resistance value in the DC system of 100~1000V, the resistance ranges of 1KΩ~10MΩ, read unit by KΩ. When the insulation resistance value is greater than 10 MΩ, the insulation resistance data read value is 60000 (0xEA60), indicating infinity. If the read insulation resistance data is 65535 (0xFFFF), means the data is invalid. The invalid data (0xFFFF) indicates that the insulation monitoring function is not fully started, or is in the closed state, or the DC voltage is less than 100V.

This IMD adopts Dual-DC channels independent control scheme. Its schematic diagram is shown in the following figure. Users can control dual-channel startup, shutdown and data reading respectively according to the content of communication protocol. Take DC1 channel as an example. When the insulation monitoring function is disable, the positive and negative extreme relays K1 and K2 are disconnected, and the DC voltage and insulation resistance monitoring will not be provided at this time. When the host computer of the user sends the DC1 open instruction to IMD, K1 and K2 relays are closing, and the DC1 voltage is collected and insulation resistance is calculated immediately. The user can read the corresponding DC1 voltage and insulation resistance value. The application and principle of DC2 is same to DC1. Dual independent control. When the two insulation monitoring functions are closed, the K5 relay is disconnected and the IMD disconnects from the ground.

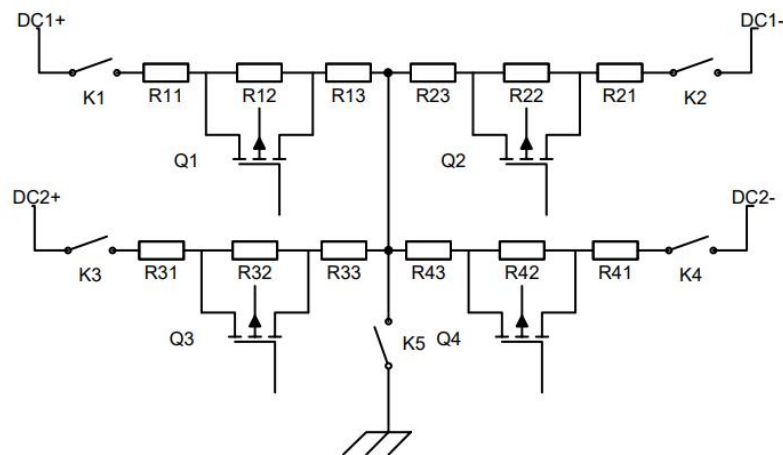

FEATURES

- Two independent control;
- Remote monitoring and management;
- Monitor positive and negative poles;
- Ground insulation resistance;
- DC voltage monitoring;
- Vehicle side DC voltage monitoring;
- Voltage reverse polarity alarm.

APPLICATIONS

- Guarantee the safety and stability of charging;
- Improvement of the efficiency and charging quality;
- Personnel and equipment security;
- Electric vehicle safety testing.

2. - TECHNICAL PARAMETERS

Basic parameters

| Parameter | Value | | |
|---|---|-------------------------|-----------------|
| Power supply | 9-30VDC, Power 6W | | |
| DC voltage range | 100V~1000V | | |
| DC voltage measurement accuracy | ≤2V+0.3% | | |
| Insulation resistance measurement range | 1KΩ~10 MΩ (DC System voltage:100V~1000V) | | |
| | C_Y range | Resistance range | Accuracy |
| Insulation monitoring accuracy (When :DC voltage:100V-1000V) | 0~0.8μF | ≤60kΩ 60kΩ<R≤1MΩ | ≤3kΩ ≤5% |
| | 0.8μF ~3μF | ≤60kΩ 60kΩ<R≤1MΩ | ≤6kΩ ≤20% |
| Off-line pressure test | <2mA | | |
| Standard | IEC 61851-23 (2014-03):2014-11 | | |
| Humidity | 85% | | |
| Storage temperature | - 40°C ~125°C | | |
| Operating temperature | - 40°C ~75°C | | |

Notes:

1.When facing the ground insulation resistance R_{ISO+} and negative insulation resistance to ground R_{ISO-} , The difference is too large, Multiplier of difference>10 times, R_{ISO+} and R_{ISO-} Large resistors may not be typical values.

2.C_Y Refers to the positive and negative Y capacitance values of the system bus to ground.

Other parameters

| Pressure point | Maximum voltage rating | Time |
|-----------------------------|-------------------------------|-------------|
| DC+/DC- to GND | 4200VDC/3000VAC | ≤1min |
| Power supply +/- to GND | 4200VDC/3000VAC | ≤1min |
| RS485 A/B to GND | 4200VDC/3000VAC | ≤1min |
| DC+/DC- to Power supply +/- | 4200VDC/3000VAC | ≤1min |
| DC+/DC- to A/B | 4200VDC/3000VAC | ≤1min |

3. - INSTALLATION

3.1. - Mounting

The module can be installed by guide rail or screw fixation. Guide rail using standard width 35mm. External dimensions are shown as follows: (Unit: mm)

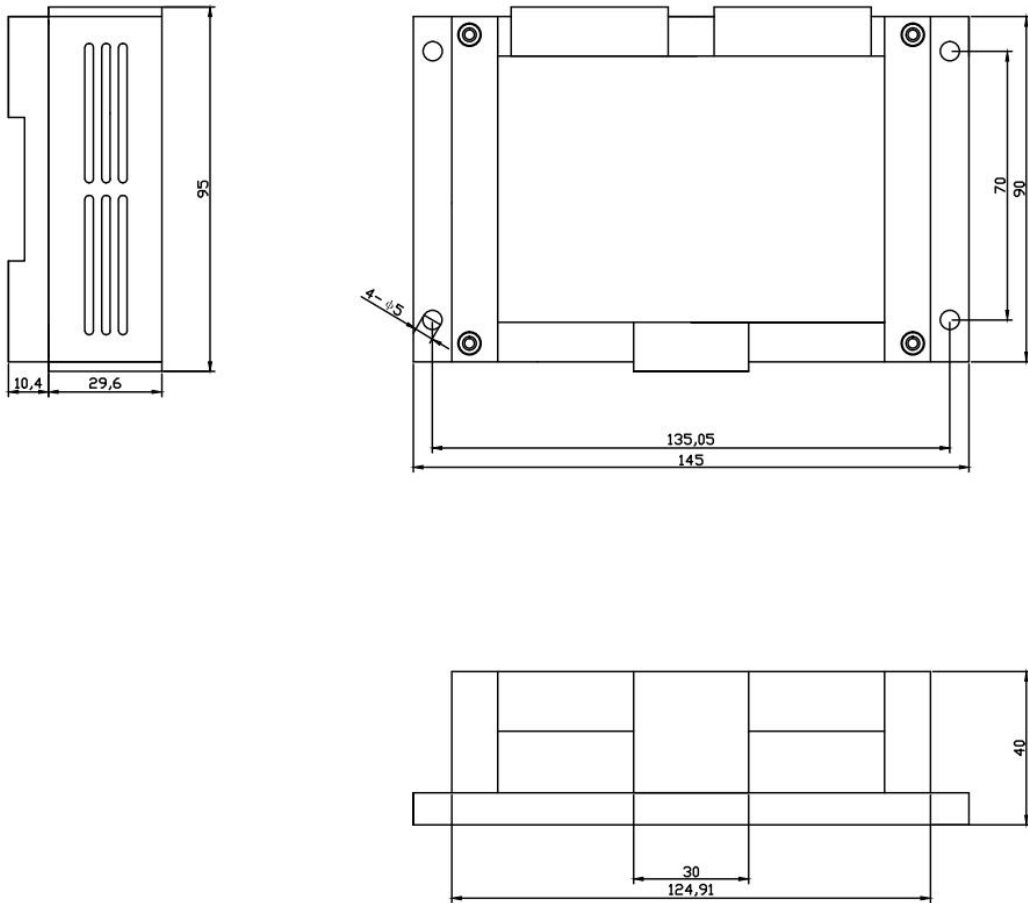

3.2. - Connection Terminal

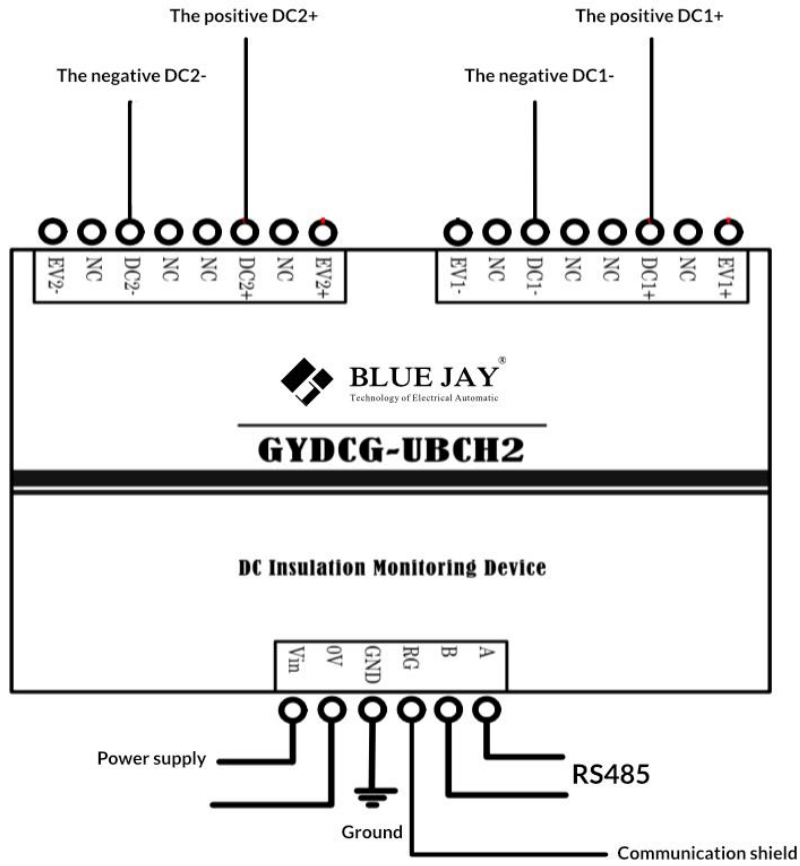

| Interface | Connection mode | Definition |
|-----------|--|--|
| DC1+ | Positive pole of DC 1 | DC1 interface |
| DC1- | Negative pole of DC 1 | |
| DC2+ | Positive pole of DC 2 | DC2 interface |
| DC2- | Negative pole of DC 2 | |
| Vin | Positive pole of power supply | 10-30VDC |
| 0V | Negative pole of power supply | |
| GND | Grounding point | |
| RG | 485 communication ground port (can leave it unwired) | Reserved, communication shielded line access point |
| A | 485A | |
| B | 485B | |

Note:

1. Without vehicle side voltage measurement, there is no need to connect the DC voltage EV+ and EV- on the vehicle side.

4. - COMMUNICATION INTERFACE

4.1. - Connection for RS485

Users can send data frames through the RS485 communication port to achieve: modify baud rate, modify communication address, enable or disable the insulation monitoring functions. By receiving data frames to check: communication address, whether the IMD can read DC voltage values, positive insulation resistance value, negative insulation resistance value. The initial address is A0H.

4.1.1 - Communication Parameter configuration bit

Two Dip switch configuration bit 'CONFIG', one of which can be used to configure the communication verification mode. E stands for EVEN parity and O stands for ODD parity. Touse the corresponding check sum, simply dial the corresponding position to "ON". If E and O are set to no, indicates NONE parity. See Figure 2.

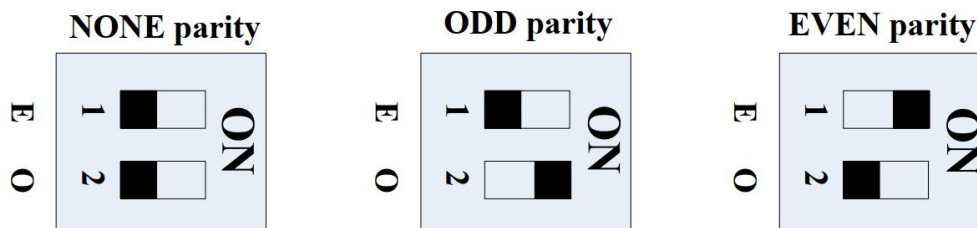

Figure 2 Configuration of communication verification mode

4.1.2 - Initializing Module Communication Parameters

Dip switch configuration bit 'CONFIG', second function can be used to initialize communication parameters. When E and O of CONFIG are dialed to ON at the same time foat least 3 seconds, the baud rate is restored to 9600bps and the communication address is restored to 01H and 02H. The system can be initialized only once after each power on. Thetotal number of times for modifying the baud rate, changing the communication address, andinitializing the baud rate must be less than 1 million. See Figure 3

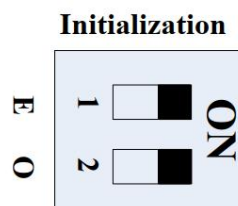

Figure 3 Initial configuration of communication parameters

4.2 - Private Communication © Protocol

Initial address: A0H, initial baud rate: 9600bps, check: (You can set the parity check mode by CONFIG), stop bit 1, data bit 8. The time interval between each byte in the sending frame must not exceed 20ms; otherwise, the frame will be cleared. This module works in slave mode.

GYDCG-UBCH2 adopts private Modbus protocol. Except for sending address command is variable. CRC is obtained according to the actual calculation, register data are defined and unchanged. Described as following:

4.2.1 - DC1 input relay control instructions

Instruction 1 Input relay closed

Host inquiry:

Addr. 97 00 00 00 00 00 00 CRC CRC

Slave response:

Addr. 97 00 00 00 00 00 00 CRC CRC

Instruction 2 Input relay is disconnected

Host inquiry:

Addr. 90 00 00 00 00 00 00 CRC CRC

Slave response:

Addr. 90 00 00 00 00 00 00 CRC CRC

4.2.2 - DC2 input relay control instructions

Instruction 1 Input relay closed

Host inquiry:

Addr. 9A 00 00 00 00 00 00 CRC CRC

Slave response:

Addr. 9A 00 00 00 00 00 00 CRC CRC

Instruction 2 Input relay is disconnected

Host inquiry:

Addr. 95 00 00 00 00 00 00 CRC CRC

Slave response:

Addr. 95 00 00 00 00 00 00 CRC CRC

4.2.3 - DC1 data reading instruction

Host inquiry: Addr. 01 00 00 00 00 00 00 CRC CRC

Slave response: Addr.
01
00(H): Dc voltage high bytes
00(L): Dc voltage low bytes
00(H): Positive insulation resistance high bytes
00(L): Positive insulation resistance low bytes
00(H): Negative insulation resistance high bytes
00(L): Negative insulation resistance low bytes
CRC: According to actual calculation
CRC: According to actual calculation

Slave response:
(reverse connection state > 150 VDC) Addr. 70 00 00 00 00 00 00 CRC CRC

Command example:

Host inquiry: A0 01 00 00 00 00 00 5A B3

Slave response: A0 01 01 A4 01 F4 00 78 6A 97

Slave response:
(reverse connection state) A0 70 00 00 00 00 00 78 3B B4

Reverse connection condition: When the insulation resistance of the positive and negative terminals to the ground is greater than 1 MΩ, the reverse voltage is greater than 150 VDC.

4.2.4 - Dc DC2 data reading instruction

Host inquiry: Addr. 03 00 00 00 00 00 00 00 CRC CRC

Slave response: Addr.
03
00(H): Dc voltage high bytes
00(L): Dc voltage low bytes
00(H): Positive insulation resistance high bytes
00(L): Positive insulation resistance low bytes
00(H): Negative insulation resistance high bytes
00(L): Negative insulation resistance low bytes
CRC: According to actual calculation
CRC: According to actual calculation

**Slave response:
(reverse connection state
> 150 VDC)** Addr. 80 00 00 00 00 00 00 00 CRC CRC

Command example:

Host inquiry: A0 03 00 00 00 00 00 00 5A B3

Slave response: A0 03 01 A4 01 F4 00 78 6A 97

**Slave response:
(reverse connection state)** A0 80 00 00 00 00 00 00 78 3B B4

When the insulation resistance of the positive and negative terminals to the ground is greater than $M\Omega$, the reverse voltage is greater than 150 VDC.

Notes:

Only when the DC voltage is between 100V~1000V, Insulation resistance monitoring can be realized. If DC voltage is low than 100V, or it is turned on within a short time, the insulation resistance read is 0xFFFF (means invalid number).

If the read insulation resistance value is a valid number, the insulation resistance value monitoring range is between $1K\Omega$ ~ $10M\Omega$. When the measured value is greater than $10M\Omega$, the value received by the communication is 0xEA60 (means infinity).

4.2.5 - Modified the power ON dip switch to ON position

Host inquiry: Addr. 40 New device addr. Reset baud rate 00 00 00 00 CRC CRC

Slave response: Addr.
40
New device address.
Reset baud rate
00(H): Negative insulation resistance high bytes
00(L): Positive insulation resistance low bytes
00(H): Negative insulation resistance high bytes
00(L): Negative insulation resistance low bytes
CRC: According to actual calculation
CRC: According to actual calculation

Command example:

(New device B0, baud rate 1200bps)
Host inquiry: A0 40 B0 12 00 00 00 00 A9 84

Slave response: B0 40 B0 12 00 00 00 00 A9 84

Baud rate specification:

0x12=1200bps; 0x24=2400bps; 0x48=4800bps; 0x96=9600bps; 0x14=14400bps;
0x19=19200bps.

5. - SAFETY CONSIDERATIONS



All installation specification described at the previous chapters named:
INSTALLATION AND STARTUP, INSTALLATION MODES and SPECIFICATIONS.

Please note that with the instrument powered on, the terminals could be dangerous to touching and cover opening actions or elements removal may allow accessing dangerous parts. This instrument is factory-shipped at proper operation condition.

- ◆ The device must have a professional installation and maintenance
- ◆ Any operation of the device, you must cut off the input signal and power;

6. - MAINTENANCE

The GYDCG-UBCH2 does not require any special maintenance. No adjustment, maintenance or repairing action should be done when the instrument is open and powered on, should those actions are essential, high-qualified operators must perform them.

Before any adjustment, replacement, maintenance or repairing operation is carried out, the instrument must be disconnected from any power supply source.

When any protection failure is suspected to exist, the instrument must be immediately put out of service. The instrument's design allows a quick replacement in case of any failure.

7. - FAQs

Question 1: The power indicator LED is off

Check whether the power supply terminal of the module is improperly connected, or the hot swap overcurrent causes the fuse to burn, try to avoid hot plug.

Question 2: Communication failure

Do not use USB-232-485 bipolar interface for communication, If the communication fails again, use the CONFIG mode to restore the factory Settings parameters. ([chapter4.1.2](#))

Question 3: The insulation monitoring resistance is infinite after the simulation of insulation resistance

Check whether the ground cable is connected reliably at GND port.

Question 4: The insulation monitoring resistance is much smaller than actual value

The DC ground capacitance may be too large. Check the DC ground capacitance

Question 5: Communication initialization is invalid

The system can be initialized only once by CONFIG during each power-on.

For any inquiry about the instrument performance or any failure, contact to Blue Jay's technical service.

Blue Jay - After-sales service

E-mail: tech@cqbluejay.com