

GYID Series Insulation Monitoring Device

GYID-10D36CAx-x

GYID-10M36CAx-x

User Manual

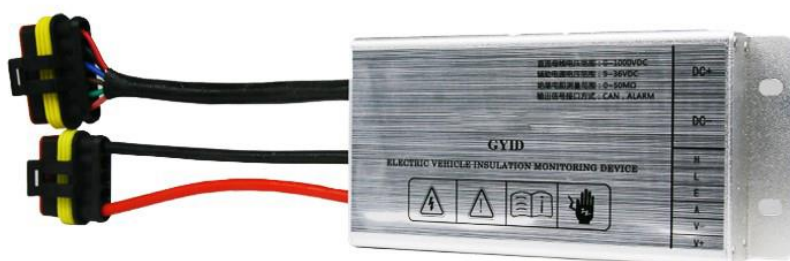

Version:1.10

Revision 2024.05

Read me

When you use GYID series, be sure to read this user manual carefully, and be able to fully understand the implications, the correct guidance of operations in accordance with user manual, which will help you make better use of GYID series, and help to solve the various problems at the scene.

1. Before turning on the power supply, be sure that the power supply within the provisions of the instrument;
2. When installation, the current input terminal must non-open, voltage input terminals must Non-short circuit;
3. Communication terminal (RS485) is strictly prohibited to impose on high pressure;
4. Be sure the instrument wiring consistent with the internal system settings;
5. When communicating with the PC, instrument communication parameters must be consistent with the PC.



- **Please read this user manual carefully**
- **Please save this document**

Directory

1. - SUMMARIZE	- 3 -
2. - TECHNICAL PARAMETERS	- 4 -
3. - INSTALLATION.....	- 6 -
3.1. - DIMENSION (UNIT: MM)	- 6 -
3.2. - CONNECTION TERMINAL	- 7 -
4 – WIRING METHOD.....	- 8 -
4.1 - TYPICAL APPLICATION	- 8 -
4.2 - CAN COMMUNICATION CIRCUIT	- 8 -
4.3 - WIRING INDICATION FOR ACTUAL VEHICLE APPLICATION	- 9 -
4.4 - ALARM CIRCUIT	- 9 -
5. - COMMUNICATION PROTOCOL.....	- 10 -
5.1 - COMMUNICATION PARAMETERS	- 10 -
5.2 - DATA DEFINITION	- 11 -
6. - MODEL SELECTION SHEET	- 12 -
7. - SAFETY CONSIDERATIONS	- 14 -
8. - MAINTENANCE	- 14 -
9. – FAQs.....	- 15 -

1. - SUMMARIZE

GYID series insulation monitor is used to monitor the insulation resistance between high voltage components (0-1000 Vdc. /0-750Vac.) and automobile chassis (earth) of power battery pack (pure electric or hybrid) power supply system in real time.

The measuring technology used in this product can monitor the insulation faults of DC side, AC side and motor side; can simultaneously monitor the asymmetric insulation faults of positive and negative poles and symmetrical insulation faults; can monitor the internal insulation faults of battery packs and locate the fault points; can monitor under the condition of short circuit of high voltage DC side; in the case of high intensity interference, such as acceleration, deceleration, energy recovery, the insulation resistance can be reliably monitored. fault information (insulation fault, overvoltage, self-error, etc.) is output through CAN bus interface.

FEATURES

- Monitor the positive and negative insulation resistance separately
- Monitor the total insulation resistance
- report the location of the battery insulation fault
- Automatically adapt to existing system Y capacitor C_Y ($C_Y \leq 4\mu F$)
- High internal resistance up to 10MOeInjected signal amplitude $\pm 15V$
- Fault response time $\leq 5s$
- High and low voltage side isolation voltage 3500 VD.C./2500 Vac.(rms)
- With CAN Bootloader, upgrade program by CAN

APPLICATIONS

- Monitor the insulation state
- DC floating system (IT system).
- Measuring battery pack DC voltage
- Continuous measurement of insulation resistance of 0~50M Ω
- Using the CAN bus interface

2. - TECHNICAL PARAMETERS

Power supply

9~36VDC

Input power

≤ 2W

Standard

IEC 61851-23 (2014-03):2014-11

DC voltage range

0V~1000V

DC voltage at pile side accuracy

≤2V+0.3%

Vehicle side voltage measurement range

0V~1000V

Insulation resistance measurement range

0~50MΩ

Insulation monitoring accuracy

±10 %

Bus voltage measurement accuracy

1 %

Insulation resistance measurement accuracy

0~100 KΩ, $C_Y \leq 2\mu\text{F}$, Bus voltage stability: ±12 KΩ

100 kΩ~1 MΩ, $C_Y \leq 2\mu\text{F}$, Bus voltage stability: ±10 %

1 MΩ~50 MΩ, $C_Y = 0\mu\text{F}$, Bus voltage stability: ±10 %

Insulation resistance measurement response time

$R_{ISO} \geq 500 \text{ k}\Omega$, $C_Y = 0\mu\text{F}$, Bus voltage stability: 4 s

$R_{ISO} \geq 500 \text{ k}\Omega$, $C_Y = 0\mu\text{F}$, Bus voltage stability: 5 s

$R_{ISO} = 1 \text{ M}\Omega$, $C_Y = 1\mu\text{F}$, Bus voltage stability: 8 s

$R_{ISO} = 1 \text{ M}\Omega$, $C_Y = 1\mu\text{F}$, Bus voltage stability: 12 s

DC equivalent internal resistance

Power on: 10.2 MΩ

Amplitude of injection pulse signal

±15 V

High to low voltage withstanding voltage

3 500 Vd.c. 2 500 Va.c.(rms)

Off-line pressure test

<2mA

Environment

Storage: - 40°C ~+85°C

Work: - 40°C ~85°C

Humidity:85%

3. - INSTALLATION

3.1. - Dimension (Unit: mm)

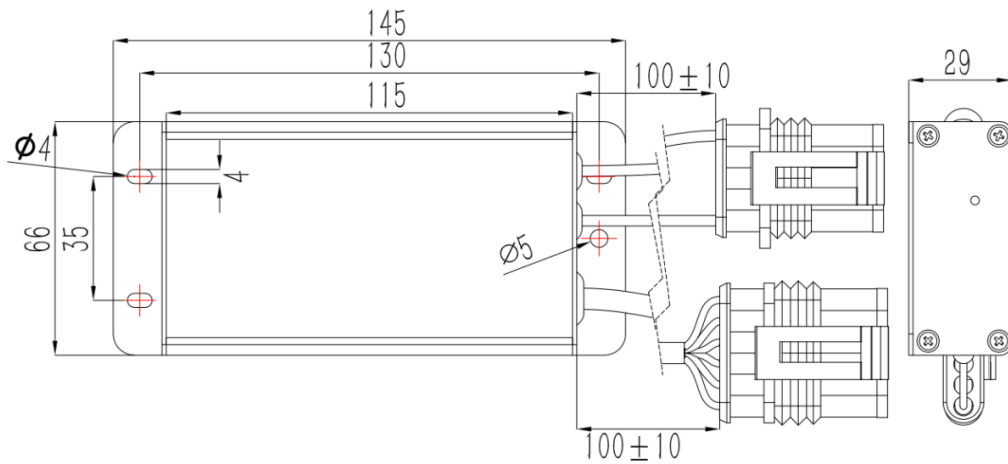

3.2. - Connection terminal

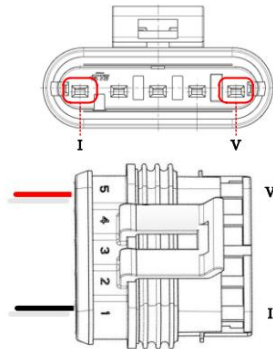

(a) Class B Voltage (High Voltage Side) Connector

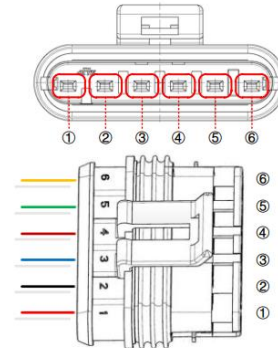

(b) Class A Voltage (Low Voltage Side) Connector

Voltage grade	Number/Color	Name	Wiring instructions
Class B voltage (High voltage side)	V red	DC+	Connect to battery positive BUS+
	I black	DC-	Connect to battery negative BUS-
Class A voltage (Low voltage side)	⑥ orange	H	Connect to CAN bus H port
	⑤ green	L	Connect to CAN bus L port
	④ brown	E	Connect the chassis of the car (earth)
	③ blue	A	Alarm output terminal (suspended if not required)
	② black	V-	Connect to auxiliary power supply negative pole
	① red	V+	Connect to auxiliary power supply positive pole

4. - WIRING METHOD

4.1 - Typical application

GYID series insulation monitor can be used in electric vehicle and hybrid electric vehicle, backup battery system, power grid energy storage and other occasions.

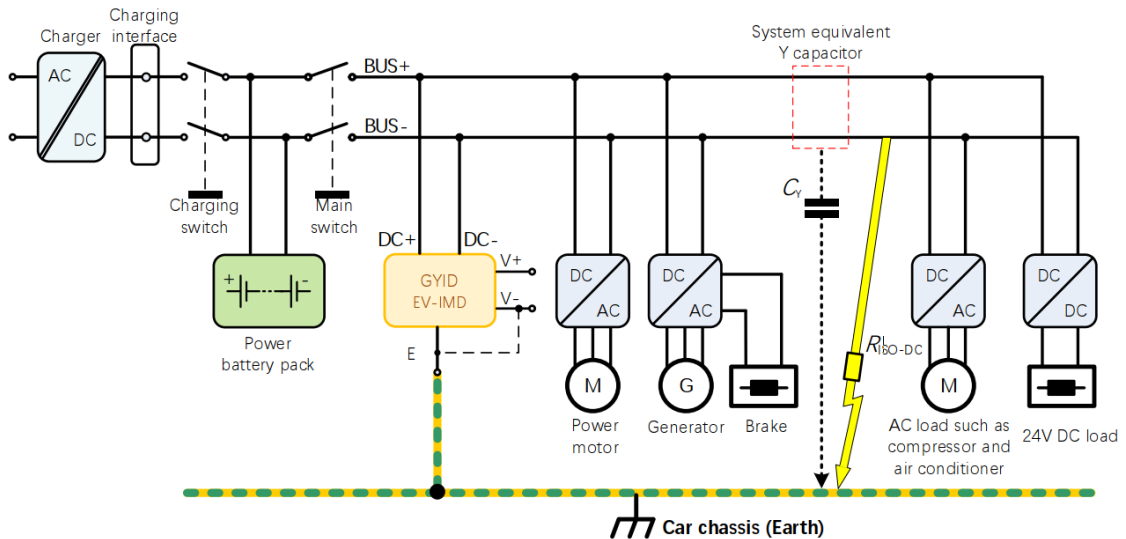

4.2 - CAN communication circuit

The CAN communication circuit of GYID series insulation monitor default connected with a terminal resistance of 120Ω.

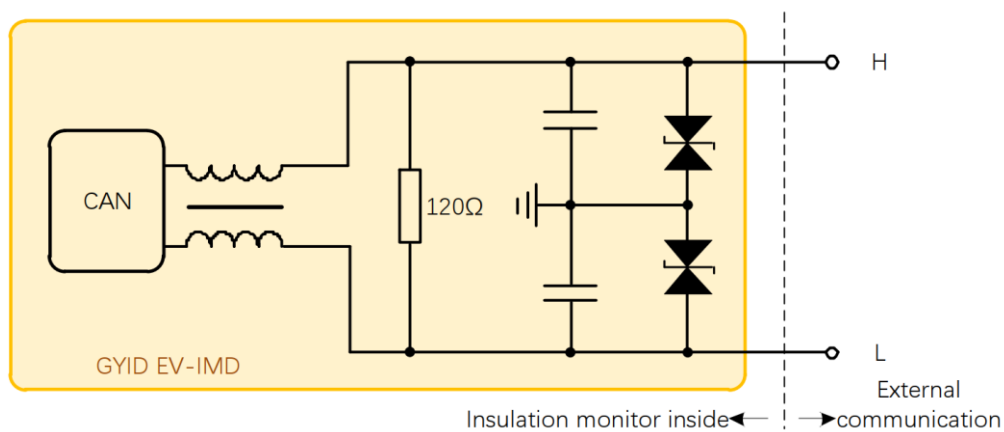

4.3 - Wiring indication for actual vehicle application

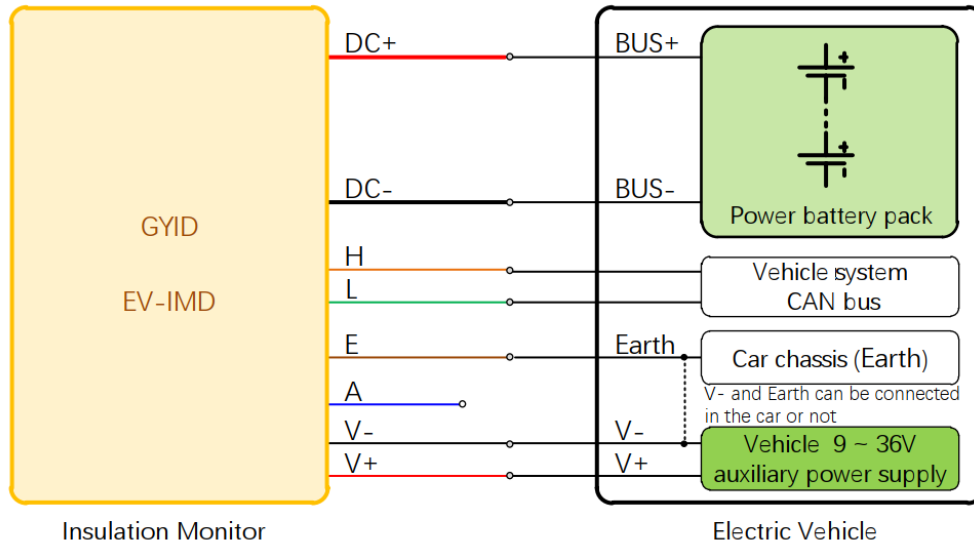

4.4 - ALARM circuit

The ALARM function of GYID series insulation monitor consists of optocoupler output. The negative end of the output of the optocoupler device in the insulation monitor has been connected with the negative end of the auxiliary power supply in the insulation monitor. Therefore, when the ALARM function is selected, users need to connect a resistor R and alarm indicator LED in series between the "A" port and the "V+" port to form a circuit, and ensure that the maximum current of the circuit does not exceed 100 mA.

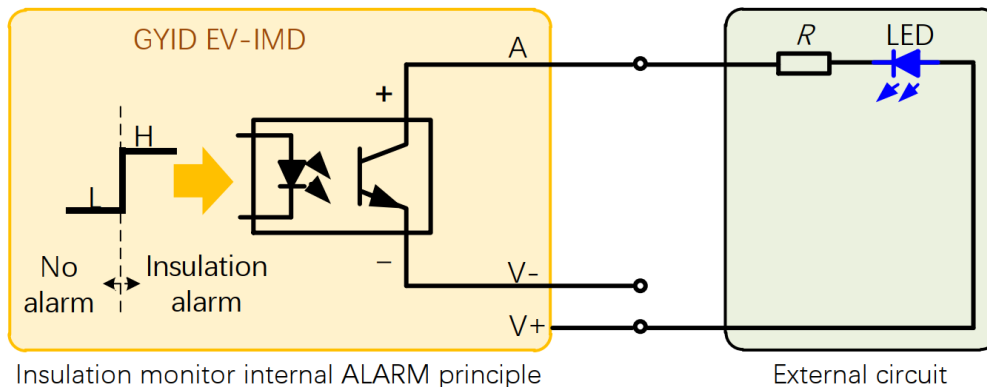

5. - COMMUNICATION PROTOCOL

5.1 - Communication parameters

Data	Parameter	Definition
Receiving ID	0x1819A1A5 (Extended frame)	<p>(1) Turn on insulation resistance monitoring Function command: 00 01 02 03 04 05 06 07</p> <p>(2) Turn off insulation resistance monitoring Function command: 07 06 05 04 03 02 01 00</p> <p>Default: 0x1819A1A5,adjustable</p>
Receiving cycle	10 ms	
Send ID	0x1819A1A4(Extended frame)	Default:0x1819A1A4,adjustable
Sending cycle	1s	Default: 1s,adjustable
Baud rate	250 kbps	Default: 250 kbps, adjustable

5.2 - Data definition

Byte	Bit	Definition
Byte 0	7	1:Insulation resistance monitoring function already started. 0:Insulation resistance monitoring function already stopped.
	6	1:Output R_{ISO+} and R_{ISO-} 0:Output R_{ISO}
	5	10: $R_{ISO+} > R_{ISO-}$ 01: $R_{ISO+} < R_{ISO-}$ 00: $R_{ISO+} = R_{ISO-}$
	4	
	3	Reserved (Default 0)
	2	1:Battery Overvoltage Alarm (Default: ∞ V , adjustable) 0:No Battery Overvoltage Alarm
	1	1:Level-2 Insulation Alarm (Default: 1 000 Ω /V , adjustable) 0:No Level-2 Insulation Alarm
	0	1:Level-1 Insulation Alarm (Default: 500 Ω /V , adjustable) ^① 0:No Level-1 Insulation Alarm

Byte	Bit	Definition
Byte 1~7	GYID-10D36CAx-x(output R_{ISO+} and R_{ISO-})	GYID-10M36CAx-x (output R_{ISO})
Byte 1	R_{ISO+} High byte /Unit k Ω	R_{ISO} High byte/Unit k Ω
Byte 2	R_{ISO+} Low byte	R_{ISO} Low byte
Byte 3	Battery Voltage VDC High byte ^② /Unit 0.1V	
Byte 4	Battery Voltage VDC Low byte	
Byte 5	R_{ISO-} High byte/Unit k Ω	Grounding position V1 High byte
Byte 6	R_{ISO-} Low byte	Grounding position V1 Low byte
Byte 7	Counting / 00~FF(HEX) cycle, plus 1 for each transmission cycle	

Notes:

① To type GYID-10D36CAx-x, the insulation alarm value equals $\min [R_{ISO+}, R_{ISO-}]$. To type GYID-10M36CAx-x, it equals R_{ISO} .

② The data converted from two bytes of battery voltage VDC to decimal contains one decimal point. Example: The two-byte data of battery voltage VDC is 04D2 (HEX), and the data converted into decimal system is 1234, then the battery voltage VDC = 123.4 V.

6. - MODEL SELECTION SHEET

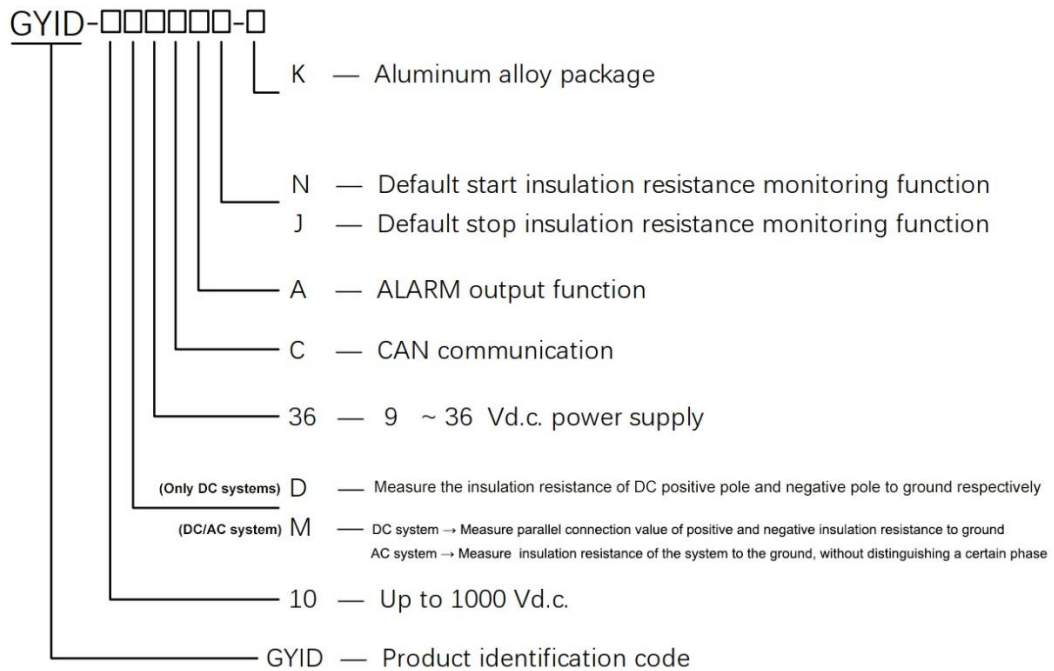

Notes: (must be read when selecting model)

Differences between GYID-10D36CAx-x and GYID-10M36CAx-x	
GYID-10D36CAx-x	GYID-10M36CAx-x
Only for DC floating systems	For both AC and DC floating systems
Measures the insulation resistance of the positive and negative poles of the output DC floating system to the ground, which are defined as R_{ISO+} and R_{ISO-} .	<p>For DC: measuring the parallel connection value of the positive and negative poles of the DC floating system to the ground insulation resistance, defined as R_{ISO}.</p> <p>For AC: measuring the ground insulation resistance of the AC floating system, without distinguishing a specific phase Line insulation fault, also defined as R_{ISO}.</p>

Notes:

when the measured DC system voltage VC (the voltage between DC+ and DC- terminals of the insulation monitor):

1. When the battery voltage VDC > 20 Vdc., the output positive and negative poles of the insulation monitor is R_{ISO+} and R_{ISO-} , respectively.
2. When the battery voltage VDC > 0 Vdc. and VDC is < 20 Vdc., the output positive and negative poles of the insulation monitor are equal to the ground insulation resistance respectively, and both are equal to the parallel value of the two. $R_{ISO+} = R_{ISO-}$

Note 2: items that can be adjustable according to user needs

- (1) CAN Communication Baud Rate: Default 250 kbps. (**Adjustable**)
- (2) Send ID: default 0x1819A1A4 (Extended frame).
- (3) CAN communication transmission cycle: Default 1s (Adjustable, but not recommended).
- (4) "Level-1 Insulation Alarm" Value: Default 500 Ω/V (Unit: Ω/V or k Ω , adjustable).
- (5) "Level-2 Insulation Alarm" Value: Default 1000 Ω/V (Unit: Ω/V or k Ω , adjustable).
- (6) "DC overvoltage alarm" Value: Default ∞ V, it is equivalent to no overvoltage alarm. (Adjustable).

7. - SAFETY CONSIDERATIONS



All installation specification described at the previous chapters named:
INSTALLATION AND STARTUP, INSTALLATION MODES and SPECIFICATIONS.

Please note that with the instrument powered on, the terminals could be dangerous to touching and cover opening actions or elements removal may allow accessing dangerous parts. This instrument is factory-shipped at proper operation condition.

- ◆ The device must have a professional installation and maintenance
- ◆ Any operation of the device, you must cut off the input signal and power;

8. - MAINTENANCE

GYID series does not require any special maintenance. No adjustment, maintenance or repairing action should be done when the instrument is open and powered on, should those actions are essential, high-qualified operators must perform them.

Before any adjustment, replacement, maintenance or repairing operation is carried out, the instrument must be disconnected from any power supply source.

When any protection failure is suspected to exist, the instrument must be immediately put out of service. The instrument's design allows a quick replacement in case of any failure.

9. – FAQs

Question 1: The insulation monitoring resistance is infinite after the simulation of insulation resistance

Check whether the ground cable is connected reliably at GND port.

Question 2: The insulation monitoring resistance is much smaller than actual value

The DC ground capacitance may be too large. Check the DC ground capacitance

For any inquiry about the instrument performance or any failure, contact to Blue Jay's technical service.

Blue Jay - After-sales service

E-mail: tech@cqbluejay.com