

AFR-3S

Arc Flash Protection Relay

User Manual



Version: 1.12

Revision: 2024.8

Read me

When you use AFR-3, be sure to read this user manual carefully, and be able to fully understand the implications, the correct guidance of operations in accordance with user manual, which will help you make better use of arc protection device, and help to solve the various problems at the scene.

1. This product must be earthed reliably.
2. Do not drop this product during installation to avoid damage to this product.
3. The terminal blocks must be connected firmly to avoid serious consequences caused by dropping.
4. Please do not plug or unplug the circuit board during the normal operation of this product; otherwise, the data of this product will be lost and the product may not operate normally.
5. The rated value is not changed randomly and it can be only changed by relevant professionals.
6. When installing, please install this product according to the terminal definition, and do not wire randomly.
7. After installation and energizing, do not touch the exposed terminals and the bare parts of the power supply and do not place this product in a damp area to avoid leakage and short circuit at the terminals.



- **Please read this user manual carefully**
- **Please save this document**

Directory

1. - SUMMARIZE	- 3 -
2. - FUNCTION INTRODUCTION	- 4 -
2.1 - ARC PROTECTION FUNCTION	- 4 -
2.2 - CIRCUIT BREAKER FAILURE PROTECTION FUNCTION	- 7 -
3. - SPECIFICATION	- 8 -
4.- INSTALLATION	- 10 -
4.1 - DIMENSION (UNIT: MM)	- 10 -
4.2 - TERMINAL DEFINITION	- 11 -
4.3 - INDICATOR DESCRIPTION	- 12 -
5. - COMMUNICATION INTERFACE	- 13 -
5.1. - MODBUS © PROTOCOL	- 13 -
5.2.- REGISTER MAP	- 14 -
6. - SAFETY CONSIDERATIONS	- 25 -
7. - MAINTENANCE	- 25 -

1. - SUMMARIZE

AFR-3S Arc flash relays are mainly used to detect arc faults in electrical systems and protect equipment and personnel in electrical systems from arc faults. The arc flash protection relay can detect arcs by monitoring parameters such as current, voltage, and electric power, and quickly disconnect the power supply before an electrical fire occurs, thereby reducing the risk of fire.

AFR-3S Arc flash relay is usually used in medium and high-voltage power distribution systems, control cabinets, transformers, generators, motors, and other electrical equipment. They adopt the dual-criteria principle of arc light detection and overcurrent detection and have the characteristics of fast protection action and high reliability.

FEATURES

- Dual criteria for arc detection and overcurrent detection;
- Complete exception records, event records, and operation records;
- All information power-off retention;
- Equipped with RS485 communication interface;
- Integrated MODBUS standard communication protocol;
- Small and exquisite appearance, reasonable structure;
- Using high-grade, high-quality components;
- Using multi-layer board technology and SMT process;
- The product has high electrical performance;
- Can collect 3 channels of arc light signals;
- Support ST visible light and ST ultraviolet sensor access.

APPLICATIONS

- Reduce the harm of arc light to human body;
- Reduce damage to equipment caused by arc short-circuit faults;
- Avoid transformer damage caused by bus failure;
- Protect the dc system in the station;
- Ensure the stable operation of power substations;
- Thermal power plant electrical section switchgear;
- Wind farm and photovoltaic station switchgear;
- Large municipal engineering project.

2. - Function Introduction

2.1 - Arc protection function

The device is equipped with 3 arc points, which are used to monitor the internal arc faults of the busbar room, circuit breaker room and cable room in the monitoring cabinet, and can choose to configure arc criterion, arc + current dual criterion for protection.

When the optical fiber transmits the light signal from the CT to the host, the host unit will issue an early warning. At the same time, the current sampling element inside the device will determine the real-time current value and the set value. If the real-time protection current is greater than the set value and an arc signal occurs at the same time, the device will send a trip signal to trip the cabinet.

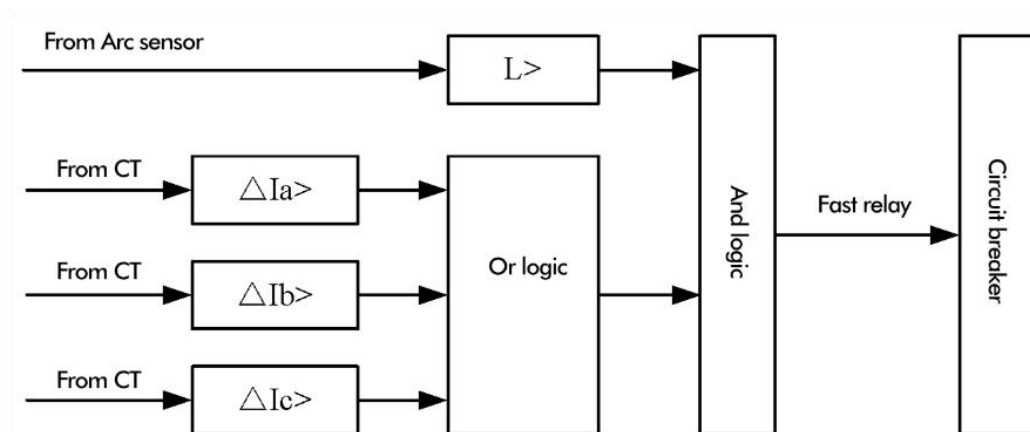

2.1.1 - Sensor introduction

Arc sensors are light sensing elements that detect arcs. When no arc fault occurs, the light intensity increases greatly, and the arc sensor converts the optical signal into an electrical signal and sends it to the arc protection or arc extension unit. Arc sensor wiring has no polarity.

The arc light sensor is installed in the relevant parts of the switchgear to monitor those fragile and important parts. Such as the busbar interval in the switchgear, the CT and PT components in the lower part of the switchgear, the contacts of the circuit breaker, the cable connector, etc.

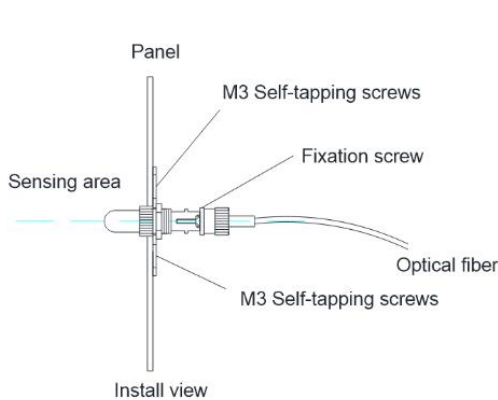
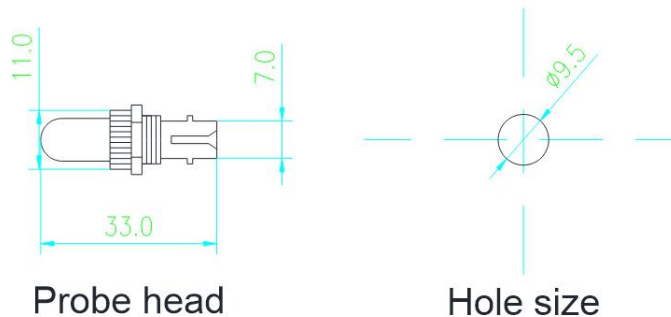

Notes: Suggest open hole 2.8mm diameter on switchgear panel for M3 screw

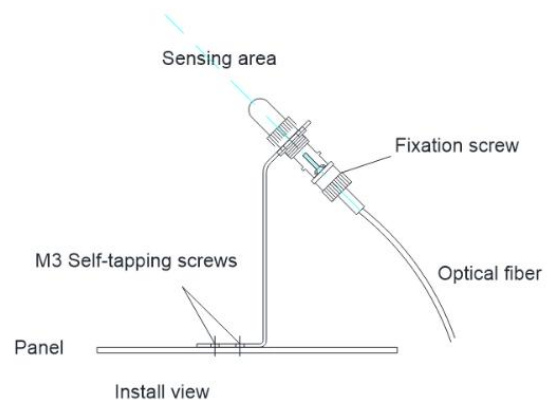

Notes: Suggest open hole 2.8mm diameter on switchgear panel for M3 screw

At present, there are three main types of arc light probes in the market: arc light probes, white light arc light sensing probes and ultraviolet arc light sensing probes. Among them, the ultraviolet arc light sensor has the strongest photosensitive ability, and is also the most effective in sensing arc ultraviolet light inside the switchgear. No interference and influence on visible light.

The ultraviolet arc light sensor is designed for arc light spectral characteristics, using special optical materials, polymer blending and doping technology, and optical lens technology. It can filter out the arc light detection sensor probe that interferes with visible light. The ultraviolet arc light probe can quickly detect the arc light that occurs within a range of more than 240 degrees, and transmit it to the control equipment through the optical fiber, so as to quickly cut off the fault at the millisecond level and avoid serious consequences.

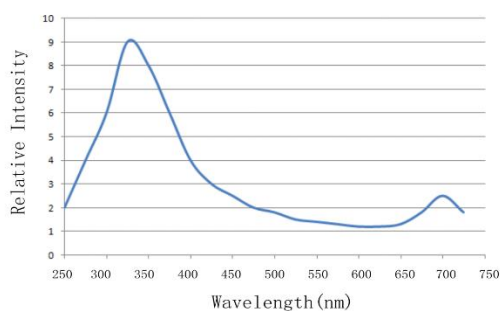
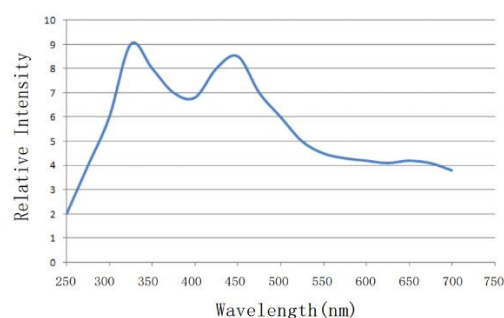
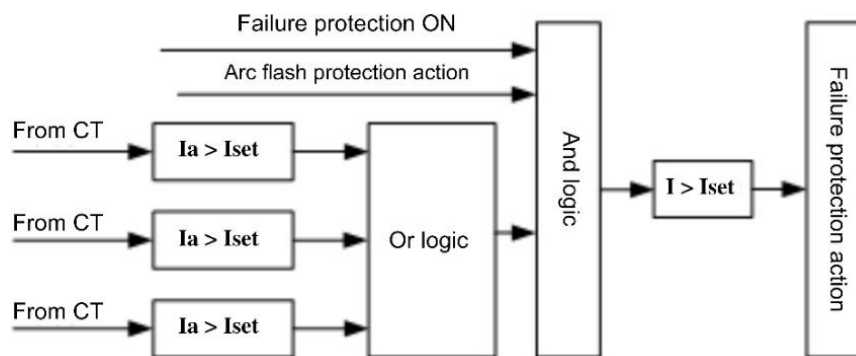

Fig1. UV spectral response curve

Fig2. Visible light spectrum response curve
Arc sensor parameter comparison:

Sensor type	Visible light sensor	UV light sensor
Sensitivity type	Full spectrum	UV spectrum
Spectral response bandwidth	250nm ~ 550nm	280nm ~ 400nm
Monitoring angle	-120°~ 120°	-120°~ 120°
Angle decay rate	≤20%	≤10%
Operating temperature	-30~70°C	-40~85°C
Interface type	ST fiber optic/nut fixation	ST optical fiber
Optical fiber maximum length	30 meters	40 meters

2.2 - Circuit breaker failure protection function

The device is equipped with circuit breaker failure protection. when the arc trip occurs, the device will judge the real-time value of the protection current. when the current is lower than the set value, the failure protection will not operate.

When delay occurs after the action, the current value is still higher than the set value, the device will activate the failure protection and output an independent trip signal to the upper level switch to cut off the fault.



3. - SPECIFICATION

Working power supply

Power supply	AC/DC 85~265V DC24/48V customized
Power consumption	Normal operation ≤8W; device action ≤10W

Current input

Rated current value	5A/1A
Measuring range	Protection current: 0.06~10In
Power consumption	≤0.5VA

Electrical parameter error

Protection current accuracy	≤±4%
Zero sequence current accuracy	≤±4%

Arc signal input

Number of channels	1-3 channels
Sensor type	ST optical fiber type
Detection light type	Visible/UV optional

Temperature measurement signal input (optional)

Number of channels	3-12 Channels
Sensor type	Passive/Active/Micro
Signal acquisition type	433M

Partial discharge signal input (optional)

Channels number	1 channel
Sensor type	Wire transmission
Detection light type	Geoelectric wave/Ultrasonic wave/Noise/UHF (optional)

Smoke sensor input (optional)

Channels number	1 way
Sensor type	External wired smoke sensor

Fire extinguishing sensor (optional)

Injection time	≤12S
Start mode	Electric start & thermal start
Protect space	≤3m ³
Component type	Aerosol fire extinguishing unit

Action time error

Pure arc trip	≤10ms
Current+arc trip	≤20ms

Alarm action time	≤40ms
Fire extinguishing spray lag time	≤3s
Relay output	
Channels number	4 channels (optional 6 channels)
Operating Voltage	AC250V/8A
Input	Passive contact, photoelectric isolation, isolation voltage 2500V
Communication Interface	
Communication Interface	1 channel, photoelectric isolation, with lightning protection
Baud rate	4800, 9600bps (default 9600)
Communication protocol	Modbus RTU
Ethernet communication	
Communication Interface	1 channel
Network parameters	10M/100M adaptive
Communication protocol	IEC60870-5-103 (NZ103)
Environment	
Working temperature	-25 ~ 70°C
Storage temperature	-40 ~ +85°C
Humidity	5~95%RH
Atmospheric pressure	60kPa~106kPa
Electromagnetic compatibility	
Electrostatic discharge test	GB/T 14598.14-2010 ,level-4
Fast transient dry resistance test	GB/T 14598.10-2007, level-A
1mhz burst interference test	GB/T 14598.13-2008, level-3
Electrical disturbance test	GB/T 14598.9-2010, level-3
Surge immunity test	GB/T 14598.18-2007
Conducted disturbance test	GB/T 14598.17-2005 ,22-6

4.- INSTALLATION

4.1 - Dimension (unit: mm)

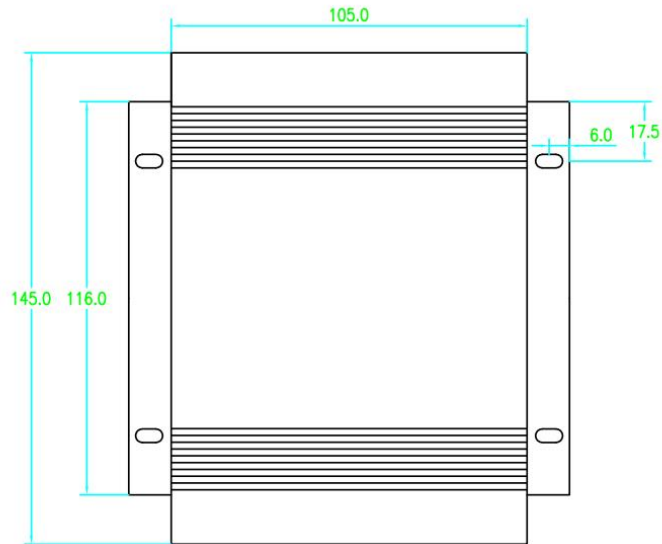

Front view

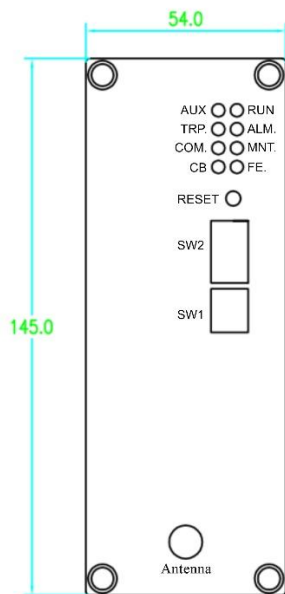

Side view

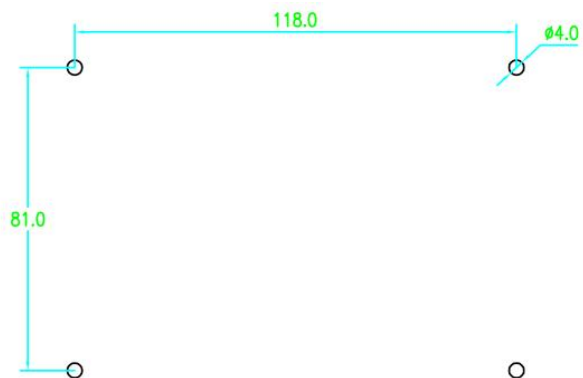

Hole size

4.2 - Terminal definition

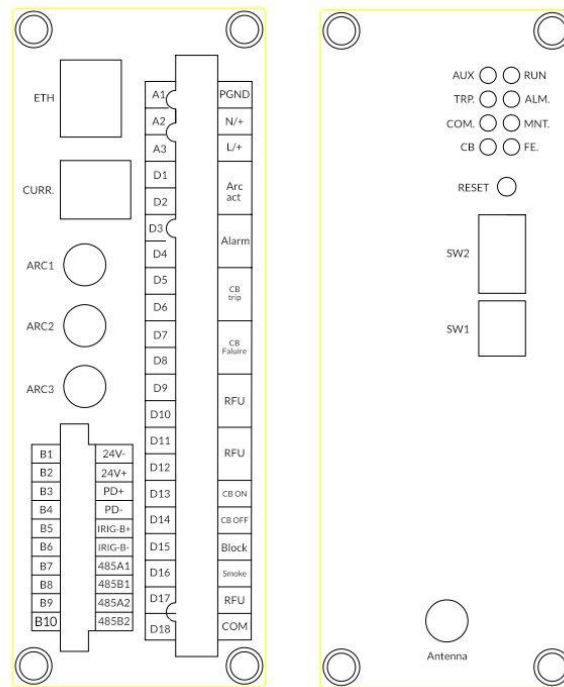

No.	Marked	Notes
	ETH	Ethernet interface (optional)
	Curr.	Current measuring interface
ARC 1-3	ARC1,2,3	Arc sensor
B1-B2	24V+,24V-	Sensor power supply: ±24V DC, load capacity: 400mA
B3-B4	PD+,PD-	Partial discharge sensor (optional)
B5-B6	IRIG-B+, IRIG-B-	Time synchronization function (optional)
B7-B8	485A1,485B1	Communication interface 1
B9-B10	485A2,485B2	Communication interface 2 (optional)

No.	Marked	Notes
A1	PGND	Ground wire
A2-A3	N/-, L+/-	Device power supply
D1-D2	Arc act	Act signal
D3-D4	Alarm	Alarm signal
D5-D6	CB trip	Trip signal
D7-D8	CB failure	Circuit breaker failure trip (optional)
D9-D10	RFU	Reserved function
D11-D12	RFU	Reserved function
D13-D14	CB ON/CB OFF	Circuit breaker opened/closed
D15	Block	Device maintenance
D16	Smoke	Smoke sensor (optional)
D17	RFU	Reserved function
D18	COM	Common terminal

4.3 - Indicator description

Indicator	Color	Description
"AUX"	Green	Device powered on.
"RUN"	Green	Device operates normally and flashes per second.
"TRP."	Red	Device tripped
"ALM."	Red	Device alarm action
"MNT."	Red	Maintain arc protection function
"COMM."	Green	Device communication status
"CB"	Green	CB ON/OFF signal
"FE."	Green	After Aerosol fire extinguisher action, normally light ON (This function is not enabled yet. For reference only)

5. - COMMUNICATION INTERFACE

5.1. - MODBUS © Protocol

Modbus RTU Frame Format:

Address code	1 BYTE	Slave device address 1-254
Function code	1 BYTE	Indicates the function codes like read coils / inputs
Data code	4 BYTE	Starting address, high byte Starting address, low byte Number of registers, high byte Number of registers, low byte
Error Check code	2 BYTE	Cyclical Redundancy Check (CRC)

Modbus Functions:

Code	Meaning	Description
FUNCTION 02	Read input status	Read the input status of the device bit by bit
FUNCTION 03/04	Read input registers	Read the analog quantity of the device
FUNCTION 05	Write single coil	Control CB ON/OFF and function selection
FUNCTION 06	Write single register	Writes a value into a single holding register.
FUNCTION 10	Write multiple register	Device time synchronization

Notes:

- The transmission mode of the device is RTU (remote terminal unit) mode, and the information transmission is asynchronous.
- Communication method: support RS485 communication method.
- Baud rate 2400/4800/9600/19200. Default is 9600.
- Start bit=1, data bit=8, stop bit=1, parity bit=none.
- This protocol adopts the standard calculation method of MODBUS RTU CRC16, and the verification sequence is (low-high).
- Physical address setting range: 1~254.

5.2.- Register Map

5.2.1 - Basic parameter, Read only, “03/04H” code to read

Addr.	Data	Type	Byte	Description
0x00 00	Ia	Float	4	Protection current secondary value
0x00 02	Ib	Float	4	Protection current secondary value
0x00 04	Ic	Float	4	Protection current secondary value
0x00 06	I0	Float	4	Zero-sequence current secondary value
0x00 08	T1	Float	4	Wireless temperature sensor
0x00 0A	T2	Float	4	Wireless temperature sensor
0x00 0C	T3	Float	4	Wireless temperature sensor
0x00 0E	T4	Float	4	Wireless temperature sensor
0x00 10	T5	Float	4	Wireless temperature sensor
0x00 12	T6	Float	4	Wireless temperature sensor
0x00 14	T7	Float	4	Wireless temperature sensor
0x00 16	T8	Float	4	Wireless temperature sensor
0x00 18	T9	Float	4	Wireless temperature sensor
0x00 1A	T10	Float	4	Wireless temperature sensor
0x00 1C	T11	Float	4	Wireless temperature sensor
0x00 1E	T12	Float	4	Wireless temperature sensor
0x00 20	Ultrasonic discharge times	Float	4	Partial discharge sensor test value
0x00 22	Ultrasonic discharge amplitude	Float	4	Partial discharge sensor test value
0x00 24	Ultrasonic discharge average times	Float	4	Partial discharge sensor test value
0x00 26	TEV discharge times	Float	4	Partial discharge sensor test value
0x00 28	TEV discharge amplitude	Float	4	Partial discharge sensor test value
0x00 2A	TEV discharge average times	Float	4	Partial discharge sensor test value
0x00 2C	Noise value	Float	4	Partial discharge sensor test value
0x00 2E	Ambient temperature	Float	4	Partial discharge sensor test value
0x00 30	Environment humidity	Float	4	Partial discharge sensor test value

Note: Float sequence is HH HL LH LL.

Example:

Host inquiry:

Data Format	Data	Description
Address	01H	Device address: 1-99
Function code	03/04H	Read input registers
Starting register H	00H	Starting register high byte
Starting register L	00H	Starting register low byte
Inquiry length H	00H	Inquiry length high byte
Inquiry length L	32H	Inquiry length low byte
CRC_H	XXH	CRC check code high byte
CRC_L	XXH	CRC check high low byte

Slave response:

Data Format	Data	Description
Address	01H	Device address
Function code	03/04H	Read input registers
Data length	64	Total data length
Data 1	Float 4	Basic parameters: 1-25
Data 2	Float 4	
Data 3	Float 4	
Data 4	Float 4	
...	Float 4	
Data 25	Float 4	
CRC_L	XXH	CRC check code low byte
CRC_H	XXH	CRC check high low byte

Command example

Host inquiry:

01 03 00 00 00 32 C4 1F

Slave response:

01 03 64 00 00 00 00 00 00 00 00 00 00 00 00 00 00 00 00 00 41 CB 33 33 41 CB 33 33 41 CC CC
 CD 41 CC CC CD 41 CC 00 00 41 CC 00 00 41 CC 00 00 41 C8 CC CD 41 C5 99 9A 41 CB 33
 33 41 C9 99 9A 41 C6 66 66 00 00 00 00 42 8C 00 00 43 35 00 00 00 00 00 00 40 80 00 00 40
 00 00 00 42 14 00 00 42 0C 66 66 42 1F 99 9A 4F B4

5.2.2 - Parameter query, Read only, “03H” code to read

Addr.	Type	Byte	Description
01 00	INT	2	Device communication address, Default:1
01 01	INT	2	Device operation password: Default:0
01 02	INT	2	Communication serial port 1 baud rate setting:4800,9600, Default:9600
01 03	INT	2	Backup serial port 2 baud rate setting:4800,9600, Default:9600
01 04	INT	2	Device name settings: Default:3 0: Arc protection device, 1: Cable head explosion-proof protection, 2: Switchgear explosion-proof protection, 3: Intelligent collection terminal.

Note: Real value=read value * 1

Example:

Host inquiry:

Data Format	Data	Description
Address	01H	Device address: 1-99
Function code	03H	Read input registers
Starting register H	01H	Starting register high byte
Starting register L	00H	Starting register low byte
Inquiry length H	00H	Inquiry length high byte
Inquiry length L	05H	Inquiry length low byte
CRC_H	XXH	CRC check code high byte
CRC_L	XXH	CRC check high low byte

Slave response:

Data Format	Data	Description
Address	01H	Device address
Function code	03H	Read input registers
Data length	0AH	Total data length
Data 1	INT 2	Device communication address
Data 2	INT 2	Device operation password
Data 3	INT 2	Communication serial port 1 baud rate setting
Data 4	INT 2	Backup serial port 2 baud rate setting
Data 5	INT 2	Device name settings
CRC_L	XXH	CRC check code low byte
CRC_H	XXH	CRC check high low byte

Command example

Host inquiry:

01 03 01 00 00 05 84 35

Slave response:

01 03 0A 00 01 00 00 25 80 25 80 00 03 65 28

5.2.3 - Parameter modification, Write only, “10H” code to write

Example:

Host inquiry:

Data Format	Data	Description
Address	01H	Device address: 1-99
Function code	10H	Device time synchronization
Starting <i>register</i> H	01H	Starting register high byte
Starting <i>register</i> L	00H	Starting register low byte
Data length H	00H	Data length high byte
Data length L	05H	Data length low byte
Data total bytes	0AH	8 bytes
Data 1	00 00	Parameter 1
Data 2	00 00	Parameter 2
Data 3	00 00	Parameter 3
...	00 00	Parameter 4
Data 5	00 00	Parameter 5
CRC_L	XXH	CRC check code high byte
CRC_H	XXH	CRC check high low byte

Slave response:

Data Format	Data	Description
Address	01H	Device address:1-99
Function code	10H	Device time synchronization
Starting <i>register</i> H	01H	Starting register high byte
Starting <i>register</i> L	00H	Starting register low byte
Data length H	00H	Data length high byte
Data length L	05H	Data length low byte
CRC_L	XXH	CRC check code low byte
CRC_H	XXH	CRC check high low byte

Command example

Host inquiry:

01 10 01 00 00 05 0A 00 02 00 00 25 80 25 80 00 03 95 96

Slave response:

01 10 01 00 00 05 01 F6

Modify communication address to 2

Modify operation password to 0

Modify communication serial port 1 baud rate setting to 9600

Modify backup serial port 2 baud rate setting to 9600

Modify device name to "Intelligent collection terminal".

5.2.4 - Setting value query, Read only, “03H” code to read.

Addr.	Type	Byte	Description
03 00	INT	2	Arc protection trip control byte, Unit:1. 0-Exit, 1-Pure arc trip, 2-Double criterion trip. Default: 0
03 01	INT	2	Arc protection current setting value: 0.25A - 99.00A, Unit: 0.01A. Default: 5
03 02	INT	2	Arc protection delay setting value: 0.00S - 10.00S, Unit: 0.01S. Default: 0
03 03	INT	2	1# Arc Trip: 0: OFF; 1: ON, Unit:1. Default: 0
03 04	INT	2	2# Arc Trip: 0: OFF; 1: ON, Unit:1. Default: 0
03 05	INT	2	3# Arc Trip: 0: OFF; 1: ON, Unit:1. Default: 0
03 06	INT	2	Arc protection alarm control byte: 0: OFF; 1: ON, Unit:1. Default: 0
03 07	INT	2	1# Arc Alarm: 0: OFF; 1: ON, Unit:1. Default: 0
03 08	INT	2	2# Arc Alarm: 0: OFF; 1: ON, Unit:1. Default: 0
03 09	INT	2	3# Arc Alarm: 0: OFF; 1: ON, Unit:1. Default: 0
03 0A	INT	2	Quick-break overcurrent protection control byte: 0: OFF; 1: ON, Unit:1. Default: 0
03 0B	INT	2	Quick-break overcurrent setting value: 0.25A - 99.00A, Unit:0.01A. Default: 5
03 0C	INT	2	Quick-break overcurrent delay setting value: 0.00S - 10.00S, Unit:0.01S. Default: 0
03 0D	INT	2	Time-limited overcurrent protection control byte: 0: OFF; 1: ON, Unit:1. Default: 0
03 0E	INT	2	Time-limited overcurrent current setting value: 0.25A - 99.00A, Unit: 0.01A. Default: 3
03 0F	INT	2	Time-limited overcurrent delay setting value: 0.00S - 10.00S, Unit: 0.01S. Default: 1
03 10	INT	2	Overcurrent protection control byte: 0: OFF; 1: ON, Unit: 1. Default: 0
03 11	INT	2	Overcurrent current setting value: 0.25A - 99.00A, Unit: 0.01A. Default: 3
03 12	INT	2	Overcurrent delay setting value: 0.00S - 10.00S, Unit: 0.01S. Default: 2
03 13	INT	2	Zero sequence protection control byte: 0-Exit, 1-Alarm, 2-Trip, Unit: 1. Default: 0
03 14	INT	2	Zero sequence current setting value: 0.05A -20.00A, Unit: 0.01A. Default: 1
03 15	INT	2	Zero sequence delay setting value: 0.00S - 10.00S, Unit: 0.01S. Default: 0
03 16	INT	2	Overload protection control byte: 0-Exit, 1-Alarm, 2-Trip, Unit: 1. Default: 0
03 17	INT	2	Overload protection current setting value: 0.5A -20.00A, Unit: 1A. Default: 2
03 18	INT	2	Overload protection delay setting value: 0.00S - 999.9S, Unit: 1S. Default: 5
03 19	INT	2	Failure protection trip control byte: 0: OFF; 1: ON, Unit: 1. Default: 0
03 1A	INT	2	Failure protection current setting value: 0.25A -99.00A, Unit: 1A. Default: 1
03 1B	INT	2	Failure protection delay setting value:

			0.00S - 10.00S, Unit: 1S. Default: 0.3
03 1C	INT	2	Smoke warning control byte: 0-Exit, 1-Alarm, 2-Trip, Unit: 1. Default: 0
03 1D	INT	2	Smoke alarm delay: 0.00S - 99.99S, Unit: 1S. Default: 2
03 1E	INT	2	Temperature warning control byte: 0: OFF; 1: ON, Unit: 1. Default: 0
03 1F	INT	2	Temperature warning setting value: 0 – 100°C, Unit: 1°C. Default: 55°C
8 02	INT	2	Temperature warning delay: 00.0S – 999.9S, Unit: 1S. Default: 30
8 03	INT	2	Temperature alarm control byte: 0: OFF; 1: ON, Unit: 1. Default: 0
8 04	INT	2	Temperature alarm setting value: 0 – 100°C, Unit: 1°C. Default: 75°C
8 05	INT	2	Temperature alarm delay: 00.0S – 999.9S, Unit: 1. Default: 60
8 06	INT	2	Ultrasonic alarm control byte: 0: OFF; 1: ON, Unit: 1. Default: 0
9 01	INT	2	Ultrasonic alarm setting value: 10 – 60dBuV, Unit: 1 dBuV. Default: 45 dBuV
9 02	INT	2	Ultrasonic discharge times: 10-99, Unit: 1. Default: 30
9 03	INT	2	TEV alarm control byte: 0: OFF; 1: ON, Unit: 1. Default: 0
9 04	INT	2	TEV alarm setting value: 10 – 60dBuV, Unit: 1 dBuV. Default: 45 dBuV
9 05	INT	2	TEV discharge times: 10-99, Unit: 1. Default: 30
9 06	INT	2	Fire extinguishing control byte: 0: OFF; 1: ON, Unit: 1. Default: 0
10 01	INT	2	Ambient temperature setting value: 0 – 100°C, Unit: 1°C. Default: 55°C
10 02	INT	2	Fire extinguishing control delay: 0.00S - 999.9S, Unit: 1S. Default: 30S

5.2.5 - Setting value modification, Write only, “10H” code to write

Example:

Host inquiry:

Data Format	Data	Description
Address	01H	Device address: 1-99
Function code	10H	Device time synchronization
Starting register H	03H	Starting register high byte
Starting register L	00H	Starting register low byte
Data length H	00H	Data length high byte
Data length L	03H	Data length low byte
Data total bytes	06H	8 bytes
Data 1	00 00	Parameter 1
Data 2	00 00	Parameter 2
Data 3	00 00	Parameter 3
CRC_L	XXH	CRC check code high byte
CRC_H	XXH	CRC check high low byte

Slave response:

Data Format	Data	Description
Address	01H	Device address:1-99
Function code	10H	Device time synchronization
Starting <i>register</i> H	03H	Starting register high byte
Starting <i>register</i> L	00H	Starting register low byte
Data length H	00H	Data length high byte
Data length L	03H	Data length low byte
CRC_L	XXH	CRC check code low byte
CRC_H	XXH	CRC check high low byte

Command example

Host inquiry:

01 10 03 00 00 03 06 00 02 01 90 00 C8 90 43

Slave response:

01 10 03 00 00 03 80 4C

Modify data 1-3 setting values from: 1; 5.00; 1.00; to 2; 4.00; 2.00

5.2.6 - Function modification, Write only, “05H custom protocol” code to write

Addr.	Data	Default
0AH	Phase overcurrent: 01:OFF ; 02:ON	OFF
0BH	Arc flash trip: 01:OFF ; 02:ON	OFF
0CH	Arc flash alarm: 01:OFF ; 02:ON	OFF
0DH	Zero-sequence overcurrent: 01:OFF ; 02:ON	OFF
0EH	Overload protection: 01:OFF ; 02:ON	OFF
0FH	Smoke alarm: 01:OFF ; 02:ON	OFF
10H	Circuit breaker failure: 01:OFF ; 02:ON	OFF
11H	Temperature alarm: 01:OFF ; 02:ON	OFF
12H	Ultrasonic alarm: 01:OFF ; 02:ON	OFF
13H	TEV alarm: 01:OFF ; 02:ON	OFF
14H	Fire extinguishing control actions: 01:OFF ; 02:ON	OFF

Example:

Host inquiry:

Data Format	Data	Description
Address	01H	Device address
Function code	05H	Device time synchronization
Function ID	0AH	Function 1
Modification method	02H	Turn ON/OFF
	FFH	
	00H	
CRC_L	XXH	CRC check code high byte
CRC_H	XXH	CRC check high low byte

Slave response:

Data Format	Data	Description
Address	01H	Device address
Function code	05H	Device time synchronization
Function ID	0AH	Function 1
Modification method	02H	Turn ON/OFF
	FFH	
	00H	
CRC_L	XXH	CRC check code high byte
CRC_H	XXH	CRC check high low byte

Command example

Host inquiry:

01 05 0A 02 FF 00 2E 22

Slave response:

01 05 0A 02 FF 00 2E 22

Turn ON 1#Function

Host inquiry:

01 05 14 01 FF 00 D8 0A

Slave response:

01 05 14 01 FF 00 D8 0A

Turn OFF 11#Function

5.2.7 - Read DI Signal, Read only, “02H” code to read

Addr.	Bit	Data	Description
00	0	General act signal	0:Opened ; 1:Closed
	1	General alarm signal	0:Opened ; 1:Closed
	2	1DL OFF	0:Opened ; 1:Closed
	3	1DL ON	0:Opened ; 1:Closed
	4	Maintain arc	0:Opened ; 1:Closed
	5	Smoke 1	0:Opened ; 1:Closed
	6	Fire extinguishing elements	0:Opened ; 1:Closed
	7	Reserve	0:Opened ; 1:Closed
01	0	ARC1	0:Opened ; 1:Closed
	1	ARC2	0:Opened ; 1:Closed
	2	ARC3	0:Opened ; 1:Closed
	3		0:Opened ; 1:Closed
	4		0:Opened ; 1:Closed
	5		0:Opened ; 1:Closed
	6		0:Opened ; 1:Closed
	7		0:Opened ; 1:Closed
02	0	Phase overcurrent	0:OFF ; 1:ON
	1	Arc trip	0:OFF ; 1:ON
	2	Arc alarm	0:OFF ; 1:ON
	3	Zero sequence overcurrent	0:OFF ; 1:ON
	4	Overburden protection	0:OFF ; 1:ON
	5	Smoke alarm	0:OFF ; 1:ON
	6	CB trip failure	0:OFF ; 1:ON
	7	Temperature alarm	0:OFF ; 1:ON
03	0	Ultrasonic alarm	0:OFF ; 1:ON
	1	TEV alarm	0:OFF ; 1:ON
	2	Fire extinguishing control actions	0:OFF ; 1:ON
	3		
	4		
	5		
	6		
	7		
04	0	Protection start	0: Return; 1: Action
	1	Arc trip	0: Return; 1: Action
	2	Quick-break overcurrent protection	0: Return; 1: Action
	3	Limited time overcurrent protection action	0: Return; 1: Action

	4	Overcurrent protection action	0: Return; 1: Action
	5	Zero sequence overcurrent action	0: Return; 1: Action
	6	Overload protection action	0: Return; 1: Action
	7	Failure protection action	0: Return; 1: Action
05	0	Smoke action	0: Return; 1: Action
	1	Fire extinguishing control actions	0: Return; 1: Action
	2	Reserve	
	3	Reserve	
	4	Reserve	
	5	Reserve	
	6	Reserve	
	7	Reserve	
06	0	Rated value fails	0: Return; 1: Alarm
	1	Parameter fail	0: Return; 1: Alarm
	2	Device parameter fail	0: Return; 1: Alarm
	3	FLASH fail	0: Return; 1: Alarm
	4	AD fail	0: Return; 1: Alarm
	5	Zero drift limit	0: Return; 1: Alarm
	6	Communication initialization fail	0: Return; 1: Alarm
	7	output break down	0: Return; 1: Alarm
07	0	Control loop disconnection	0: Return; 1: Alarm
	1	Spring discharged	0: Return; 1: Alarm
	2	Arc protection alarm	0: Return; 1: Alarm
	3	Zero sequence overcurrent alarm	0: Return; 1: Alarm
	4	Overload alarm	0: Return; 1: Alarm
	5	Smoke alarm	0: Return; 1: Alarm
	6		0: Return; 1: Alarm
	7	Busbar temperature warning	0: Return; 1: Alarm
08	0	Cable head temperature warning	0: Return; 1: Alarm
	1	Upper contact temperature warning	0: Return; 1: Alarm
	2	Lower contact temperature warning	0: Return; 1: Alarm
	3	Busbar temperature alarm	0: Return; 1: Alarm
	4	Cable head temperature alarm	0: Return; 1: Alarm
	5	Upper contact temperature alarm	0: Return; 1: Alarm
	6	Lower contact temperature alarm	0: Return; 1: Alarm
	7	Ultrasonic alarm	0: Return; 1: Alarm
09	0	TEV alarm	0: Return; 1: Alarm
	1		
	2		

	3		
	4		
	5		
	6		
	7		

Example:

Host inquiry:

Data Format	Data	Description
Address	01H	Device address: 1-99
Function code	02H	Read DI signal
Starting <i>register</i> H	00H	Starting register high byte
Starting <i>register</i> L	00H	Starting register low byte
Inquiry length H	00H	Inquiry length high byte
Inquiry length L	50H	Inquiry length low byte
CRC_L	XXH	CRC check code high byte
CRC_H	XXH	CRC check high low byte

Slave response:

Data Format	Data	Description
Address	01H	Device address:1-99
Function code	02H	Read DI signal
Data length	0EH	Total data length
Data 1	00H	ID: 00 Bit:0-7
Data 2	00H	ID: 01 Bit:0-7
Data 3	00H	ID: 02 Bit:0-7
...	00H	...
Data 9	00H	ID: 09 Bit:0-7
CRC_L	XXH	CRC check code low byte
CRC_H	XXH	CRC check high low byte

Command example

Host inquiry:

01 02 00 00 00 50 78 36

Slave response:

01 02 0A 00 00 23 06 00 00 00 00 00 1B BD 73

5.2.8 - Clock query, Read only, “03H” code to read

Example:

Host inquiry:

Data Format	Data	Description
Address	01H	Device address: 1-99
Function code	03H	Read input registers
Starting register H	05H	Starting register high byte
Starting register L	00H	Starting register low byte
Inquiry length H	00H	Inquiry length high byte
Inquiry length L	08H	Inquiry length low byte
CRC_H	XXH	CRC check code high byte
CRC_L	XXH	CRC check high low byte

Slave response:

Data Format	Data	Description
Address	01H	Device address
Function code	03H	Read input registers
Data length	08H	Total data length
Year	07 E7	2023
Month	04H	April
Day	14H	20th
Hour	0FH	15 o'clock
Minute	11H	17min
Second	2F B8	12s 216ms

Example:

Command example

Host inquiry:

01 03 05 00 00 08 44 C0

Slave response:

01 03 08 07 E7 04 14 0F 11 2F B8 3D EB

5.2.9 - Clock modification, Write only, “10H” code to write

Example:

Host inquiry:

Data Format	Data	Description
Address	01H	Device address: 1-99
Function code	10H	Device time synchronization
Starting register H	00H	Starting register high byte
Starting register L	00H	Starting register low byte
Data length H	08H	Data length H
Data length L	00H	Data length L
Data total bytes	08H	8 bytes
Year H	07H	2021
Year L	E5H	
Month	0AH	October
Day	09H	9th
Hour	0BH	11 o'clock
Minute	05H	5 min
Second H	3EH	15s 877ms
Second L	05H	
CRC_L	XXH	CRC check code high byte
CRC_H	XXH	CRC check high low byte

Slave response:

Data Format	Data	Description
Address	01H	Device address: 1-99
Function code	10H	Device time synchronization
Starting <i>register</i> H	00H	Starting register high byte
Starting <i>register</i> L	00H	Starting register low byte
Data length H	00H	Data length H
Data length L	00H	Data length L
Data total bytes	08H	8 bytes
Year H	07H	2021
Year L	E5H	
Month	0AH	October
Day	09H	9th
Hour	0BH	11 o'clock
Minute	05H	5 min
Second H	3EH	15s 877ms
Second L	05H	
CRC_L	XXH	CRC check code high byte
CRC_H	XXH	CRC check high low byte

Command example

Host inquiry:

01 10 00 00 08 00 08 07 E7 04 14 0B 1B 00 00 48 83

Slave response:

01 10 00 00 08 00 08 07 E7 04 14 0B 1B 00 00 48 83

Modify device time to: April 20, 2023 11:27

5.2.10 - Ethernet IP address query, Read only, “03H” code to read

Example:

Host inquiry:

Data Format	Data	Description
Address	01H	Device address:1-99
Function code	03H	Read input registers
Starting <i>register</i> H	06H	Starting register high byte
Starting <i>register</i> L	00H	Starting register low byte
Inquiry length H	00H	Inquiry length high byte
Inquiry length L	08H	Inquiry length low byte
CRC_L	XXH	CRC check code low byte
CRC_H	XXH	CRC check high low byte

Slave response:

Data Format	Data	Description
Address	01H	Device address:1-99
Function code	03H	Read input registers
Data length	08H	Total data length
	C0H	192
IP address	A8H	168
	0BH	11
	02H	2
	FFH	255
Sub-net mask	FFH	255
	00H	0
	00H	0
CRC_L	XXH	CRC check code low byte
CRC_H	XXH	CRC check high low byte

Command example

Host inquiry:

01 03 06 00 00 08 44 84

Slave response:

01 03 08 C0 A8 0B 02 FF FF 00 00 C8 D2

C0 A8 0B 02 Ethernet IP address is 192.168.11.2,
 FF FF 00 00 Ethernet Sub-net mask is 255.255.0.0.

5.2.11 - Ethernet IP address modification, Write only, “10H” code to write

Example:

Host inquiry:

Data Format	Data	Description
Address	01H	Device address:1-99
Function code	10H	Read input registers
Starting register H	06H	Starting register H
Starting register L	00H	Starting register L
Data length H	00H	Data length H
Data length L	04H	Data length L
Total data bytes	04H	8 bytes
Data 1	C0H	192
Data 2	A8H	168
Data 3	0CH	11
Data 4	02H	2
CRC_L	XXH	CRC check code low byte
CRC_H	XXH	CRC check high low byte

Command example

Host inquiry:

01 10 06 00 00 04 04 C0 A8 0C 02 E1 48

No slave response

After modification is successful, device will automatically restart, so no reply to this message. If there is a reply message, it means the IP address modification failed

5.2.12 - Communication address query, Read only, "03H" code to read

Example:

Host inquiry:

Data Format	Data	Description
Address	FFH	Default
Function code	03H	Read input registers
Starting register H	01H	Starting register high byte
Starting register L	00H	Starting register low byte
Inquiry length H	00H	Inquiry length high byte
Inquiry length L	01H	Inquiry length low byte
CRC_L	XXH	CRC check code low byte
CRC_H	XXH	CRC check high low byte

Slave response:

Data Format	Data	Description
Address	01H	Device address
Function code	03H	Read input registers
Data length	5AH	Total data length
Data 1	00 02	Device address 2
CRC_L	XXH	CRC check code low byte
CRC_H	XXH	CRC check high low byte

Command example

Host inquiry:

FF 03 01 00 00 01 90 28

Slave response:

FF 03 02 00 02 10 51

5.2.13 -Signal reset, Write only, “06H” code to write

Example:

Host inquiry:

Data Format	Data	Description
Address	01H	Device address: 1-99
Function code	06H	Signal return
Starting register H	00H	Starting register high byte
Starting register L	00H	Starting register low byte
Inquiry length H	00H	Inquiry length high byte
Inquiry length L	00H	Inquiry length low byte
CRC_L	XXH	CRC check code high byte
CRC_H	XXH	CRC check high low byte

Slave response:

Data Format	Data	Description
Address	01H	Device address: 1-99
Function code	06H	Signal return
Starting register H	00H	Starting register high byte
Starting register L	00H	Starting register low byte
Inquiry length H	00H	Inquiry length high byte
Inquiry length L	00H	Inquiry length low byte
CRC_L	89H	CRC check code high byte
CRC_H	CAH	CRC check high low byte

Command example

Host inquiry:

01 06 00 00 00 00 89 CA

Slave response:

01 06 00 00 00 00 89 CA

5.2.14 - SOE protection action query, Read only, “0CH custom protocol” code to read

Type	Byte	Data	Description
HEX	1	Protection start	01: Return; 02: Action
HEX	1	Arc trip	01: Return; 02: Action
HEX	1	Quick-break overcurrent protection	01: Return; 02: Action
HEX	1	Limited time overcurrent protection action	01: Return; 02: Action
HEX	1	Overcurrent protection action	01: Return; 02: Action
HEX	1	Zero sequence overcurrent action	01: Return; 02: Action
HEX	1	Overload protection action	01: Return; 02: Action
HEX	1	Failure protection action	01: Return; 02: Action
HEX	1	Smoke action	01: Return; 02: Action
HEX	1	Fire extinguishing control actions	01: Return; 02: Action

Example:

Host inquiry:

Data Format	Data	Description
Address	01H	Device address: 1-99
Function code	0CH	Read input registers
CRC_L	XXH	CRC check code high byte
CRC_H	XXH	CRC check high low byte

Slave response:

Data Format	Data	Description
Address	01H	Device address: 1-99
Function code	0CH	Read input registers
Data length	1FH	1F is protection action length, 0F is protection start length
Report attributes	04H	04: Action, 05: Alarm, 18: SOE
Serial number	02H	Protection action bit map: NO. (1# Arc trip)
Fixed format	01H	
Report type	17H	
Data width of this record	16H	
Fixed format	01H	
Status	02H	02: ON; 01: OFF
Second L	35H	50 s 741ms
Second H	C6H	
Minute	1BH	27 min
Hour	0EH	14:00 o'clock
	00H	
	20H	Message appears only when arc trip is activated.
	20H	Message appears only when arc trip is activated.
	20H	Message appears only when arc trip is activated.
	20H	Message appears only when arc trip is activated.
	20H	Message appears only when arc trip is activated.
	30H	Message appears only when arc trip is activated.
	30H	Message appears only when arc trip is activated.
	41H	Message appears only when arc trip is activated.
	20H	Message appears only when arc trip is activated.
	20H	Message appears only when arc trip is activated.
	20H	Message appears only when arc trip is activated.
	20H	Message appears only when arc trip is activated.
	20H	Message appears only when arc trip is activated.
	20H	Message appears only when arc trip is activated.
CRC_L	XXH	CRC check code high byte
CRC_H	XXH	CRC check high low byte

Command example**Host inquiry:**

01 0C 00 25

Slave response:

01 0C 0C 04 02 01 12 06 01 01 F5 B1 3B 0B 00 AF 82

5.2.15 - SOE alarm event query, Read only, “0CH custom protocol” code to read

Type	Byte	Data	Description
HEX	1	Rated value fails	01: Return; 02: Alarm
HEX	1	Parameter fail	01: Return; 02: Alarm
HEX	1	Device parameter fail	01: Return; 02: Alarm
HEX	1	FLASH fail	01: Return; 02: Alarm
HEX	1	AD fail	01: Return; 02: Alarm
HEX	1	Zero drift limit	01: Return; 02: Alarm
HEX	1	Communication initialization fail	01: Return; 02: Alarm
HEX	1	Output break down	01: Return; 02: Alarm
HEX	1	Control loop disconnection	01: Return; 02: Alarm
HEX	1	Spring discharged	01: Return; 02: Alarm
HEX	1	Arc protection alarm	01: Return; 02: Alarm
HEX	1	Zero sequence overcurrent alarm	01: Return; 02: Alarm
HEX	1	Overload alarm	01: Return; 02: Alarm
HEX	1	Smoke alarm	01: Return; 02: Alarm
HEX	1	Reserve	01: Return; 02: Alarm
HEX	1	Busbar temperature warning	01: Return; 02: Alarm
HEX	1	Busbar temperature warning	01: Return; 02: Alarm
HEX	1	Cable head temperature warning	01: Return; 02: Alarm
HEX	1	Upper contact temperature warning	01: Return; 02: Alarm
HEX	1	Lower contact temperature warning	01: Return; 02: Alarm
HEX	1	Busbar temperature alarm	01: Return; 02: Alarm
HEX	1	Cable head temperature alarm	01: Return; 02: Alarm
HEX	1	Upper contact temperature alarm	01: Return; 02: Alarm
HEX	1	Ultrasonic alarm	01: Return; 02: Alarm
HEX	1	TEV alarm	01: Return; 02: Alarm

Example:

Host inquiry:

Data Format	Data	Description
Address	01H	Device address: 1-99
Function code	0CH	Read input registers
CRC_L	XXH	CRC check code high byte
CRC_H	XXH	CRC check high low byte

Slave response:

Data Format	Data	Description
Address	01H	Device address
Function code	0CH	Read input registers
Data length	0FH	Total data length
Report attributes	05H	04: Action, 05: Alarm, 18: SOE
Serial number	0BH	Alarm event bit map: NO. (1# arc protection alarm)
Fixed format	01H	
Report type	12H	
Data width of this record	06H	
Fixed format	01H	
Status	02H	02: ON; 01: OFF
Second L	35H	50 s 741ms
Second H	C6H	
Minute	1BH	27 min
Hour	0EH	14:00 o'clock
	00H	
	08H	
	13H	
	01H	
CRC_L	XXH	CRC check code high byte
CRC_H	XXH	CRC check high low byte

Command example

Host inquiry:

01 0C 00 25

Slave response:

01 0C 0C 04 02 01 12 06 01 01 F5 B1 3B 0B 00 AF 82

5.2.16 - SOE DI signal query, Read only, "0CH custom protocol" code to read**Example:****Host inquiry:**

Data Format	Data	Description
Address	01H	Device address: 1-99
Function code	0CH	Read input registers
CRC_L	XXH	CRC check code high byte
CRC_H	XXH	CRC check high low byte

Slave response:

Data Format	Data	Description
Address	01H	Device address
Function code	0CH	Read input registers
Data length	16H	Total data length
Report attributes	18H	04: Action, 05: Alarm, 18: SOE
Serial number	02H	DI signal bit map: NO. (General alarm signal)
Fixed format	01H	
Report type	09H	
Data width of this record	06H	
Fixed format	01H	
Status	02H	02: ON; 01: OFF
Second L	56H	
Second H	B6H	46s 678ms
Minute	1CH	27 min
Hour	0FH	15 o'clock
	00H	
	08H	
	02H	
	01H	
	09H	
	01H	
	01H	
	02H	
	30H	
	30H	
	41H	
CRC_L	XXH	CRC check code high byte
CRC_H	XXH	CRC check high low byte

Command example

Host inquiry:

01 0C 00 25

Slave response:

01 0C 13 18 02 01 09 06 01 02 9C BB 01 0C 00 08 02 01 09 01 01 02 93 AB

5.2.17 - SOE query end command, Read only, “0CH custom protocol” code to read

Example:

Host inquiry:

Data Format	Data	Description
Address	01H	Device address: 1-99
Function code	0CH	Read input registers
CRC_L	XXH	CRC check code high byte
CRC_H	XXH	CRC check high low byte

Slave response:

Data Format	Data	Description
Address	01H	Device address: 1-99
Function code	0CH	Read input registers
Data length	03H	Total data length
CRC_L	XXH	CRC check code high byte
CRC_H	XXH	CRC check high low byte

Command example

Host inquiry:

01 0C 00 25

Slave response:

01 0C 03 65 01

5.2.18 - Restore factory settings, Write only, “13H custom protocol” code to write (not recommended for user)

Example:

Host inquiry:

Data Format	Data	Description
Address	01H	Device address
Function code	13H	Device time synchronization
Starting register H	00H	Starting register H
Starting register L	00H	Starting register L
Data length H	00H	Data length H
Data length L	00H	Data length L
CRC_L	XXH	CRC check code high byte
CRC_H	XXH	CRC check high low byte

Command example

Host inquiry:

01 13 00 00 00 00 84 09

No slave response

After sending, device automatically resets, so this report no slave response.

5.2.19 - Output test function, Write only, “05H custom protocol” code to write (not recommended for user)

Example:

Host inquiry:

Data Format	Data	Description
Address	01H	Device address
Function code	05H	Device time synchronization
Relay address H	00H	Starting register H
Relay address L	01H	Starting register L
	FFH	
	00H	
CRC_L	XXH	CRC check code high byte
CRC_H	XXH	CRC check high low byte

Slave response:

Data Format	Data	Description
Address	01H	Device address
Function code	05H	Device time synchronization
Relay address H	00H	Starting register H
Relay address L	01H	Starting register L
	FFH	
	00H	
CRC_L	XXH	CRC check code high byte
CRC_H	XXH	CRC check high low byte

Command example**1. DO 1 action: protection action signal**

Host inquiry: 01 05 00 01 FF 00 DD FA

Slave response: 01 05 00 01 FF 00 DD FA

2. DO 2 action: alarm signal

Host inquiry: 01 05 00 02 FF 00 2D FA

Slave response: 01 05 00 02 FF 00 2D FA

3. DO 3 action: protection trip

Host inquiry: 01 05 01 01 FF 00 DC 06

Slave response: 01 05 01 01 FF 00 DC 06

4. DO 4 action: failure protection trip

Host inquiry: 01 05 01 02 FF 00 2C 06

Slave response: 01 05 01 02 FF 00 2C 06

5. DO 5 action: fire control DO

Host inquiry: 01 05 02 01 FF 00 DC 42

Slave response: 01 05 02 01 FF 00 DC 42

6. DO 6 action: reserve

Host inquiry: 01 05 02 02 FF 00 2C 42

Slave response: 01 05 02 02 FF 00 2C 42

6. - SAFETY CONSIDERATIONS



All installation specification described at the previous chapters named:
INSTALLATION AND STARTUP, INSTALLATION MODES and SPECIFICATIONS.

Please note that with the instrument powered on, the terminals could be dangerous to touching and cover opening actions or elements removal may allow accessing dangerous parts. This instrument is factory-shipped at proper operation condition.

- ◆ The device must have a professional installation and maintenance.
- ◆ Any operation of the device, you must cut off the input signal and power.

7. - MAINTENANCE

The AFR-3 does not require any special maintenance. No adjustment, maintenance or repairing action should be done when the instrument is open and powered on, should those actions are essential, high-qualified operators must perform them.

Before any adjustment, replacement, maintenance or repairing operation is carried out, the instrument must be disconnected from any power supply source.

When any protection failure is suspected to exist, the instrument must be immediately put out of service. The instrument's design allows a quick replacement in case of any failure.

For any inquiry about the instrument performance or any failure,
contact to Blue Jay's technical service.

Blue Jay - After-sales service

E-mail: tech@cqbluejay.com