

PR SERIES DIGITAL MOTOR PROTECTION RELAY

PROTECTION AND CONTROL



Introduction

Digital motor protection relays, integral to motor systems, ensure motor reliability and safety by detecting internal faults (overcurrent, single-phase operation, grounding, bearing issues, and abnormal winding temperatures) and monitoring external conditions to prevent grid fluctuations and voltage surges from impacting the motor.

These relays safeguard motor system stability and power grid reliability by monitoring and controlling internal and external issues and isolating interference sources. It can effectively prevent motor damage and the spread of interference back into the power grid.



Main Features

- Data recording and analysis.
- Variety of protection functions.
- Fault alarm, automatic power off function.
- RS485 remote communication and control.
- Real time motor operating status monitoring.
- Flexible configuration, can customized for specific needs.

Application

- Automated industry.
- High voltage switchgear.
- Solar and wind energy systems.
- Power plant, power grid dispatching.
- Transmission towers and substations.

Measurement Function

	PR201	PR202	PR203	PR240	PR260
Protection function					
Max. start time	●	●	●	●	●
Overload	●	●	●	●	●
Increased safety motors overload	-	-	-	●	●
Over current-jam in starting	●	●	●	●	●
Over current-jam in running	-	●	●	●	●
Phase loss	●	●	●	●	●
Current imbalance	●	●	●	●	●
Over voltage	-	●	●	●	●
Under voltage	-	●	●	●	●
Under power	-	●	●	●	●
Ground fault	-	○	○	●	●
Over current-short	-	-	-	●	●
Over temperature	-	-	-	○	○
Abnormal frequency	-	-	-	●	●
Lead / Lag PF / Low power factor	-	-	-	●	●
Welded contactor	-	-	-	●	●
External fault	-	-	-	-	●
Internal failure	-	-	-	-	●
Restart	-	-	-	●	●
Start mode					
Protection only	●	●	●	●	●
Panel control start/stop	-	-	●	●	●
Forward and reverse start	-	-	●	●	●
Wye-delta transition	-	-	●	●	●
Autotransformer closed transition	-	-	-	●	●
Two-winding	-	-	●	●	●

●With this function ○Optional function -Without this function

PR200 SERIES ECONOMIC MOTOR PROTECTION RELAY

PROTECTION AND CONTROL



Introduction

PR200 motor protection relay comes in a small and economical appearance and designed to real time monitor three-phase power lines for abnormal conditions. can be used with motors below 690V/ 820A. optional RS485 communication port can upload monitoring data and alarm status to the remote control system.

PR200 provides various protection tripping to avoid motor failure. When PR200 senses that motor operating parameters reach preset alarm value, it will trigger DO port to warn of abnormal conditions; when abnormal parameters continue to accumulate to dangerous values, it will automatically trigger the release switch to close circuit.

Protection Function

IEEE / ANSI C37.2	Protection functions
48	Max. start time
49, 51	Overload
51	Increased safety motors overload
51R	Overcurrent level 1 - Jam
47	Phase loss
46	Current imbalance
50G/N, 51G/N	Ground fault
50	Over current level 2 - Short
32L	Underpower
38	Overtemperature
59	Overvoltage
27	Undervoltage
81U/81O	Abnormal frequency
55	Lead / Lag PF / Low power factor
74	Welded contactor

Main Features

- Built-in 2-channel relay.
- High accuracy sample calculation.
- Programmable analog output function.
- Optional RS485 communication interface.
- Free to configure each protection function.
- Wide range of power supply AC85-265V or AC80-450V.
- Have basic electrical parameter for user SCADA system.
- Build in sequence of event function, max 10 trip records.

Dimension

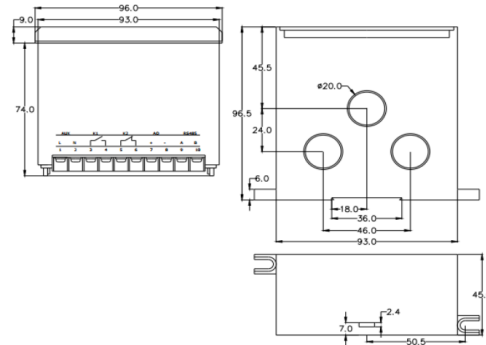

Split installation

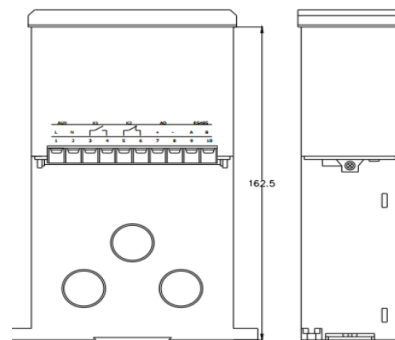

Panel mounting installation

PR240 SPLIT MOTOR PROTECTION RELAY

PROTECTION AND CONTROL



Introduction

PR240 motor protection relay can use with motors less than 690V/ 820A. It can realize a variety of control operation, such as measurement, self-diagnosis, maintenance management, field bus communication and other functions.

PR240 can real-time monitoring the scene signal, provide various protection trip to avoid motor failure. optional RS485 port can upload monitor data and alarm status to remote control system.

Protection Function

IEEE / ANSI C37.2	Protection functions
48	Max. start time
49, 51	Overload
51	Increased safety motors overload
51R	Overcurrent level 1 - Jam
47	Phase loss
46	Current imbalance
50G/N, 51G/N	Ground fault
50	Overcurrent level 2 - Short
32L	Underpower
38	Overtemperature
59	Overvoltage
27	Undervoltage
81U/81O	Abnormal frequency
55	Lead / Lag PF / Low power factor
74	Welded contactor

Main Features

- Dot matrix LCD display.
- Built-in 4-channels relay.
- Provide various start methods.
- User free to configure each protection function.
- Build in sequence of event function, max 100 trip records.
- With programmable analog output function.
- Optional RS-485 communication interface.

Dimension

Unit: mm

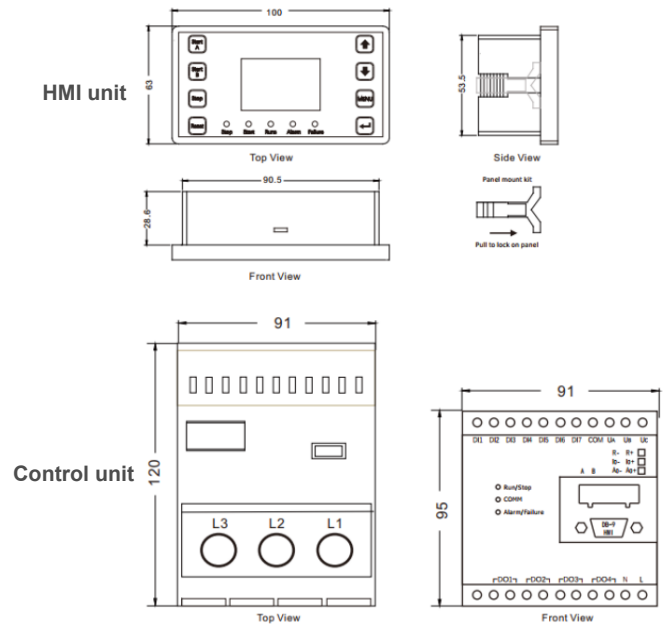

PR260 SERIES MODULAR MOTOR PROTECTION RELAY

PROTECTION AND CONTROL



Introduction

PR260 series motor protection relay is suitable for protecting and monitoring the low-voltage motors with rated voltage less than 690V and rated current up to 820A. It equipped with 7-channels switch monitoring, can be configured as needed. It supports Modbus-RTU communication bus and can transmit monitoring data and alarm status to the remote control system.

PR260 can real time monitor status of motor and detect various faults, such as abnormal start, overload, overcurrent, overheating, blocked rotor, phase loss, unbalance, under voltage, overvoltage, under power, underload, grounding or leakage.

Protection Function

IEEE / ANSI C37.2	Protection functions
48	Max. start time
49, 51	Overload
51	Increased safety motors overload
51R	Overcurrent level 1 - Jam
47	Phase loss
46	Current imbalance
50G/N, 51G/N	Ground fault
50	Overcurrent level 2 - Short
32L	Underpower
38	Overtemperature
59	Overvoltage
27	Undervoltage
81U/81O	Abnormal frequency
55	Lead / Lag PF / Low power factor
74	Welded contactor
86 or 94	External fault
	Data logging
	Wave capture

Main Features

- Record recent 99 trip records.
- Standard RS485 communication.
- Provide 4 digital outputs, and 7 digital inputs.
- Full power measurement, dot matrix LCD display.
- A control unit uses a CT connection with max 5A input.
- Multiple startup modes for different wiring applications.
- Suitable for motors under 0.66KV and any current range.
- Optional waveform capture function for easy fault tracing.
- Extra optional modular: PR-26C extra 2* RS485 or 2* Profibus-DP port.
- PR-265 extra programmable 11*DI and 6*DO.

Dimension

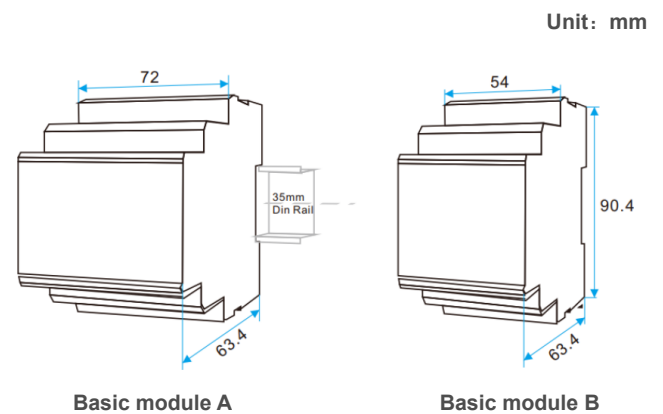

Technical Characteristics

	PR201	PR202	PR203	PR240	PR260
Electrical parameters					
Auxiliary power	85-265 VAC/DC				
Power consumption	<10 VA				
Insulation resistance	> 100 MΩ				
Alarm relay	5 A @ 250V AC, or 5 A @ 30V DC (NO contact)				
Working environment					
Motor rated voltage	AC 380V / AC 660V				
Motor rated current	0.5-820 A				
Working temperature	-10°C ~ +55°C				
Storage temperature	-25°C ~ +70°C				
Relative humidity	< 93% RH				
Altitude	No more than 3000 m				
Atmospheric conditions	Operating place must not have the explosive medium and contain Gases that corrode metals and damage insulating and conductive medium.				
Electrical test					
Electrostatic discharge	IEC 61000-4-2, Level III				
Electrical fast transient burst	IEC 61000-4-4, Level III				
Surge shock	IEC 61000-4-5, Level III				
Withstanding voltage	IEC 61010-1, AC2KV/1min Between power / input / output				
Other					
Digital output	2	2	3	4	4
Digital input	-	-	6	7	7
Analog output	-	1	-	1	1
RS485, Modbus-RTU	-	●	●	●	●
Profibus-DP	-	-	-	-	○
SOE	-	10	10	99	99
Record	-	-	-	●	●
Wave capture	-	-	-	-	●
Display	LED	LED	LCD	LED	LED

CT SELECTION TABLE

PROTECTION AND CONTROL



CT selection table

Motor rated power (Kw)	Rated current (A)	Default value
0.06	0.22	10A (CT306)
0.12	0.42	
0.37	1	
0.55	1.5	
0.75	2	
1.1	2.5	
2.2	5	
3	6.5	
5.5	11	100A (CT305)
7.5	14.8	
11	21	
15	28.5	
18.5	35	
22	42	
30	57	
37	69	
45	81	200A (CT304)
55	100	
75	135	
90	165	
110	200	

Rated power (Kw)	Rated current (A)	Connected ECT	Expand CT
132	240	CT306 Set Ext. CT 5A	500/5
160	285		
200	352		
220	420		
250	480		

- Notes:
- External protection CT selection guide, typical in 380V motor system
 - If motor rated current more than 200A, need use 5A external CT

External current transformer (ECT)

Motor rated power (Kw)	Rated current (A)	Default value
Measurement 100A-200A	10-100A	0-10A
Secondary to protector 100mA	100A/50mA	10A/5mA
Maximum cable size 30mm	20mm	9mm

Zero-sequence current transformer (ZCT)

Current range	Dimension (mm)								
	φ	A	B	C	D	E	F	G	H
16-100A	45	77	85	24	38	54	9	64	54
100-250A	80	112	122	28	56	80	14	89	80
250-400A	100	131	136	24	66	96	14	108	107
400-800A	150	200	209	28	100	145	16.5	184	177

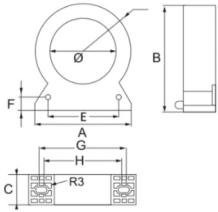

Current range	Dimension (mm)								
	A1	B1	A	B	C	D	E	F	G
0-63A	100	20	133	50	16	144	140	3	2.0
0-100A	100	25	133	60	24	154	143	9	2.5
0-225A	140	32	172	72	24	189	184	9	2.5
0-250A	180	32	212	72	24	229	224	9	2.5
0-400A	220	45	254	86	24	269	264	11	2.5
0-630A	260	45	294	86	24	309	304	11	2.5
0-1600A	300	45	334	86	24	349	344	11	2.5
0-4000A	420	45	454	86	24	469	464	11	2.5

