

MCM263T

Multi-Channel Energy Meter

User Manual



Version: 1.10

Revision: 2024.10

Read me

When you use MCM263T Multi-channel energy meter, be sure to read this user manual carefully, and be able to fully understand the implications, the correct guidance of operations in accordance with user manual, which will help you make better use of MCM263T Multi-channel energy meter, and help to solve various problems at the scene.

1. Before the meter turn on the power supply, be sure that the power supply within the provisions of the instrument;
2. When installation, the current input terminal must be non-open, voltage input terminals must be Non-short circuit;
3. Communication terminal (RS232/RS485 or Ethernet) is strictly prohibited to impose on high pressure;
4. Be sure the instrument wiring is consistent with the internal system settings;
5. When communicating with the PC, instrument communication parameters must be consistent with the PC.



- **Please read this user manual carefully**
- **Please save this document**

Directory

1.- SUMMARIZE	- 4 -
2.- FEATURES	- 5 -
2.1.- ELECTRICITY METERING	- 5 -
2.2.- MEASUREMENT FUNCTIONS DETAILS	- 6 -
3.- SPECIFICATIONS	- 8 -
4.- INSTALLATION AND START-UP	- 10 -
4.1.- INSTALLATION	- 10 -
4.2.- CONNECTION TERMINAL	- 14 -
4.3.- TYPICAL WIRING	- 15 -
5.- OPERATION MODE	- 17 -
6.- SCREEN DISPLAY	- 18 -
6.1.- OVERALL SCREEN	- 18 -
7.- SETUP PROCEDURE	- 19 -
7.1.- INPUT SIGNAL AND COMM PORT SETUP	- 20 -
7.2.- ALARM TRIG AND DO SETUP	- 21 -
7.2.1.- DO setting (Optional)	- 22 -
7.3.- SYSTEM AND RTC SETUP	- 25 -
7.4.- AO AND RECORD SETUP	- 25 -
8.- PULSE OUTPUT	- 26 -
9.- COMMUNICATION INTERFACE	- 27 -
9.1.- CONNECTION FOR THE RS485 BUS	- 27 -
9.2.- MODBUS © PROTOCOL	- 27 -
9.3.- REGISTER ADDRESS TABLE	- 28 -
9.4.- EXAMPLE	- 35 -
10.- SAFETY CONSIDERATIONS	- 36 -
11.- MAINTENANCE	- 36 -

1.- SUMMARIZE

MCM263T Multi-channel energy meter provides a compact and robust metering solution; it can enable reliable monitoring of commercial building electrical or industry loads with a low installation cost-per-point by combining sub-metering.

The device performs real-time metering, measures energy consumption and generation, multi-tariff time-of-use (TOU) and monitors power quality for advanced communications options including Modbus via RS485, Ethernet interface, and various combination options of I/O communications provide for extensive reliable data exchange.

Max 18 channel circuits for single-phase circuits(MCM261T) or 6 channel for three-phase circuits (MCM263T). Multiple units can be connected together to meter unlimited number of circuits.

The versatility of MCM263T meters are ideal for multi-tenant or departmental metering applications within office towers, condominiums, apartment buildings, shopping centers and other multi-user environments.

APPLICATIONS

- Manufacturing plants, industrial parks and processing workshops;
- Office buildings, commercial centers and shopping malls;
- Residential communities, apartment buildings;
- Schools, hospitals and government buildings;
- Transportation infrastructure, airports, train stations and subway stations;
- Data centers such as server rooms, network operation centers.

2.- FEATURES

2.1.- ELECTRICITY METERING

MCM263T has two models:

MCM263T Three phase measurement, max connect 6 channel three phase circuit.

MCM261T Single phase measurement, max connect 18 channel single phase circuit.

MCM delivers the following parameters listed by RS485 ports, have High-definition screen to show various parameters and status of meter on each page jump, work with 4 buttons can do configuration of device. For more details, please refer to the subsequent chapter.

Function overall

	Function	Parameter	
Real-time Parameter	Voltage	Ua, Ub, Uc / Uab, Ubc, Uca	●
	Current	Per channel / Per phase	●
	Power	Per channel / Per phase	●
	Reactive Power	Per channel / Per phase	●
	Apparent Power	Per channel / Per phase	●
	Power Factor	Per channel / Per phase	●
	Frequency	Per channel / Per phase	●
Energy	Active Energy +	Per channel	●
	Reactive Energy +	Per channel	●
	Active Energy -	Per channel	●
	Reactive Energy -	Per channel	●
	TOU	4 Tariffs, 12 Segment	○
Power Quality	THD	UTHD, UTOHD, UTEHD, UTHFF, UCF ITHD, ITOHD, ITEHD, IKF	○
	Individual Harmonic	2nd-31st	○
	Voltage Unbalance	/	○
	Current Unbalance	/	○
	Power Demand	Last three month demand record	○
	Voltage Deviation	/	○
Alarming	Virtual alarm	5 Alarm trig	○
I/O	1PO	Default 5000imp/kWh VCC<48V, Iz<50mA	○
	2DO	5A@250Vac / 5A@30Vdc	○
	6DI	Ri<500Ω open, Ri>100kΩ Closed	○
Communication	RS485	RS485, Modbus-RTU	●
	Ethernet	Ethernet, Modbus-TCP,IP	○

Notes: "●" for Standard functions; "○" for Optional functions;

Tel:+0086-023-67628702

Email:tech@cqbluejay.com

www.cqbluejay.com

Add: 1802, Building 2, No.88, Jianxin East Road, Chongqing, 400020, China

2.2.- Measurement functions details

- Real-time electrical parameter measurement

Voltage: Line Voltage (L-L); Phase Voltage(L-N)

Current: Current per channel (A)

Power and Power Factor: Total power Reactive Power(kW), Apparent Power (VA), Power Factor and for per channel

Frequency: System Frequency (Hz)

- Demand

Total Power, Reactive Power, Apparent Power per channel

- Energy function

Energy (kWh) measurement meeting international standards, accuracy is Class 0.5.

Optional Time of Use (TOU): 12 segments, 4 Tariffs record, max three-month data for each channel.

- Power quality analysis

Optional power quality parameters such as voltage and current THD, Odd harmonic distortion (Total Odd HD), even harmonic distortion (Total Even HD), 2 ~ 31 times the harmonic content, Current K-factor (KF), crest factor (CF), telephone interference factor (THFF), voltage and current unbalance etc.

- Over/Under limit alarming

Users can select parameters and set t thresholds. An alarm will be triggered when the threshold reached. At the same time, sound and light signals could be sent out via relay output. The time and reason of an alarm event will be recorded.

- I/O option

Standard 1 channels output ports provide energy (kWh) pulse output and time pulse output; optional 6 channels digital inputs (DI) provide pulse counting from water, electricity and gas meter, and monitor switch status; optional 2 channels relay outputs (DO) react upon alarming conditions.

I/O modules can be combined matching.

- Communication and network

Supports RS485 communication open protocol: Modbus RTU; and Ethernet/ TCP, IP is optional.

Note:

Not all MCM263T have the complete measurement parameters, Without the parameter, the corresponding part of the menu is not valid.

3.- SPECIFICATIONS

- Working power

AC/DC 90-240V, 45-65Hz, or DC 20-60V (Optional)

Maximum power consumption 6W

- Input

Current: Rated 5A (Optional 1A)

Voltage: Rated 0~480V (CATIII-300V)

Frequency: 45-65Hz

Current overload : 1.2 times rated continuous; 5 seconds for 10 times of the rated

Voltage overload : 30 seconds for 2 times of the rated

- Accuracy standard

Parameter	Accuracy	A phase	B phase	C phase	All
Voltage	0.2	V1	V2	V3	
Current	0.2	A1	A2	A3	
Active Power	0.5	W1	W2	W3	W
Reactive Power	0.5	var1	var2	var3	var
Apparent power	0.5	VA1	VA2	VA3	VA
Power Factor	0.5	PF1	PF2	PF3	PF
Active Energy	1				Wh
Reactive Energy	2				varh
Frequency	0.1				Hz

- EMC test

Parameter	Standard	Test voltage
Discharge immunity test	IEC61000-4-2 level 4	8kV
Surge (Shock) immunity test	IEC61000-4-5 level 4	Common test voltage 4kV
Fast transient burst immunity test	IEC61000-4-4 level 3	Input 1kV; Power supply 2kV

- Reference standard

Basic electricity IEC 61557-12:2018

Active energy IEC 62053-21:2020

Reactive energy IEC 62053-23:2020

- Dielectric strength

IEC/EN 61010-1:2012

2kV AC RMS 1 minute, between input / output / case / power supply

- Work environment

Temperature: -20°C ~ +60°C

Humidity: RH 20%~95% (No condensation)

- Storage environment

Temperature: -25°C ~+70°C

Humidity: RH 20%~95% (No condensation)

4.- INSTALLATION AND START-UP



The manual you hold in your hand contains information and warnings that the user should respect in order to guarantee a proper operation of all the instrument functions and keep it in safety conditions. The instrument must not be powered on and used until its definitive assembly is on the cabinet's door.

If the instrument is not used as manufacturer's specifications, the protection of the instrument will be damaged.

When any protection failure is suspected to exist (for example, it presents external visible damages), the instrument must be immediately powered off. In this case contact a qualified service representative.

4.1.- Installation

Mounting

MCM263T is to be mounted on 35mm Din-rail.

- Step-1** Fasten a section of 35 mm DIN rail (at least 8 inches long) to the mounting surface with appropriate hardware.
- Step-2** Use the white plastic clips on the back of the MCM263T meter to clip the meter onto the rail.
- Step-3** Verify that the meter is securely fastened to the wall.

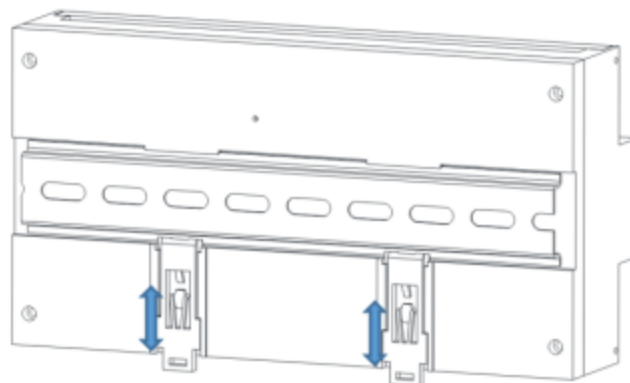

There have two flaps cover, can sealed by lead wire to protect unauthorized access terminal block, to achieve physical anti-theft function. Also capable of completely shielding the terminal head to prevent accident electrical shock.

Warning that with the instrument powered on, the terminals could be dangerous to touch and cover opening actions or elements removal may allow accessing dangerous parts.

Tel:+0086-023-67628702

Email:tech@cqbluejay.com

www.cqbluejay.com

Add: 1802, Building 2, No.88, Jianxin East Road, Chongqing, 400020, China

Therefore, the instrument must not be used or operation key button until this is completely installed and closed the cover.

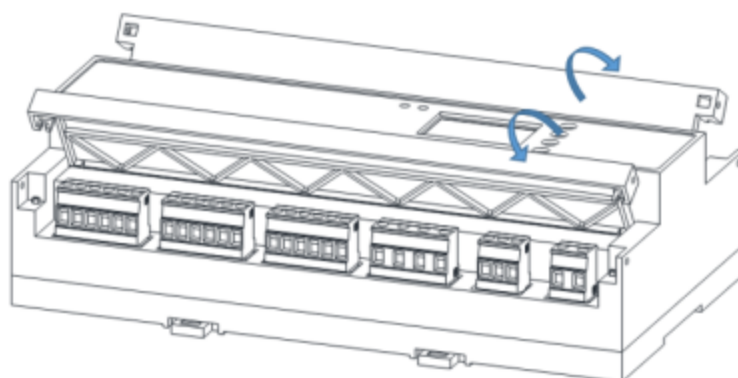

Dimension

W*H*D: 180×110mm×66mm

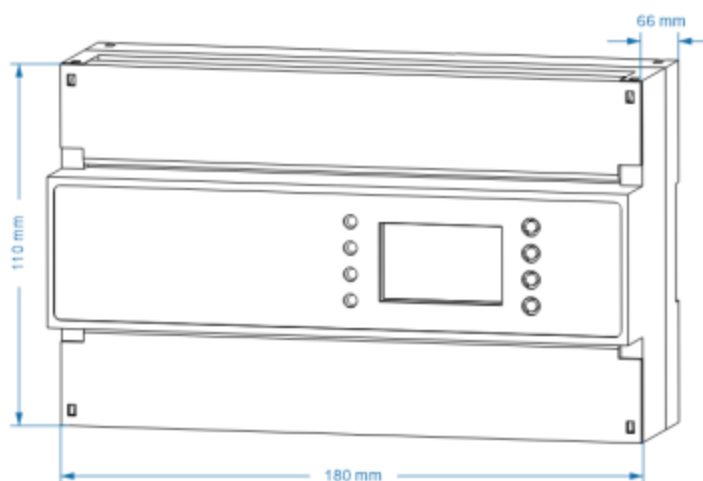

Notes:

Input signal: MCM263T using a separate acquisition calculate for each measurement channel, to ensure consistent in use, for different load forms, it's a variety of connection mode. Access wire shall be met 2.5 square mm.

A. Voltage input

Input voltage should not exceed the rated input voltage products 450V, Otherwise, you should use external VT. Suggest 1A fuse be installed in the voltage input side.

B. Current Input

Standard input current is 5A or 1A, if greater than 5A/1A should use external CT. When the CT is connected with other meters, make sure wiring methods be used in series.

Warning: Forbid to install a CT on the live feeder wire with open secondary leads. This can be extremely dangerous!!

Before remove the current input connection, must be sure to disconnect the primary circuit or shorted secondary circuit of CT.

C. Sequence of wire

Warning: Please make sure that the input voltage and current corresponding to the same phase, sequence, and the same direction; Otherwise, the Values and symbols will be wrong! (Power and Energy)

Always observe the physical orientation of CT (P1 - P2) when installing on the feeder wire. Always pay attention to wiring polarity and phasing when terminating the CT leads to the MCM263T. S1 connect to Ix*, S2 connect to Ix.

The input network configuration of instrument depends on the CT number of the system:

in the condition of 2 CT, select the three-phase, three-lines two components;
in the condition of 3 CT, select the three-phase, four-lines three component mode.

Instrument connection mode, set of the instrument (programming input network NET) should be the same load wiring as measured wiring. Otherwise, the measurement instrument will lead to incorrect voltage or power.

In three-phase 3 wire mode, measurement and shows the line voltage;
In three-phase 4 wire mode, measurement and shows the phase voltage and line voltage both.

Auxiliary power

MCM263T with universal (AC / DC) power input, if not for a special statement, we provide the 90-240 AC/DC power interface for standard products, please ensure that the auxiliary power can match with meter to prevent unexpected damage.

- A. Suggest install 1A fuse in the fire line side.
- B. For the areas with poor power quality, suggest install lightning surge suppressor and rapid burst suppressor to prevent lightning strikes.

4.2.- Connection Terminal

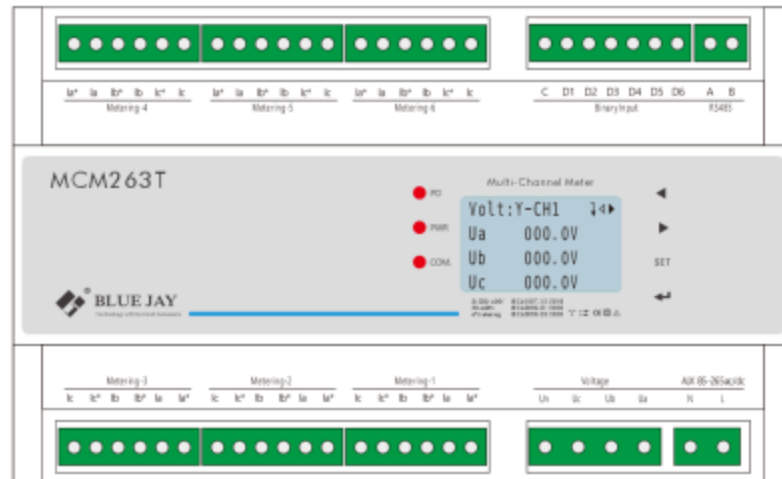

Note:

- Each Metering can implement of 1-channel of three-phase wiring and 3-channels of single-phase wiring.
- The terminal pin definition may change depends on customer order; please refer to the label on the meter!
- If do not optional DO/DI, no internal circuit be install, the terminal block is disable.
- Typical wiring: 1P2W (max 18 channels) and 3P4W & 3P3W (max 6 channels).

4.3.- Typical wiring

1P2W (max 18 channels)

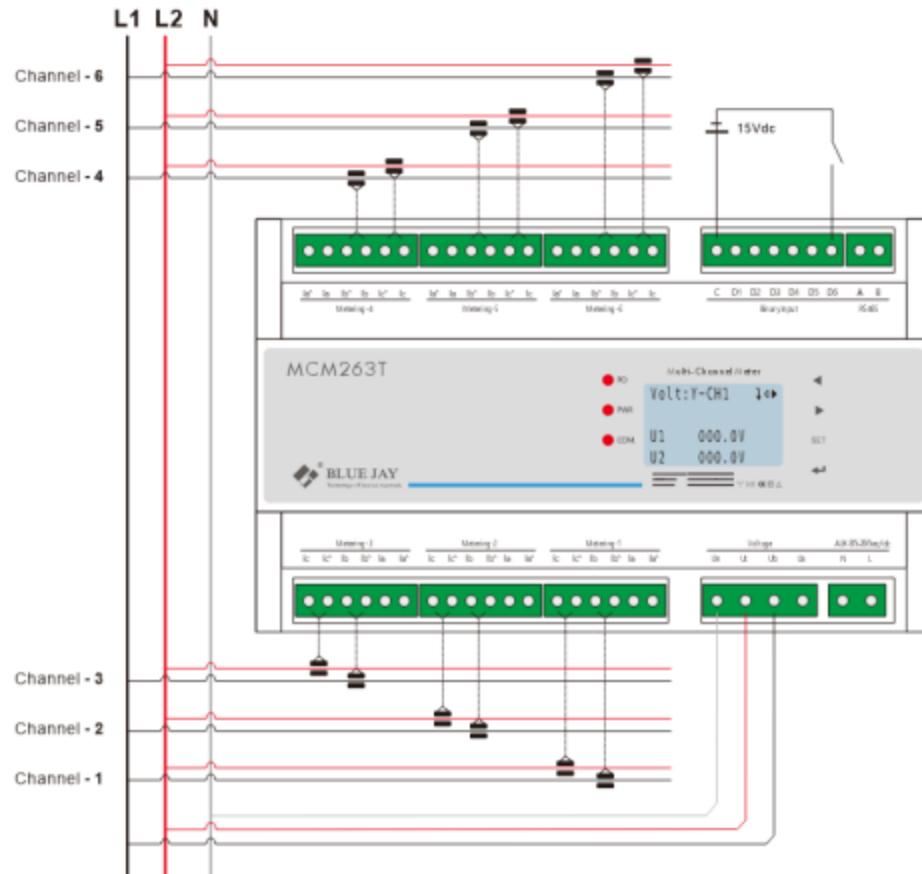

Notes:

1. DI port internal feed 15VDC power, Common terminal is positive pin.
2. AUX can connect from feeder Busbar.

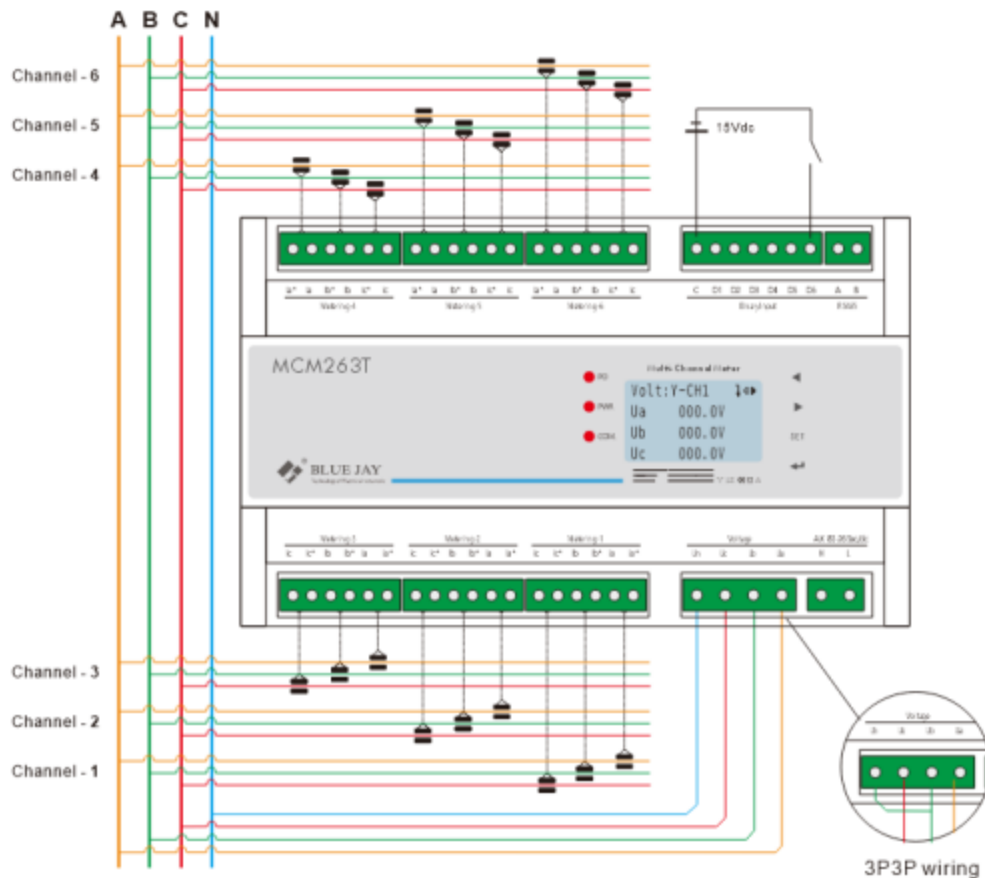
3P3W/3P4W (max 6 channels)

Note:

In 3P3W wiring, Ub and Un need short external as drawing, or the display voltage will wrong.





WARNINGS!

If power = -0.01 is shown for any of the phases and voltage and current are not zero for this phase, check out following points:

- Assure that A, B and C phases coincide in voltage and current.
- Correct polarity? Reverse the current transformer placed at this phase.

5.- OPERATION MODE

When the MCM263T and display unit are powered up, the entire symbol will be on, and the meter starts to self- test. After some seconds, the meter is ready for operation and shows one of the available screens.

Button	In Monitor Screen	In Config sub-menu	In Parameter Setup
	Screen will change to channel 1-6	Move cursor up and down to select function	Move setting cursor to left
	Screen will move to next page		Scroll selection number 0 ~ 9
	Call out password screen	Exit & roll back to up level menu.	
	Change to P-P Volt screen or Call out RTC screen	Confirm values & Entry or jump to down level menu	

Note: In Setup menu, if change the setting value, press  for exit menu, device will call out confirm screen ask "SAVE".

Then press  *exit without saving.*

press  *save and exit.*

6.- SCREEN DISPLAY

6.1.- OVERALL SCREEN

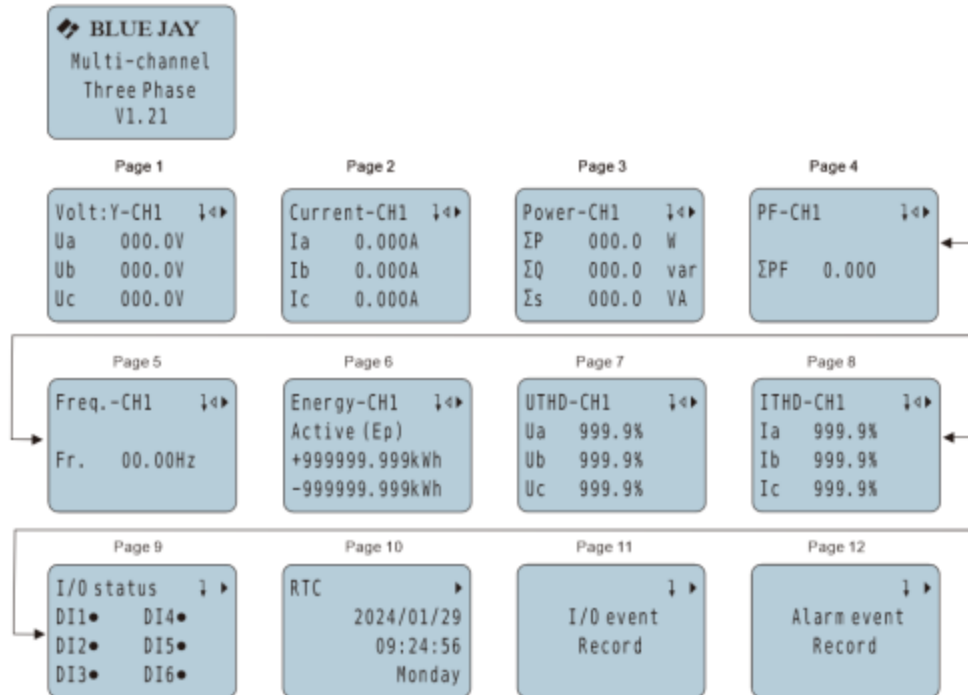

Notes:

Pages marked with ↓ indicate that this page has a sub-menu.

The above picture displays all function information. If this meter does not have the certain function, it can be ignored.

6.1.1.- Screen detailed instructions

Page No.	Description	Page No.	Description
Page 1	System voltage	Page 7	Voltage total harmonic distortion
Page 2	Primary current	Page 8	Current total harmonic distortion
Page 3	Power information	Page 9	DI/DO status
Page 4	Power factor	Page 10	Real time clock
Page 5	System frequency	Page 11	DI/DI event record
Page 6	Energy record	Page 12	Alarm event record

7.- SETUP PROCEDURE

The SETUP procedure of the MCM263T is performed by means of several SETUP options. There has a password (**default 0001**) to protect unexpectedly enter the Setup menu. Once into the Setup menu, use the keyboard to select different options and enter required variables:

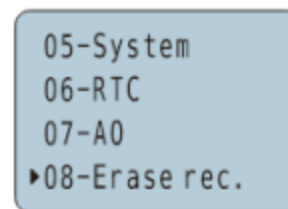
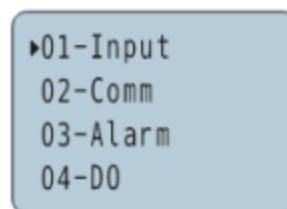
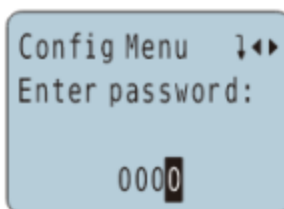
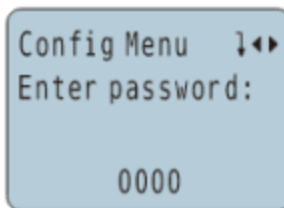

Input	Basic settings of signal access	System	System settings
Comm	Communication port setting	RTC	Real-time clock setting
Alarm	Alarm trig threshold setting	AO	Analog output port setting
DO	Digital relay output port setting	Erase rec.	Erase record setting

Note:

In root menu there have 8 sub-menus for different parameter setup, if your MCM263T do not have related function, the Setup page will disable, can skip the sub-menu.

7.1.- Input signal and comm. port setup

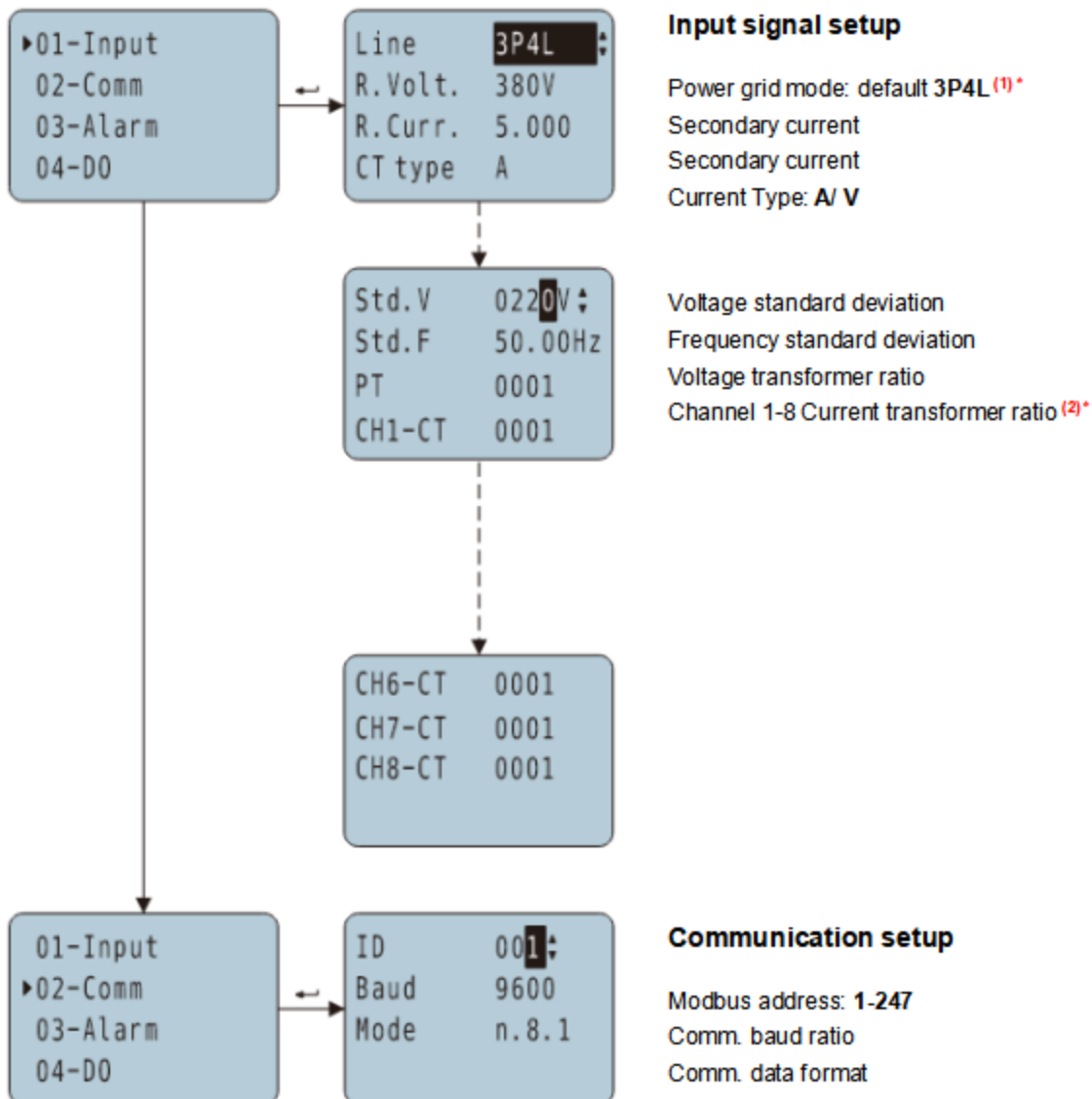

Notes:

1. Wiring method: Three-phases and single-phase versions can be configured differently: default 3P4L, optional: 3P3L3CT, 3P3L2CT; 1P2L, 2P3L. Current transformer default 5A, optional 100mA.
2. Blue Jay calibrates meter under 380V range, and high-quality linearity performance ensures that the meter can accurately measure in the lower voltage range. That can be compatible with 120V, 220V, 230V, 240V, 277V system. If need to use in different voltage scale or different types CT, please contact our sales team for more details.

7.2.- Alarm trig and DO setup

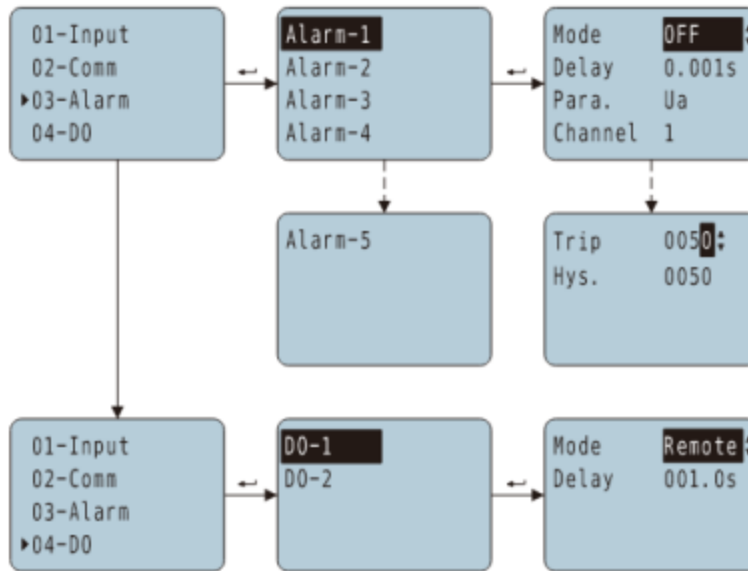

Alarm trig threshold setting

Alarm mode: OFF, Rising, Falling

Delay timer of the trig

Parameter be triggered

Channel value: 1-X,0 ,0 is used for DI setting

Trip value

Hysteresis value: default 0050

Digital output setup

DO working mode: remote, alarm1-5

Delay timer of the trig

Detail refer to [Chapter 7.2.1](#)

7.2.1.- DO setting (Optional)

MCM263T optional physical DO port, if not choose this port, this chapter is invalid.

The physical DO relay standard is 5A 250VAC / 5A 30VDC.

Sub-setting	Settings value	Definition
Mode	[Remote] / [Alarm-X] / [OFF]	[Remote] - DO act by RS-485 control command [Alarm-X] - DO act when Alarm-X be triggered [OFF] – DO always closed, cannot control Default Remote
Time	0.0~999.9s	000.0 - Level type signal, contact coil will close when triggered. 000.1~999.9 - Pulse type signal, value for width. Contact coil will close in the pulse width time, then release. Note: In [Alarm-X] the value setting is valid Default 0.1s
Parameter	Ua ,Ub,Uc,Uab,Ubc,Uac,UX-x Ia,Ib,Ic,Pa,Pb,Pc,PΣ Qa,Qb,Qc,QΣ Sa,Sb,Sc,SΣ DI1,DI2,DI3,DI4,DI5,DI6L	Parameter be triggered. Notes: Uabc, Iabc mean any value in phase Ps, Qs, Ss mean total value in three phase Not all value above in screen, depends on sub-mode of MCM263T
Value	0~9999	Trig threshold, value related to secondary side, units. Voltage - 0.1V Current - 0.001A Active power - 0.1W Reactive power - 0.1VAR Power factor - 0.001 Frequency- 0.01HZ Default is 5500
Hysteresis*	0~9999	When the measurement parameter falls back lower / over this exceed value, the alarm will be released. Default is 0050

***Remote mode operation**

In [Remote] mode, user can use function code 05 to trig single relay, device RS-485 port follow MODBUS-RTU protocol, command as following:

Host inquiry:

01	05	00 01	FF 00	DD FA
Address	Code	No.1 Relay register	Relay value (FF00:close; 0000: open)	CRC

Slave response:

01	05	00 01	FF 00	DD FA
Address	Code	No.1 Relay register	Relay value (FF00:close; 0000: open)	CRC

*** Delay & Hysteresis value**

Example in upper limit alarm of A phase voltage:

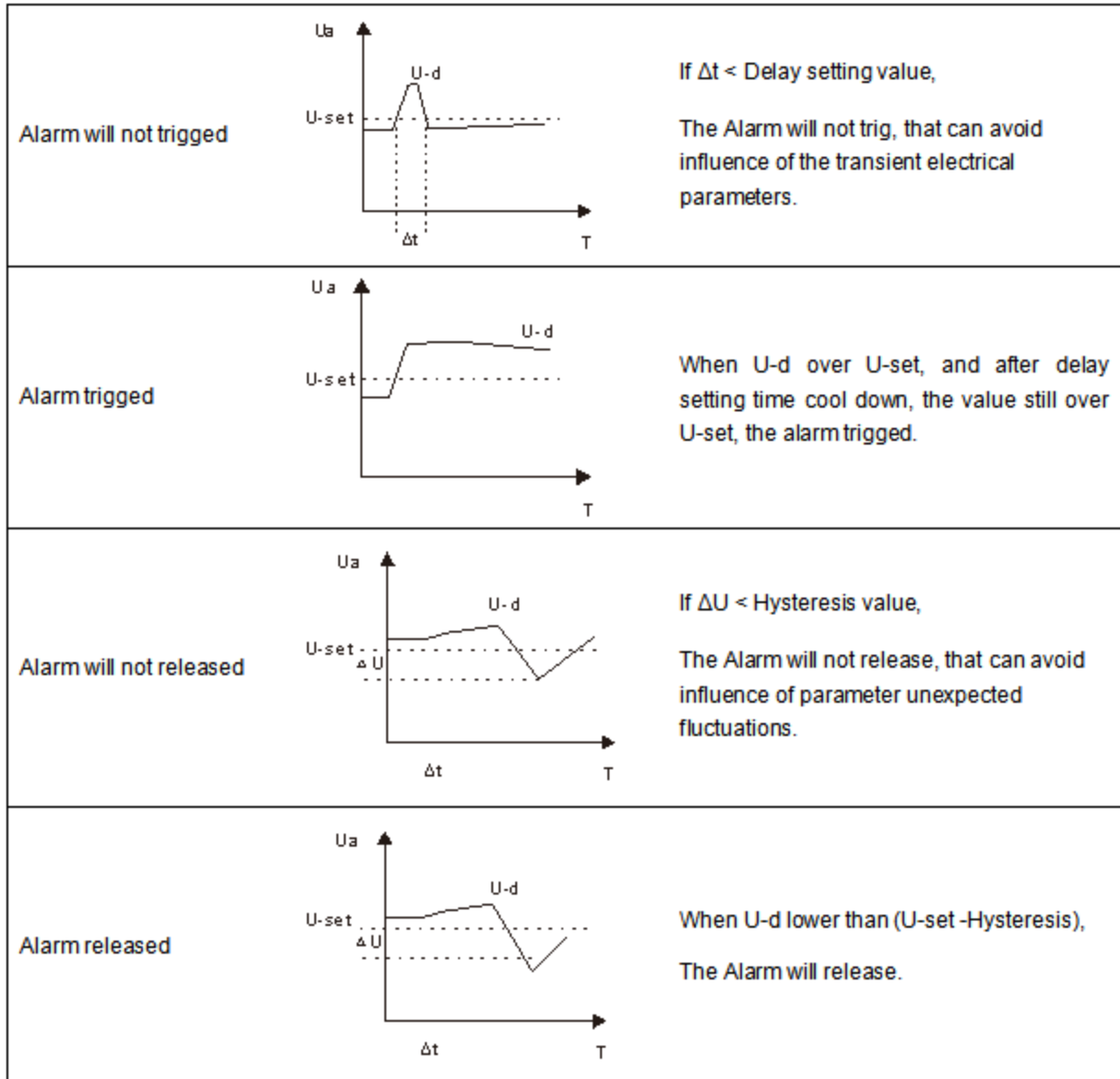
U-d mean detected **U_a**
U-set mean Alarm value of A phase

7.3.- System and RTC setup

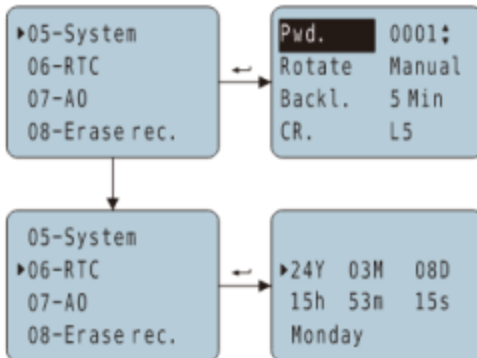

System parameter setup

Password: default 0001
 Page scroll method: manual,1-9sec
 Duration of LCD backlight: ON,0-10min
 Color contrast: L1-9

Real-time clock set up

7.4.- AO and record setup

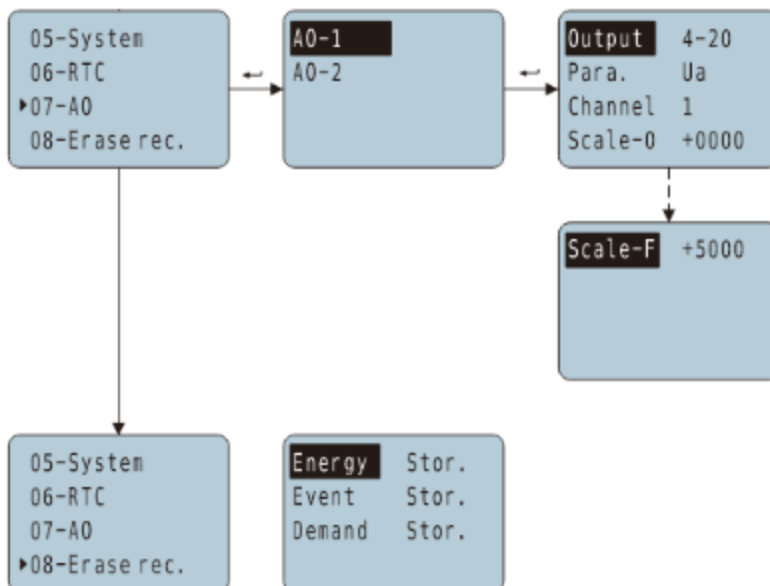

Analog output setup

Analog output signal range
 Analog output signal parameter
 Channel value: 1-X,0 ,0 is used for DI setting.
 Zero-scale value
 Full-scale value

Erase record setting

Erase energy records
 Erase event records
 Erase demand records

(Note: optional storage or erase, need to save after setting.)

8.- PULSE OUTPUT

MCM263T provides 1* pulse output for the active energy.

The host / PLC / DI module can cumulative the data of both the active and reactive power energy sent by the pulse from opt coupler relay.

1). Electrical specification: voltage $VCC \leq 48V$, $I_z \leq 50mA$.

2). Pulse: 5000 imp / kWh, pulse up to 80ms.

This means: When the device detects 1 kWh, the port will generate 5000 pulse

Note:

1 kWh energy is for secondary side energy data, if there have PT and CT accessed; primary side energy data is "1 kWh \times PT ratio \times CT ratio".

Voltage (V)	Current (A)	Pulse constant (imp / kWh)
380 or 220	5	5000
	1	20000
100	5	20000
	1	80000

Example: In measure time "T", the received total pulse is "N",
 Primary side input of voltage is 10Kv
 Primary side input of current is 400A.
 Secondary side measurement range is 100V and 5A.

In the time "T", energy accumulated is: $N / 20000 \times 100 \times 80$

9.- COMMUNICATION INTERFACE

9.1.- Connection for the RS485 BUS

The composition of the RS-485 cabling must be carried out with a meshed screen cable (minimum 3 wire), diameter of not less than 0.5mm², with a maximum distance of 1,200 meters between the MCM263T and the master unit. This Bus may connect a maximum of 247 MCM263T.

Notes:

1. Full range of MCM263T meter RS485 PIN number is 58,59,60
2. Due to product modifications or custom requirements, the interface pin place may be change.
For details, please refer to product label on the rear board.

9.2.- MODBUS © protocol

Modbus RTU Frame Format:

Address code	1 BYTE	<i>Slave device address 1-247</i>
Function code	1 BYTE	<i>Indicates the function codes like read coils / inputs</i>
Data code	4 BYTE	<i>Starting address, high byte Starting address, low byte Number of registers, high byte Number of registers, low byte</i>
Error Check code	2 BYTE	<i>Cyclical Redundancy Check (CRC)</i>

MODBUS FUNCTIONS

Code	Meaning	Description
FUNCTION 03	Reading of n Words	<i>This function permits to read all the electrical parameters of the BJ...series.</i>
FUNCTION 06	Write of Registers	<i>Write value in to the relevant register</i>

Notes:

Blue Jay Default disable the write function, if want change configuration via RS485, please contact Blue Jay Sales Team before your order.

9.3.- Register address table

9.3.1.- Basic power data-primary side

Address	Data	Byte mode		Instruction
0x00	Ua	float	2	Channel_1 Phase to Line Voltage, Unit: V
0x02	Ub	float	2	
0x04	Uc	float	2	
0x06	Uab	float	2	Channel_1 Phase to Phase Voltage, Unit: V
0x08	Ubc	float	2	
0x0a	Uca	float	2	
0x0c	Ia	float	2	Channel_1 Three phase Current, Unit: A
0x0e	Ib	float	2	
0x10	Ic	float	2	
0x12	Pa	float	2	Channel_1 Individual phase active power, Unit: kW
0x14	Pb	float	2	
0x16	Pc	float	2	
0x18	$P\Sigma$	float	2	Channel_1 Total active power, Unit: kW
0x1a	Qa	float	2	Channel_1 Individual phase reactive power, Unit: kVar
0x1c	Qb	float	2	
0x1e	Qc	float	2	
0x20	$Q\Sigma$	float	2	Channel_1 Total reactive power, Unit: kVar
0x22	Sa	float	2	Channel_1 Individual apparent power, Unit: kVA
0x24	Sb	float	2	
0x26	Sc	float	2	
0x28	$S\Sigma$	float	2	Channel_1 Total apparent power, Unit: kVA
0x2a	PFa	float	2	Channel_1 Individual power factor, 0~1.000
0x2c	PFb	float	2	
0x2e	PFc	float	2	
0x30	$PF\Sigma$	float	2	Channel_1 Total power factor, 0~1.000
0x32	FR	float	2	Channel_1 Frequency, Unit:0.01Hz
0x34	Ep+	float	2	Channel_1 Positive active energy, Unit: kWh
0x36	Ep-	float	2	Channel_1 Negative active energy, Unit: kWh
0x38	Eq+	float	2	Channel_1 Positive reactive power, Unit: kVarh
0x3a	Eq-	float	2	Channel_1 Negative reactive power, Unit: kVarh
0x64~ 0x9e	/	float		Channel_2 Electrical data

0xc8~ 0x102	/	float	Channel_3 Electrical data
0x12c~ 0x166	/	float	Channel_4 Electrical data
0x190~ 0x1ca	/	float	Channel_5 Electrical data
0x1f4~ 0x22e	/	float	Channel_6 Electrical data

NOTE: Float data follow IEEE754, float low bit first, high bit next. (CD AB)

9.3.2.- Basic power data-secondary side

Address	Data	Byte mode		Instruction
0x258	Ua	int	1	Channel_1 Phase to Line Voltage, Unit: 0.1V
0x259	Ub	int	1	
0x25a	Uc	int	1	
0x25b	Uab	int	1	Channel_1 Phase to Phase Voltage, Unit: 0.1V
0x25c	Ubc	int	1	
0x25d	Uca	int	1	
0x25e	Ia	int	1	Channel_1 Three phase Current, Unit: 0.001A
0x25f	Ib	int	1	
0x260	Ic	int	1	
0x261	Pa	int	1	Channel_1 Individual phase active power, Unit: W
0x262	Pb	int	1	
0x263	Pc	int	1	
0x264	P Σ	int	1	Channel_1 Total active power, Unit: W
0x265	Qa	int	1	Channel_1 Individual phase reactive power, Unit: Var
0x266	Qb	int	1	
0x267	Qc	int	1	
0x268	Q Σ	int	1	Channel_1 Total reactive power, Unit: Var
0x269	Sa	int	1	Channel_1 Individual phase apparent power, Unit: VA
0x26a	Sb	int	1	
0x26b	Sc	int	1	
0x26c	S Σ	int	1	Channel_1 Total apparent power, Unit: VA
0x26d	PFa	int	1	Channel_1 Individual power factor, 0~1.000
0x26e	PFb	int	1	
0x26f	PFc	int	1	
0x270	PF Σ	int	1	Channel_1 Total power factor, 0~1.000
0x271	FR	int	1	Channel_1 Frequency, Unit:0.01Hz
0x272	Ep+	int	2	Channel_1 Positive active energy,

Tel:+0086-023-67628702

Email:tech@cqbluejay.com

www.cqbluejay.com

Add: 1802, Building 2, No.88, Jianxin East Road, Chongqing, 400020, China

				Unit: Wh
0x273	Ep-	int	2	Channel_1 Negative active energy, Unit: Wh
0x274	Eq+	int	2	Channel_1 Positive reactive power, Unit:Varh
0x275	Eq-	int	2	Channel_1 Negative reactive power, unit: Varh
0x2bc~ 0x2d9	/	int	/	Channel_2 electrical data
0x320~ 0x33d	/	int	/	Channel_3 electrical data
0x384~ 0x3a1	/	int	/	Channel_4 electrical data
0x3e8~ 0x405	/	int	/	Channel_5 electrical data
0x44c~ 0x469	/	int	/	Channel_6 electrical data

9.3.3.- Meter status data

Address	Data	Byte mode		Instruction
0x4b0	DO	int	1	Digital output: Bit 0~1 show channel 1and channel 2 status 0 for open, 1 for closed
0x4b1	DI	int	1	Digital input: Bit 0~5 show channel 1 to channel 6 status 0 for open, 1 for closed

9.3.4.- R/W parameters

Note:

If do not clear the MCM263T communication parameter, please shot the "RESET" pin and hole 5sec for recover the communication to default setting.

Default setting:

Address: 1

Baud ratio: 9600

Data format: n.8.1

Address	Item	Byte mode		Description
0x4ba	Port_1 COMM Address	Int	1	Range: 1-247
0x4bb	Port_1 Baud Ratio	Int	1	0: 2400 1: 4800 2: 9600 3: 19200
0x4bc	Port_1 Data Format	Int	1	0: n.8.1 1: o.8.1 2: e.8.1 3: n.8.2
0x4bd	Port_2 COMM Address (for DISPLAY unit)	Int	1	Disallowed configuration when work with DISPLAY unit! or will may display error; If done some change, please shot the "RESET" for recover the fault setting
0x4be	Port_2 Baud Ratio (for DISPLAY unit)	Int	1	
0x4bf	Port_2 Data format (for DISPLAY unit)	Int	1	
0x4c0~ 0x4c3	/	Int	1	reversed
0x4c4	DO1 Mode	Int	1	0: Remote 1: Alarm 2: OFF
0x4c5	DO1 Act delay	Int	1	Alarm mode: 0.0-999.9sec Remote mode: 0: Level mode Other value: 0.1-999.9sec (Pulse width)
0x4c6	DO1 Alarm data	Int	1	0: UA upper alarm 1: UB upper alarm 2: UC upper alarm 3: UAB upper alarm 4: UBC upper alarm 5: UCA upper alarm 6: UA/UB/UC upper alarm 7: channel_1 IA upper alarm 8: channel_1 IB upper alarm 9: channel_1 IC upper alarm 10: channel_2 IA upper alarm 11: channel_2 IB upper alarm

				12: channel_2 IC upper alarm 13: channel_3 IA upper alarm 14: channel_3 IB upper alarm 15: channel_3 IC upper alarm 16: channel_4 IA upper alarm 17: channel_4 IB upper alarm 18: channel_4 IC upper alarm 19: channel_5 IA upper alarm 20: channel_5 IB upper alarm 21: channel_5 IC upper alarm 22: channel_6 IA upper alarm 23: channel_6 IB upper alarm 24: channel_6 IC upper alarm 25: current upper alarm for any channel 26: PA upper alarm 27: PB upper alarm 28: PC upper alarm 29: total active power upper alarm 30: QA upper alarm 31: QB upper alarm 32: QC upper alarm 33: total reactive power upper alarm 34: SA upper alarm 35: SB upper alarm 36: SC upper alarm 37: total apparent power upper alarm 38: total power factor upper alarm 39: frequency upper alarm 40: DI1 close alarm 41: DI2 close alarm 42: DI3 close alarm 43: DI4 close alarm 44: DI5 close alarm 45: DI6 close alarm 46: UA lower alarm 47: UB lower alarm 48: UC lower alarm 49: UAB lower alarm 50: UBC lower alarm 51: UCA lower alarm 52: UA/UB/UC lower alarm 53: channel_1 IA lower alarm 54: channel_1 IB lower alarm 55: channel_1 IC lower alarm 56: channel_2 IA lower alarm 57: channel_2 IB lower alarm 58: channel_2 IC lower alarm 59: channel_3 IA lower alarm 60: channel_3 IB lower alarm 61: channel_3 IC lower alarm 62: channel_4 IA lower alarm 63: channel_4 IB lower alarm 64: channel_4 IC lower alarm
--	--	--	--	---

				65: channel_5 IA lower alarm 66: channel_5 IB lower alarm 67: channel_5 IC lower alarm 68: channel_6 IA lower alarm 69: channel_6 IB lower alarm 70: channel_6 IC lower alarm 71: current lower alarm for any channel 72: PA lower alarm 73: PB lower alarm 74: PC lower alarm 75: total active power lower alarm 76: QA lower alarm 77: QB lower alarm 78: QC lower alarm 79: total reactive power lower alarm 80: SA lower alarm 81: SB lower alarm 82: SC lower alarm 83: total apparent power lower alarm 84: total power factor lower alarm 85: frequency lower alarm 86: DI1 open alarm 87: DI2 open alarm 88: DI3 open alarm 89: DI4 open alarm 90: DI5 open alarm 91: DI6 open alarm
0x4c7	DO1 Alarm Value	Int	1	Secondary side electrical value
0x4c8	DO1 HYS	Int	1	Hysteresis value
0x4c9	DO2 Mode	Int	1	Same as DO1 port
0x4ca	DO2 Act Delay	Int	1	
0x4cb	DO2 Alarm Data	Int	1	
0x4cc	DO2 Alarm Value	Int	1	
0x4cd	DO2 HYS	Int	1	
0x4ce~ -0x4d7	reversed	Int	1	/
0x4d8	Input Net Mode	Int	1	0: 3P4W 1: 3P3W 2CT 2: 3P3W 3CT
0x4d9	Voltage measure range	Int	1	0: 100V 1: 380V
0x4da	Current measure range	Int	1	0: 1A 1: 5A
0x4db	Voltage transformation ratio	Int	1	1-9999
0x4dc	Channel_1 CT ratio	Int	1	1-9999
0x4dd	Channel_2 CT ratio	Int	1	1-9999
0x4de	Channel_3 CT ratio	Int	1	1-9999
0x4df	Channel_4 CT ratio	Int	1	1-9999
0x4e0	Channel_5 CT ratio	Int	1	1-9999
0x4e1	Channel_6 CT ratio	Int	1	1-9999

0x4e2~ 0x4ed	Channel_7~18 CT ratio	Int	1	1-9999 (only for single phase type)
0xbb8	Clear energy counter	Int	1	Send code: 0x0A0A,

Notes:

1. Not all of the data above can be read by RS485, the reading address will be unsuccessful.
2. The data can be read out depends on your multi-function meter model, please refer to the corresponding product manual before build your software.
3. Some software has different definitions of register address, there will be offset, please add 1 for the right address. To get more info, please contact technical support tech@cqbluejay.com

9.4.- Example

Host to Slave inquiry

Addr	FUn	Data Address (high)	Data Address (low)	Data Number (high)	Data number (low)	CRC16 (low)	CRC16 (high)
0CH	03H	00H	00H	00H	06H	C4H	D5H

PC user ask upload UA, UB, UC, IA, IB, IC

Slave to Host answer

Addr	Fun	Byte count	Data1 high	Data1 low	Data2 high	Data2 low	Data3 high	Data3 low
0CH	03H	0CH	03H	E8H	03H	E9H	03H	E8H
Data4 high	Data4 low	Data5 high	Data5 low	Data6 high	Data6 low	CRC16 low	CRC16 high	
13H	84H	13H	88H	13H	8AH	A6H	D6H	

Show the data:

UA=3E8H (100.0)
 UB=3E9H (100.1)
 UC=3E7H (99.9)
 IA=1384H (4.996)
 IB=1388H (5.000)
 IC=138AH (5.002)

Notes:

1. User can write register data for meter testing and remote control the meter
2. When the write is unsuccessful, no return data from the slave, in this addition, user can send write inquiry again

10.- SAFETY CONSIDERATIONS



All installation specification described at the previous chapters named:
INSTALLATION AND STARTUP, INSTALLATION MODES and SPECIFICATIONS.

Note that with the instrument powered on, the terminals could be dangerous to touching and cover opening actions or elements removal may allow accessing dangerous parts. This instrument is factory-shipped at proper operation condition.

11.- MAINTENANCE

The MCM263T does not require any special maintenance. No adjustment, maintenance or repairing action should be done when the instrument is open and powered on, should those actions are essential, high-qualified operators must perform them.

Before any adjustment, replacement, maintenance or repairing operation is carried out, the instrument must be disconnected from any power supply source.

When any protection failure is suspected to exist, the instrument must be immediately put out of service. The instrument's design allows a quick replacement in case of any failure.

For any inquiry about the instrument performance or any failure,
contact to Blue Jay's technical service.

Blue Jay - After-sales service

E-mail: tech@cqbluejay.com