



BLUE JAY[®]
Technology of Electrical Automatic

PRODUCTS CATALOG

CHONG QING BLUE JAY
TECHNOLOGY CO.,LTD



Web:
<https://www.cqbluejay.com/>

Tel:
+86-023-67628702

Mail:
sales@cqbluejay.com

Add:
1802, BUILDING 2, NO. 88, JIANXIN EAST ROAD,
CHONGQING, 400020, CHINA

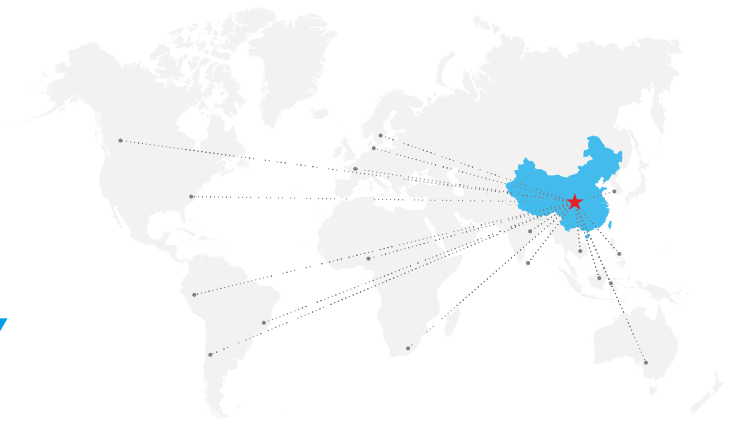

Contents

MEASUREMENT DEVICE

DIGITAL PANEL METER	4
BPM Series Standard Digital Panel Meter	5
APM Series Multi-Function Digital Panel Meter	7
DIN-RAIL ENERGY METER	9
DEM Series Din-Rail Energy Meter	10
MCM Series Multi-Channels Power Meter	14
DC ENERGY METER	16
DCEM Series DC Energy Meter	16
POWER TRANSDUCER	24
QPPX 3-Phases Programmable Power Transducer	25
TR Series Power Transducer	26
CURRENT TRANSFORMER	18
SCT Series Current Transformer	19
DP Series Split Core Current Transformer	20
MES Series Solid Core Current Transformer	21
HCT Series Current Transformer	22
DC SHUNT	23
FL Series DC Shunt	23

AUTOMATIC PROTECTION RELAY

CABINET ENVIRONMENT MONITORING	29
DH Series Peltier Cooler Dehumidifier	29
WSK Series Cabinet Thermostat	31
PROTECTION AND CONTROL	36
PR Series Digital Motor Protection Relay	33
RCM Series AC Residual Current Monitor	40
SWITCHGERA PROTECTION RELAY	42
AFR Series Arc Protection Relay	42
SCM-PD3000 Partial Discharge Monitor	47
SCM-W3000 Wireless Temperature Monitor	49
IMD Series DC Insulation Monitor	51

DIGITAL PANEL METER

Introduction

Blue Jay digital panel meter is a digital alternative to analog display instrument, which has lower cost for installation and can make full use of panel space. It is suitable for indication and monitoring of single-phase or three-phase circuits, accepts various inputs (such as voltage, current, frequency, etc.), provides alarm relay, analog signal transmission and optional pulse output.

We supply high-quality, high-precision BPM series standard digital panel meters and APM series multi-function digital panel meters, which can be used to measure various electrical parameters, including voltage, current, frequency, etc. The large LCD screen helps you easily read the digital results displayed on it.



Reference Standards

Measurement standard

Active energy	IEC 62053-22:2003
Reactive energy	IEC 62053-23:2003
Basic electricity	IEC 61557-12:2007

LVD test standard

IEC/EN 61010-1	2017, CATIII-300V
----------------	-------------------

EMC test

Discharge immunity	IEC 61557-12:2007
Fast transient burst immunity	IEC 62053-22:2003
Surge (Shock) immunity	IEC 62053-23:2003

Application

- Remote data reading.
- Power quality analysis.
- Harmonic measurement.
- Commercial, industrial, utility.
- Medium and low voltage systems.
- Alarm station with voltage-free digital inputs.
- Metering of distribution feeders, transformers, generators, capacitor banks and motors.

Measurement Parameter

Voltage Current Power Reactive power Apparent power	Va, Vb, Vc / Vab, Vbc, Vca Ia, Ib, Ic Pa, Pb, Pc, Psum Qa, Qb, Qc, Qsum Sa, Sb, Sc, Ssum
Frequency Power factor Active energy Reactive energy Voltage THD *	Fra, Frb, Frc, Fr PFa, PFb, PFC, PF Ep_imp, Ep_exp, Ep_total Q_imp, Q_exp, Q_total THD_U%, THD_I%
Harmonic Multi- tariffs Max demand Power quality	2~15 th / 2~31 th / 2~63 th 3 Month, 4 Tariffs, 12 Segment Um, Im, Pm, Qm Voltage Drop / Flicker / Unbalance

BPM SERIES STANDARD DIGITAL PANEL METER

DIGITAL PANEL METER



Introduction

BPM series standard digital panel meter especially developed for indication and supervision of the three-phase circuit, replaces an analogical display meter, reducing installation procedure and optimizing utilization of panel space.

It's ideal for protection of single phase or three-phase networks, it is monitored and usually have superior and subordinate alarms. Protection of the parameters of programming by password.

Main Features

- Measurement functions include: current, voltage, three-phase total power, power factor, frequency.
- 0.5 class (BPM basic series) / 0.5s class (BPM3 economic series) high-precision measurement.
- Large HD LED screen display.
- Password protected programming parameters.
- Protection for single-phase and three-phase networks.
- ITF technology: input and output current insulation protection.
- RS-485 communication, optional expandable I/O modules.
- Various installation sizes, excellent panel space utilization.
- Universal series power supply (85-265VAC/DC), 20-60VDC optional.

Ordering Information

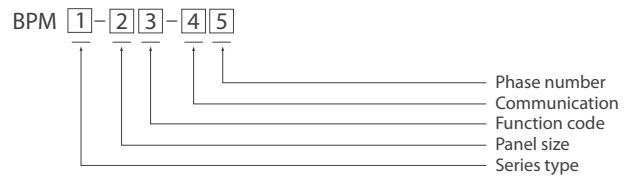

Num.	Code	Description
1	2	Basic type
	3	Economic type
2	96	96(W)x96(H)x71(D)mm
	72	72(W)x72(H)x71(D)mm
	80	80(W)x80(H)x71(D)mm
3	U	Voltage meter
	I	Current meter
	P	Active power meter
	Q	Reactive power meter
	H	Power factor meter
	F	Frequency meter
	UI	Voltage & current combine meter
	UIF	Voltage & current& frequency combine meter
	PQH	Power & power factor combine meter
	E	Economic multifunction meter
4	Blank	Without this function
	R	With RS485 interface, Modbus-RTU
5	1	Single-phase
	3	Three-phases

Note: BPM2 series only can select from num.2-4.

Measurement Function

Model	BPM2/3-96U	BPM2/3-96I	BPM2/3-96P	BPM2/3-96Q	BPM2/3-96H	BPM2/3-96F	BPM3-96UI	BPM3-96UIF	BPM3-96PQH	BPM3-96E
Parameter										
Voltage	●	-	-	-	-	-	●	●	-	●
Current	-	●	-	-	-	-	●	●	-	●
Active power	-	-	●	-	-	-	-	-	●	●
Reactive power	-	-	-	●	-	-	-	-	●	●
Power factor	-	-	-	-	●	-	-	-	-	●
Frequency	-	-	-	-	-	●	-	●	●	●
Active energy	-	-	-	-	-	-	-	-	-	●
Reactive energy	-	-	-	-	-	-	-	-	-	●
Expansion module										
Analogue output	-	-	-	-	-	○	○	○	○	○
Digital output	-	-	-	-	-	○	○	○	○	○
Energy pulse output	-	-	-	-	-	○	○	○	○	●

●With this function ○Optional function -Without this function

Technical Characteristics

Model	BPM2	BPM3
Current measurement (TRMS)		
CT secondary	1 or 5 A True RMS	
Measurement range	0 ... 11 kA	
Input consumption	<0.1 VA	
Voltage measurement (TRMS)		
Measurement range	18 ... 400 VAC True RMS	
PT secondary	100VAC or 400VAC	
Frequency	50 / 60 Hz	
Input consumption	<0.1 VA	
Frequency measurement		
Measurement range	45 ... 65 Hz	
Accuracy	±0.02Hz	
Measurement accuracy		
Voltage, current	0.50%	0.20%
Active power, reactive power	0.50%	0.50%
Active energy	Class 1.0 (IEC 62053-21)	
Reactive energy	Class 2.0 (IEC 62053-23)	
Power supply		
AC voltage	220VAC	AC/DC 90~240 ± 10 %,Optional DC20-60V
Consumption	< 10 VA	
I/O ports		
Pulse outputs (PO)	NONE	Equipped on meter with energy metering
Quantities of port	/	1 or 2
Pulse constant	/	5000imp/kWh 20000imp/kVarh
Optocoupler isolation capability	/	2kVac r.m.s
Relay outputs (DO)	/	Optional
Load capacity	/	5A@250Vac or 5A@30Vdc
Digital inputs (DI)	/	Optional
Quantities of port	/	96mm size meter max 6*DI 80mm and 72mm size meter max 4* DI
Load capacity	/	Ri<500Ω ON, Ri>100kΩ OFF
Analog output (AO)	/	1* 4~20mA, load <390Ω, or 0~10V, load >100KΩ
Quantities of port	/	96mm size meter max 3*AO 80mm and 72mm size meter max 1* AO
Communication		
Protocol	/	Modbus RTU
MODBUS speed	/	4800 / 9600 / 19200 bauds
Others		
Calibration environment	27°C ± 5°C	
Operation environment	0 to 50°C,RH < 70%	
Storage environment	-10 to 60°C,RH < 70%	
Weight	Appx.300-400g	Appx.300g
Dielectric strength (AUX terminal)	2 kV at 50Hz for 1 min	

APM SERIES MULTI-FUNCTION DIGITAL PANEL METER

DIGITAL PANEL METER



Introduction

APM series advanced multifunction digital panel meter. It is the perfect choice for monitoring and controlling power distribution systems, with 4 direct access keys and high-definition LCD display to showing all parameters of 3P3W or 3P4W low voltage installation.

The panel meter can be used as a data acquisition device for an intelligent power distribution system or a factory automation system, and can remote obtain all monitoring data through digital RS485.

Main Features

- PMD measurement accuracy class 0.2.
- Current measurement.../5 or.../1 A.
- Universal series power supply (85-265VAC/DC).
- 1.6-inch dot matrix LCD display.
- LCD liquid crystal display, with backlight.
- Provides load alarms and time stamps.
- SOE record, virtual alarm function.
- ITF technology: input and output current insulation protection.
- Optional 128MB data logger memory.
- Optional expansion I/O, ethernet connection port.
- With RS-485 Modbus RTU communication.
- 128 samples per cycle, 0.5s screen refresh rate.
- Universal series power supply (85-265VAC/DC), 20-60VDC optional.
- Various advanced electrical parameters can display grid status on site (maximum demand/unbalance degree/crest factor/K factor...).
- 1KHz waveform snapshot, captures voltage, current power flickers/drops with a length of 1 second for event tracking.

Measurement Function

Model	APM-5MY	APM-96Z	APM-96Y	APM-96J	APM-96Q
Parameters					
Basic parameters ⁽¹⁾	●	●	●	●	●
Time of use (TOU)	○	○	●	●	●
Harmonic distortion	○	-	●	●	●
Individual harmonic	2~51th	-	2~15th	2~31th	2~63th
Current imbalance	○	-	-	●	●
Voltage imbalance	○	-	-	●	●
Max demand	○	-	-	●	●
Voltage deviation	○	-	-	●	●
SOE record	○	-	-	●	●
Voltage drop / flicker	-	-	-	-	●
Waveform capture	-	-	-	-	●
128MB memory	-	-	-	-	○
Expansion module					
AO (0/4~20mA;0~5V)	-	○	○	○	○
DI/DO	○	○	○	○	○
Communication port					
RS485	●	●	●	●	●
Ethernet 10/100MB	-	-	○	○	○
Profibus	-	○	○	○	○

●With this function ○Optional function -Without this function

(1) Basic parameters:Voltage,Current,Frequency,Total power factor,Active power, Reactive power,Apparent power,Active energy,Reactive energy,Individual harmonic.

Ordering Information

APM - 1 2 - 3 4

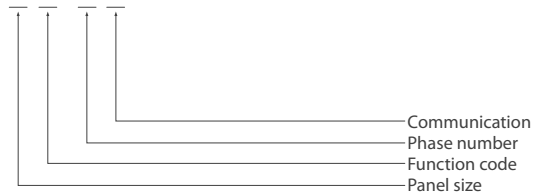

Num.	Code	Description
1	96	96(W)x96(H)x71(D)mm
	72	72(W)x72(H)x71(D)mm
	80	80(W)x80(H)x71(D)mm
	XM	Module width of Din-rail mounting
2	Z	Economic power meter
	Y	Multifunction power meter
	J	Smart power monitor
	Q	Intelligent power analyzer
3	1	Single-phase
	3	Three-phases
4	Blank	Default: With RS485 interface, Modbus-RTU
	Eth	Ethernet interface,Modbus-TCP & Modbus-RTU

Technical Characteristics

Model	APM-5MY	APM-96Z	APM-96Y	APM-96J	APM-96Q
Current measurement (TRMS)					
CT secondary	1 or 5 A				
Measurement range	0...11 KA				
Input consumption	<0.1 VA				
Voltage measurement (TRMS)					
Measurement range	18...400 VAC				
PT secondary	100 VAC/400 VAC				
Frequency	50 / 60 Hz				
Input consumption	<0.1 VA				
Electrical power measurement					
Accuracy (V,I)	0.20%	0.50%	0.20%	0.20%	0.20%
Accuracy (P,Q)	0.50%	0.50%	0.50%	0.50%	0.50%
Frequency measurement					
Measurement range	45...65 Hz				
Accuracy	±0.02 Hz				
Energy accuracy					
Active energy	Class 0.5 (IEC 62053-22)	Class 1.0 (IEC 62053-21)	Class 1.0 (IEC 62053-21)	Class 0.5s (IEC 62053-22)	Class 0.2s (IEC 62053-22)
Reactive energy	Class 2.0 (IEC 62053-23)	Class 2.0 (IEC 62053-23)	Class 2.0 (IEC 62053-23)	Class 1.0 (IEC 62053-24)	Class 1.0 (IEC 62053-24)
Power supply					
AC voltage	DC/AC 85~265 ± 10 %				
Consumption	< 10 VA				
I/O ports					
Pulse output (PO)	1* Pulse, 1600imp/kWh	2* Pulse, 1600imp/kWh			
Pulse constant	5000imp/kWh,20000imp/kVarh				
Relay output (DO)	2* 5A@250Vac / 5A@30Vdc				
Digital Input (DI)	4* Dry contact,Ri<500Ω ON, Ri>100kΩ OFF				
Analog output (AO)	/	1* 4~20mA, load <390Ω,or 0~10V, load >100KΩ			
Communication					
Link method	RS485 (2/3 wires half duplex)				
Protocol	Modbus RTU				
MODBUS speed	4800/9600/19200bauds				
Others					
Calibration environment	27°C ± 5°C				
Operation environment	0 to 50°C, RH < 70%				
Storage environment	-10 to 60°C, RH < 70%				
Dielectric strength (Voltage sampling)	2 kV at 50Hz for 1 min				
Dielectric strength(AUX terminal)	2 kV at 50Hz for 1 min			2 kV at 50Hz for 1 min (Optional:4kV)	

DIN-RAIL ENERGY METER

Introduction

The Din-rail energy meter, an energy meter for DIN rail mounting, used for residential energy metering and smart energy project, and measuring energy usage in industrial environments. High performance DIN rail energy meters can provide cost-effective power and energy metering solutions.

Majority of meters have LCD display and certification approved. Besides, as a leading din rail energy meter manufacturer in China, we support OEM and DOM service for these din rail energy meters.



Reference Standards

Measurement standard

Basic electricity	IEC 61557-12:2007
Active energy	IEC 62053-22:2003
Reactive energy	IEC 62053-23:2003

LVD test standard

IEC/EN 61010-1	2017, CATIII-300V
----------------	-------------------

EMC test

Discharge immunity	IEC 61557-12:2007
Fast transient burst immunity	IEC 62053-22:2003
Surge (Shock) immunity	IEC 62053-23:2003

Measurement Parameter

Basic parameter	Voltage(U), Current (I)@0.2% Power (P, Q, S)@0.5% Power factor (H)@ 0.1% Frequency (Hz)@0.1%
Active energy	Consumed (Ep+)@0.5% Generated (Ep-)@0.5%
Reactive energy	Consumed (Eq+)@2.0% Generated (Eq-)@2.0%

Application

- Replace mechanical meters.
- Tenant sharing, cost sharing.
- Commercial, industrial, utility.
- Middle and low voltage systems.
- Calculation and settlement of household electricity bills.
- Metering of distribution feeders, transformers, generators, capacitor banks and motors.

DEM SERIES DIN-RAIL ENERGY METER

DIN-RAIL ENERGY METER



Introduction

DEM series design for DIN-Rail mounting, suit for residential energy metering and smart energy project. DEM seires has Modbus-RTU and pulse output communication allows seamless integration with data acquisition systems.

Various sub-models available, optional prepaid (IC card), wireless data transmit (4G/5G, Rolar etc.), expansion modules are available in built-in and external versions. Combines high performance smart energy meter, ease of integration to provide a cost-effective power and energy metering solution. Featuring a LCD display designed to simplify setup and local reading of meter data.

Main Features

- 35mm DIN-rail installation.
- High precision measurement.
- Large LCD screen with backlight.
- RS485 port built-in with Modbus-RTU.
- 80A current direct input, 0.04A start current.
- Built-in energy pulse output and alarm output.
- Compatible with both 50Hz and 60Hz systems.
- IEC 62053-21 1.0 Class / IEC 62053-22 0.5 class.
- Optional multiple tariffs and prepaid billing functions.
- 10-400VAC direct voltage input, optional VTs connect.
- Tamper-proof design approved for revenue applications.
- Optional multiple types CTs input: 5A/1A, 333mV, 100mA.
- Universal series power supply (85-265VAC/DC), 20-60VDC optional.

Measurement Function

Model	DEM-2M1D	DEM-3M1C	DEM-4M1D	DEM-4M3C	DEM-7M3D
Parameters					
Basic parameters ⁽¹⁾	●	●	●	●	●
4-quadrant energy	●	●	●	●	●
Max demands	-	-	○	○	○
Multi-tariffs	-	-	○	○	○
RTC	-	-	○	○	○
Others					
RS485 modbus	●	●	●	●	●
Pulse port	1600imp/kwh	1600imp/kwh	1600imp/kwh	1600imp/kwh	1600imp/kwh
Digital output	-	-	-	○	●
Prepaid functions	-	-	○	-	○
Remote control	-	-	○	-	○
Wireless function	-	-	○	-	○

●With this function ○Optional function -Without this function

(1) Basic parameters:Voltage,Current,Frequency,Total power factor,Active power,Reactive power.

Ordering Information

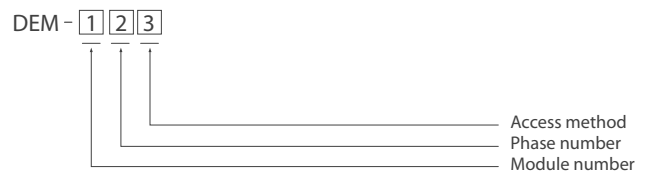

Num.	Code	Description
1	2M	2 Modules width Din-rail
	3M	3 Modules width Din-rail
	4M	4 Modules width Din-rail
	7M	7 Modules width Din-rail
2	1	Single-phase
	3	Three-phases
3	D	Direct access
	C	Use external CT

Technical Characteristics

Model	DEM-2M1D	DEM-3M1C	DEM-4M1D	DEM-4M3C	DEM-7M3D
Basic parameter					
Wiring method	Single-phase,1P2W			Three-phases,3P4W	
Power supply	Self-powered	85-265 VAC/DC	Self-powered	85-265 VAC/DC	Self-powered
Display capacity	9,999,999 KWh	9,999,999 MWh	99,999,999 KWh	99,999,999 MWh	99,999,999 KWh
Voltage rating	230V	100V, 230V	230V	100V, 230V	100V, 220V, 380V
Current	0.04-10(80)A	5A or.../1A CTs	0.04-10(80)A	5A or.../1A CTs	0.04-10(80)A
Measurement accuracy					
Current	0.5%	0.2%	0.5%	0.2%	0.5%
Voltage	0.5%	0.2%	0.5%	0.2%	0.5%
Active energy	Class 1	Class 0.5	Class 1	Class 0.5	Class 1
Reactive energy	Class 2	Class 1	Class 2	Class 1	Class 2
Others					
Module number	2	3	4	4	7
Weight	130g	170g	230g	250g	310g
Temperature	-25°C to 55°C				
IP protection	IP40 front panel and IP20 casing				

DEM-NX MODULAR MULTI-FUNCTION DIN-RAIL ENERGY METER

DIN-RAIL ENERGY METER



Introduction

DEM-NX modular multifunction energy meter is Blue Jay new generation din-rail energy meter. This flexible modular design product can expand max 64 channels metering point, plus 16 points I/O port for on-site control.

Optional 100mA or 333mV CT connect, provide max 0.5 class metering accuracy. RS485 interface or Ethernet interface or extra IoT module valid for different project.

Main Features

- 1.6 inch dot matrix LCD screen.
- Optional IoT expand module.
- Precision metering & sub-billing.
- Optional ethernet expand module.
- RS-485 modbus/RTU communications.
- Core unit provide 15W (12Vdc) drive capacity.
- Universal series power supply (85-265VAC/DC).
- Class 0.2/0.5 basic parameter and class 1 for active energy.
- Flexible combination of up to 40*3P3P/3P4W or 120*1P2W branch circuit metering.

Application

- SCADA. EMS. DCS integrators.
- Medium and low pressure systems.
- All power parameter measurement.
- Energy measurement and electrical fire monitor and control.
- Transformers, capacitors and electric motors distributed detection.

Ordering Information

Model	Description	Specification
DEM-NC	Core unit	85-265Vac/dc, 2* RS485 12V (15W) load capacity
DEM-N32	Three phases metering unit	12Vdc AUX, 1* RS485 2 Channels three phase
DEM-N16	Single phase metering unit	12Vdc AUX, 1* RS485 6 Channels single phase
DEM-NWL	LoRa communication module	12Vdc AUX, 1* RS485 LoRa 2.4G
DEM-NW4G	4G communication module	12Vdc AUX, 1* RS485 4G telecom signal, LTE

Technical Characteristics

Current measurement (TRMS)	
Rating of CT secondary	100mA, 50mA, 2.5mA
Measurement range	0 ... 11 KA
Input consumption	<0.1 VA
Accuracy	0.5% (IEC61557-12)
Impedance	<10 MΩ
Overload capacity	1.2 times of rating, continuous 10 times of rating, 10s
Voltage measurement (TRMS)	
Measurement range	18 ... 300 VAC
PT secondary	100VAC / 400VAC
Input consumption	<0.1 VA
Accuracy	0.5% (IEC61557-12)
Impedance	>1 MΩ
Overload capacity	1.2 times of rating, continuous 2 times of rating, 1s
Frequency measurement	
Measurement range	45 ... 65 Hz
Accuracy	±0.02 Hz
Energy accuracy	
Active energy	Class 1.0 (IEC 62053-22)
Reactive energy	Class 2.0 (IEC 62053-23)
Power supply (DEM-NC)	
Rating	DC/AC 85~265 ± 10 %
Frequency	50 / 60 Hz
Consumption	< 10 VA
Power supply (Expand unit)	
Rated	12 VDC
Consumption	<0.9W
Communication	
Link method	RS485 (2/3 wires half duplex)
Protocol	Modbus RTU
MODBUS speed	4800/9600 bauds
Safty	
Isolation withstand voltage	AC 1KV/1min

MCM SERIES MULTI-CHANNEL ENERGY METER

DIN-RAIL ENERGY METER



Introduction

MCM series multi-channels power meter is special designed metering device for feeder loops. Multi-function design to provide electrical parameter measurement for three-phases or single phase branch circuits, it performs a real-time metering, measures energy consumption and monitors power quality.

Advanced communications options including Modbus via RS485, optional Ethernet port; Multiple digital input ports can collect pulse signal from water meters and gas meters etc.

Main Features

- Measurement accuracy class 0.5.
- Current measuring.../5 or.../1 A.
- Multi-circuits metering.
- With harmonic analysis.
- Optional 6DI, 2DO ports.
- 1.6 inch dot matrix LCD display.
- Advanced electrical parameter measurement.
- Provide 5 virtual alarm triggers.
- With SPDT relay output for alarm output.
- With RS485 modbus RTU communications.
- Optional multi-tariffs ratio.
- Optional max 99 lists SOE record.
- Accept customization designs.

Measurement Function

Model	MCM2603	MCM2601	MCM2403	MCM2401	MCM1000
Parameters					
Basic parameters ⁽¹⁾	●	●	●	●	●
Volt.harmonic distortion	○	○	●	●	-
Curr.harmonic distortion	○	○	●	●	-
Individual harmonic	2-31th	2-31th	2-15th	2-15th	-
Time of use (TOU)	○	○	-	-	-
Voltage imbalance	○	○	○	○	-
Current imbalance	○	○	○	○	-
Max demand	○	○	○	○	-
Voltage deviation	○	○	○	○	-
SOE record	○	○	-	-	-
Measurement signal access					
4 Channels (3P)	-	-	●	-	-
6 Channels (3P)	●	-	-	-	●
12 Channels (1P2W)	-	-	-	●	-
18 Channels (1P2W)	-	●	-	-	○
Communications and i/o port					
Ethernet port	-	-	○	○	-
Profibus	○	○	○	○	○
6 [#] Digital inputs	○	○	-	-	○
2 [#] Digital outputs	○	○	●	●	○

●With this function ○Optional function -Without this function

(1) Basic parameters:Voltage,Current,Frequency,Total power factor,Active power, Reactive power,Apparent power,Active energy,Reactive energy,Individual harmonic.

Ordering Information

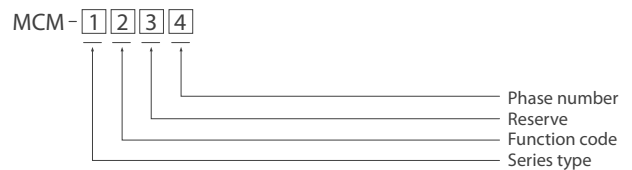

Num.	Code	Description
1	1	First generation
	2	Second generation
2	4	4 Metering ICs built-in
	6	6 Metering ICs built-in
3	0	Reserved item
4	1	Single-phase
	3	Three-phases (Only for second generation)

Technical Characteristics

Model	MCM2600	MCM2400	MCM1000
Current measurement (TRMS)			
CT secondary rated	Standard 1A/5A	100mA,333mV optional	Standard 1A/5A
Measurement range	0 ... 9999A		
Overload	"1.2 times rated continuous; 5 seconds for 10 times the rated"		
Input consumption	<0.2 VA		
Voltage measurement (TRMS)			
PT secondary	100VAC	100VAC / 400VAC	
Frequency	45 ... 65 Hz		
Overload	1 seconds for 2 times the rated		
Input consumption	<0.2 VA		
Direct measurement	18 ... 300 VAC L-N	18 ... 400 VAC L-L(18...250VAC L-N)	
Power supply			
AC voltage	DC/AC 85~265 ± 10 %, 50 / 60 Hz		
Consumption	< 10 VA		
I/O port (alarms / control)			
Number of relays	2 Channel DO & 6 channel DI	1 x SPDT relay	2 Channel DO & 6 Channel DI
Type	230 VAC 5 A, passive node	230 VAC 5 A, passive node	230 VAC 5 A, passive node
Communication			
Link method	RS485 (2/3 wires half duplex)		
Protocol	Modbus RTU		
MODBUS speed	4800/9600/12800/19200bps		

MCM SERIES NEW GENERATION MULTI-CHANNEL ENERGY METER



Introduction

The BLUEJAY New Generation MULTI-CHANNEL ENERGY METER is engineered for precise energy monitoring in both residential and industrial settings. It offers flexible channel configurations from 1 to 24, supporting both single-phase and three-phase measurements for diverse applications.

Designed with rigorous safety standards, the meter meets CATII-300V requirements and can withstand voltages up to 4KV. It also provides versatile communication options, including RS485 and Ethernet, with optional modules such as DI, DO, PO, and AO for enhanced system integration.

Main Features

- 0.5s High accuracy energy measurement;
- Single-phase and three-phase measurements;
- Supports 1 to 24 channels multi-channel configuration;
- Residential and industrial energy monitoring applications;
- CATII-300V voltage safety standards;
- Up to 4KV withstand capability;
- Communication: RS485, Modbus-RTU; Ethernet, TCP/IP optional;
- Expandable modules: DI, DO, PO, AI and AO optional;

Measurement Function

Model	MCM211D	MCM223T	MCM243d	MCM263T	MCM283D	MCM283R
Metering features						
Basic parameters	●	●	●	●	●	●
Volt. harmonic distortion	●	●	●	●	●	●
Curr. harmonic distortion	●	●	●	●	●	●
Individual harmonic	●	●	●	●	●	●
Time of use (TOU)	●	●	●	●	●	●
Curr. / Volt. unbalance	●	●	●	●	●	●
SOE record	●	●	●	●	●	●
Measurement signal access						
1A & 5A	○	●	○	●	○	○
100mA	●	○	●	○	●	●
333mV	●	○	●	○	○	○
L-N 300V,three phases	●	●	●	●	●	●
L-L 480V,single phase	-	●	●	●	●	●
Communications and i/o port						
RS-485/ Modbus RTU	●	●	●	●	●	●
Ethernet 10/100MB	○	○	○	○	○	○
Wi-Fi/4G/Bluetooth	○	○	○	○	○	○
Digital input/ output	○	○	○	○	○	○
Analog input/ output	○	○	○	○	○	○
Pulse output	○	○	○	○	○	○

●With this function ○Optional function -Without this function

(1) Basic parameters:Voltage,Current,Frequency,Total power factor,Active power, Reactive power,Apparent power,Active energy,Reactive energy,Individual harmonic.

Ordering Information

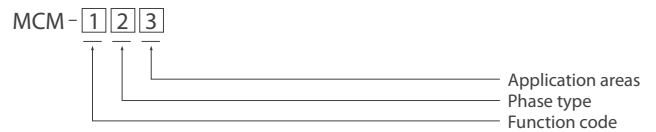

Num.	Code	Description
1	1	1 Metering ICs built-in: for 3*single phase measurement only
	2	2 Metering ICs built-in: for 6*single phase/2*three phases
	4	4 Metering ICs built-in: for 12*single phase /4*three phases
	6	6 Metering ICs built-in: for 18*single phase/6*three phases
	8	8 Metering ICs built-in: for 24*single phase /8*three phases
2	1	Single phase
	3	Three phases
3	T	T: CT access, Default 5A CT, 100mA CT optional, for industrial use t: CT access, 333 mV/100mA CT optional, for residential billing
	D	D: Direct access, for industrial use d: Direct access, for residential billing
	R	R: RJ45 current terminal, for industrial use r: RJ45 current terminal, for residential billing

Technical Characteristics

Model	MCM211D	MCM223T	MCM243d	MCM263T	MCM283D	MCM283R
Current measurement (TRMS)						
Power supply	DC/AC 85~265 ± 10 %, 50 / 60 Hz					
Consumption	< 10 VA					
Measurement channels	3*1P	2*3P/ 6*1P	4*3P/ 12*1P	6*3P/ 18*1P	8*3P/ 24*1P	8*3P/ 24*1P
Current measurement (TRMS)						
PT secondary	100mA,333mV optional	Standard 1A/5A	100mA, 333mV optional	Standard 1A/5A	100mA,333mV optional	100mA,333mV optional
Frequency	0 ... 9999A					
Overload	1.2 times rated continuous; 5 seconds for 10 times the rated					
Input consumption	<0.2 VA					
Voltage measurement (TRMS)						
PT secondary	100VAC / 400VAC					
Overload	1.2 times rated continuous; 5 seconds for 10 times the rated					
Input consumption	<0.2 VA					
Safety						
Voltage level	CATIII-300V		/		CATIII-300V	
Withstand voltage	4KV		2.5KV		4KV	
Communication						
Interface	RS485/Ethernet optional					
Protocol	Modbus RTU/TCP,IP					
Wireless module	Wi-Fi/4G/Bluetooth optional					

DCEM SERIES DC ENERGY METER

DC ENERGY METER



Introduction

DCEM series DC energy meter is mainly used to monitor the DC circuit, which can measure the basic power, demand, extreme value of the DC circuit, and measure the combined electric energy. Moreover, it can measure DC current and DC system electrical parameters. All DC metering device is with RS485 communication interface and the accuracy class is 0.5.

DC metering offered by Blue Jay includes DCEM-7MS, DCEM-5MC, DCEM-96S and DCEM-3MS. It can track the performance of DC systems on multiple parameters. They are used in conjunction with DC shunts or DC transformers, widely used in communication base stations, solar panels, car charging piles, and DC panel.

Main Features

- Small and portable, easy to install.
- Powerful data acquisition and processing functions.
- Ultra-clear screen display, clearly view the measurement results.
- Fast response, rapid measurement of current or voltage changes.
- High precision for accurate current, voltage and resistance measurements.
- High voltage shock resistance reaches level 4; surge anti-interference to level 3.
- Electrostatic discharge immunity reaches level 3; electrical fast transient burst immunity reaches level 4.

Application



Ordering Information

Model	Current signal	Voltage signal	Access	Screen	Dimension
DCEM-7MS	Directly input default 10ADC (Optional 1mA, 20mA, 100mA, 1A/5A)	Typical 100V, Max up to 600V	Directly access / external CT	/	120*110.5*50mm
DCEM-5MC	Hall CT input, default 0-4VDC	Typical 300V, Max up to 1000V	CT	Dot matrix LCD	89*128*41mm
DCEM-96S	Shunt input, default 75mV	Typical 300V, Max up to 600V	Shunt	Segment LCD	96*96*75mm
DCEM-3MS	Shunt input, default 75mV	Typical 300V, Max up to 1000V	Shunt	Segment LCD	50*104*63mm

Technical Characteristics

Model	DCEM-7MS	DCEM-5MC	DCEM-96S	DCEM-3MS
Working power				
Power supply	9~30 VDC	85~265 VDC/AC	85~265 VDC/AC	85~265 VDC/AC
Power consumption	≤4VA	≤4VA	< 5VA	≤4VA
Measurement				
Impedance	> 2 KΩ/V	>1 KΩ/V	>1 KΩ/V	>1 KΩ/V
Overload	Measurement: 1.2 times Instantaneous: 2 times/10s			
Channel	8 Channels	4 Channels	1 Channel	1 Channel
Accuracy (depends on transducer)	U / I :0.2%fs, P :0.2%fs, Energy :0.5%fs	0.5 class	1.0fs for enegyer, 0.5fs for other	0.5%fs
Safety				
Insulation resistor	>100MΩ			
Pressure resistance	Input and Power>2KV; Input and Output>2KV; Power and Output>2KV			
Other				
Communication	RS485 MODBUS-RTU			
Storage environment	-30~75°C			
Working environment	-25~55°C ,Altitude ≤2000m, 98%RH, no condensation, no corrosive gas			

CURRENT TRANSFORMER



Introduction

The current transformer is a current conversion device, which has the dual functions of current conversion and isolation. It converts the large current of the high-voltage circuit or low-voltage circuit into a low-voltage small current (generally 5A), which is supplied to the instrument and relay protection device.

Current transformer are widely used in power systems, industrial automation, and electronic equipment to monitor the magnitude and change of current.



Main Features

- Small size, easy to install.
- Non-contact measurement reduces difficulty of installation and maintenance.
- High measurement accuracy, accurately measure size of the current.
- Effective isolation of the measured current loop and the measurement circuit.
- Rapid response to current changes, real-time monitoring and feedback of current signals.
- Various output methods, such as analog signal output, digital signal output or communication interface output.

Application

- Wind power.
- Automatic industry.
- Solar energy generation.
- Electric vehicle charging pile.
- Power monitoring and control.
- Power meter calibration and inspection.
- Electrical equipment monitoring and protection.
- IoT device monitoring and control.

Working Principle

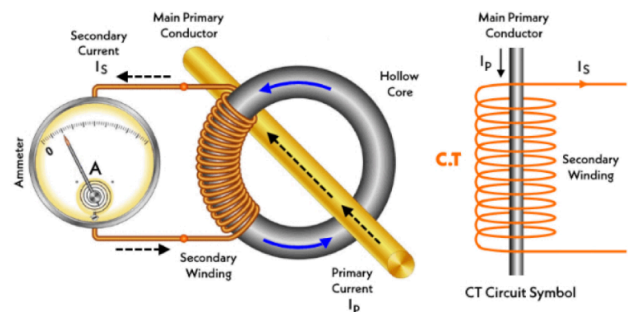

SCT SERIES CURRENT TRANSFORMER

■ CURRENT TRANSFORMER



■ Introduction

SCT series split-core current senses AC current from 30 to 600 Amps passing through the center conductor.

Split core design permits non-contact current measurements through magnetic field induction without requiring that the primary wire be taken offline and disconnected for CT installation. This method permits a safer, easy and portable current measurement.

■ Main Features

- Split core design, low core loss and high precision.
- No need to disconnect the busbar, easy to install, and does not affect normal power consumption.
- Small size and light weight.
- Buckle opening and closing structure, easy to open and close.

■ Application

- Motor, lighting.
- Electrical instrumentation.
- Automatic control system.
- Electronic multi-function energy meter (APM series meter).
- Instrument measurement and protection.

■ Ordering Information

Model	Input(A)	Output(ma)	CT Ratio (unit:A)	Burden(Ω) Class 0.5	Size (H*W*D)	Core
SCT10	0-30A	0-30ma	1000/1	10 Ω	41*30.7*31.8mm	10mm
	0-60A	0-30ma	2000/1			
	0-80A	0-26.6ma	3000/1			
SCT16	0-100A	0-100ma	1000/1		48.5*36.5*38.6mm	16mm
	0-120A	0-60ma	2000/1			
	0-150A	0-50ma	3000/1			
	0-160A	0-80ma	2000/1			
SCT24	0-100A	0-100ma	1000/1		65*52.6*40.9mm	24mm
	0-200A		2000/1			
	0-300A		3000/1			
	0-400A		4000/1			
SCT36	0-200A	0-100ma	2000/1		87*66.7*49.7mm	36mm
	0-300A		3000/1			
	0-400A		4000/1			
	0-500A		5000/1			
	0-600A		6000/1			

DP SERIES CURRENT TRANSFORMER

■ CURRENT TRANSFORMER



Introduction

DP series split core current transformer protects the current transformer through the core. It has been specially designed to facilitate their installation in new or already existing networks. Connection of conventional CTs usually requires the interruption of the primary side circuit to pass cables or bus-bars through the transformer core or to connect such cables to the primary terminals.

DP series CT core can easily be opened and installed and connected without any supply interruption. Thus saving time and the installation costs. This split core current sensor is for the rated frequency of 50Hz voltage below 0.66KV measuring current power and relay protection.

Main Features

- 100A-6000A AC current input range.
- A standard secondary output rating of 5 amps.
- Revenue grade accuracy meets IEC61000-1 class 0.5 / 1.0.
- Push-open mechanism makes the installation quick and simple.
- Two built-in installation methods: place DP series CT on the wall or busbar.
- Wide inner window allows various types cables and busbars to clamp.

Application

- Sub-metering (MCM Series meter).
- Current transducer.
- Power factor meter.
- Instrumentation.
- KWH meter.
- Current sensing relays.
- Energy management systems.

Ordering Information

Model	Primary current (amp)	Burden (VA)		Size (H*W)	Core (H*W)
		Class 0.5	Class 1.0		
DP-23	100, 150, 200, 250	/	1.5	111*90mm	32*20mm
	300	1.5	2.5		
	400	2.5	3.75		
DP-58	250	/	1.5	146*116mm	80*50mm
	300	/	2.5		
	400	1.5	2.5		
	500, 600	2.5	5		
	750	2.5	5		
	800	3.75	5		
	1000	5	10		
DP-88	250, 300	/	1.5	147*146mm	80*80mm
	400	/	2.5		
	500, 600	1.5	2.5		
	750	2.5	5		
	800	3.75	5		
DP-812	1000	7.5	7.5	188*146mm	120*80mm
	500, 600	/	2.5		
	750	2.5	5		
	800	5	2.5		
DP-816	1000	7.5	3.75	247*189mm	160*80mm
	1200, 1250, 1500	10	5		
	1000	5	10		
	1500	7.5	10		
	2000	10	15		
	2500	15	20		
	3000, 4000, 5000, 6000	20	25		

MES SERIES CURRENT TRANSFORMER

■ CURRENT TRANSFORMER



Introduction

MES solid core current transformer is a range of low-cost molded case 5A current transformers. This solid core CT has an integral hinged plate terminal cover that will accommodate cables up to 41mm in diameter and 35mm wide.

MES solid core current transformer is supplied with a DIN-rail mounting clip and mounting feet. 9 models of solid core current transformers are available.

Main Features

- Silicon steel core.
- Secondary side 5A, optional 1A.
- Built-in hinged terminal cover.
- Primary current from 5A to 3000A.
- Three built-in fixing methods: busbar support mounting, din rail mounting, and tetanic bracket panel mounting.
- This AC current transformer smaller than general model in volume.
- The solid core CT matches requirements in space-limited panels.

Application

- Automatic industry.
- Welding equipment.
- Variable speed drives.
- Power quality monitoring.
- Variable frequency electrical appliances.
- Switched mode power supplies (SMPS).
- Battery supplied applications.
- Uninterruptible power supplies.

Ordering Information

Model	Primary current (amp)	Burden (VA)		Size (W*H*D)	Core (H*W)
		Class 0.5	Class 1.0		
MES-62B	5/5,10/5,15/5,20/5,25/5,30/5,	1.5	2.5	87.5 x 62 x 57mm	None (screw connection)
	40/5,50/5,60/5,75/5,100/5,150/5				
MES-62/20	30/5	/	2.5(4T)	87.5 x 62 x 57mm	Ø22mm
	40/5,50/5	/	2.5(3T)		
	60/5	/	2.5(2T)		
	75/5	/	1.5		
	80/5	/	2.5		
	100/5	1.5	2.5		
	150/5	2.5	3.75		
	200/5	3.75	5		
MES-62/30	30/5	/	2.5(4T)	87.5 x 62 x 57mm	31 x 31mm / Ø30mm
	40/5	/	2.5(3T)		
	50/5,60/5	/	2.5(2T)		
	75/5	/	1.5		
	100/5	1.5	2.5		
	150/5	2.5	3.75		
MES-80/30	30/5	/	2.5(4T)	86.5 x 80 x 77mm	31 x 30mm / Ø30mm
	50/5,60/5	/	2.5(2T)		
	75/5	/	1.5		
	100/5	/	2.5		
	150/5	2.5	3.75		
MES-80/40	100/5	/	2.5	86.5 x 80 x 77mm	41 x 31mm / Ø30mm
	150/5	2.5	3.75		
	200/5	3.75	5		

HCT SERIES CURRENT TRANSFORMER

CURRENT TRANSFORMER



Introduction

The Hall effect series current transformer is a highly advanced and sophisticated device that utilizes the hall effect principle to provide precise and accurate measurements of DC currents. It offers a galvanic isolation between the primary and secondary circuits, ensuring safety and preventing any electrical interference.

The open-loop system generates an electronic output signal that can be conveniently connected to PLC or DSP terminal control systems for direct acquisition and use. With its cutting-edge design and dependable performance, this current sensor is an excellent choice for various industrial applications.

Ordering Information

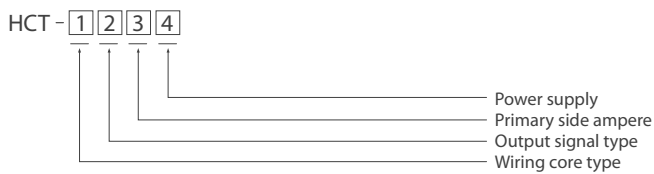

Num.	Code	Description
1	B	Solid core
	S	Split core
2	V	Voltage output
	A	Current output
3	50	50Amp
	100	100Amp
	200	200Amp
	300	300Amp
4	15	±15V
	12	±12V

Main Features

- No insertion losses.
- Small size, easy installation.
- Low power consumption.
- Linear output characteristics.
- Realize remote monitoring and control.
- High immunity to external interference.
- Magnetic field principle, non-contact measurement.
- Short response time, fast response to current changes.
- DC current and AC current measurement.

Application

- Automatic industry.
- Welding equipment.
- Variable speed drives.
- Power quality monitoring.
- Variable frequency electrical appliances.
- Switched mode power supplies (SMPS).
- Battery supplied applications.
- Uninterruptible power supplies.

Technical Characteristics

Parameter	Value
Supply voltage	±12V, ±15V, +12V~+24V
Power consumption	<30mA
Rated output	±4V±1%, 0-5V(+2.5V)±1%, 4-20mADC±1%
Supply voltage	±12V, ±15V, +12V~+24V
Offset drift	@-40~+85°C, ≤±1
Output drift	@-40~+85°C, ≤±1
Response time	≤1s
Isolation resistance	@DC 500v, 1000MΩ
Storage environment	-40 to +85°C

FL SERIES DC SHUNT

DC SHUNT



Introduction

FL series DC shunts are available to measure DC currents. DC shunt can provide a proportional 50~100mV DC output to safely drive a moving coil instrument, overload protection or other control device.

The Manganin shunts have brass ends, available to measure currents from 0.1A up to 10000A, accurate to class 0.5 and are suitable for all DC current monitoring applications. Furthermore, various sizes, configurations, mounting styles of dc shunt are available.

Main Features

- Accuracy: class 0.5.
- Standard tolerance +/-0.5%.
- Have brass ends.
- Various styles are available.

Application

- UPS system.
- Battery management system.
- Telecommunications equipment.
- Electroplating power equipment.
- Motor control and electronic load equipment.
- Solar generators, wind power, heavy industry.

Ordering Information

Model	Picture	Material	Accuracy	Current rating	Voltage drop	Overload
FL-2 Shunt		Brass &Manganin	0.50%	1A~10000A	75mV(standard), 60mV,100mV (customized)	Rated current 120%, 2 hours
FL-2C Patent Shunt		Brass &Manganin	0.50%	1A~10000A	75mV(standard), 60mV,100mV (customized)	
FL-15 USA Shunt		Brass &Manganin& silver welding	0.25%	1A~1000A	25mV,50mV,75mV, 100mV (customized)	
FL-19 Welding Shunt		Brass &Manganin	0.50%	1A~10000A	75mV(standard), 60mV,100mV (customized)	
FL-21 Export Shunt		Brass &Manganin	0.50%	1A~10000A	75mV(standard), 60mV,100mV (customized)	
FL-27/28 High Accuracy Shunt		Brass &Manganin	0.2 & 0.1 & 0.05%	1A~10000A	75mV(standard), 60mV,100mV (customized)	

POWER TRANSDUCER

Introduction

Power transducer is an electrical device used to measure, monitor, and transmit electrical parameters, typically be applied in power systems and industrial control applications.

The main function is to convert power parameters, such as voltage, current, frequency, power factor and active/reactive power, into standard voltage or current signals for monitoring, control and data collection.



Application

- Power system monitoring and management.
- Industrial automation, motor control and protection.
- Data collection and reporting for power equipment.
- Lighting system control and energy saving.
- Battery management systems.

Main Features

- High-precision measures electrical parameters such as voltage, current, and power.
- Signal converts into standard voltage or current signals for easy transmission and processing.
- Features current isolation to safeguard against interference by isolating input and output circuits.
- RS485 remote monitoring and data analysis.
- Programmability: Offers configurability for various parameters and alarm settings.
- Real-time monitoring network performance and stability.

Working Principle

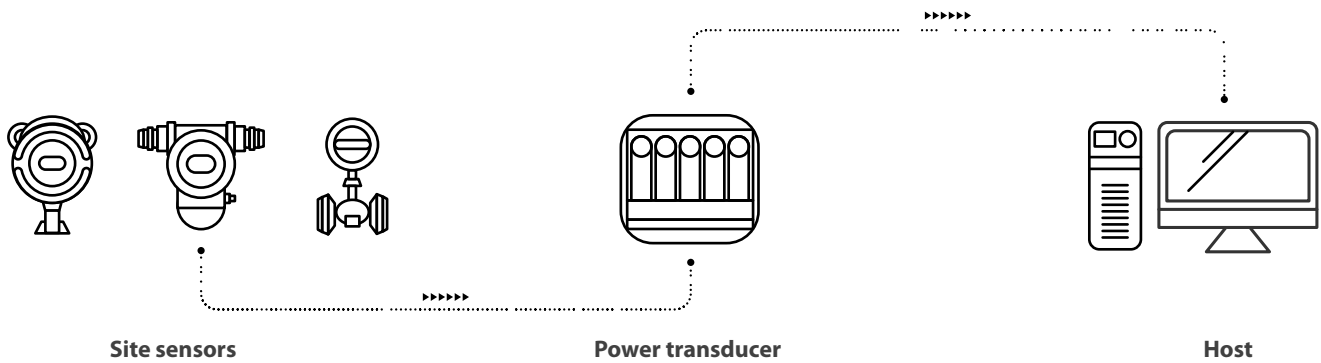

QPPX 3-PHASES PROGRAMMABLE POWER TRANSDUCER

POWER TRANSDUCER



Introduction

QPPX AC programmable transducer has 4 independent channels output, can be used to measure a wide range of electrical parameters and convert analog or digital signals to suitable for meters or PLC control systems. QPPX has signal isolation to ensure transmitted signal safety and accuracy.

Users can easily program, monitor and retrieve measurement data via panel buttons or PC interface. Users can freely configure up to 4 types of data out of 26 different electrical parameters for sampling and generating analog signal output.

Main Features

- 85~265VAC wide range voltage optional.
- 400ms response time, 2000V isolation protection.
- With RS485 port for remote control electrical data.
- Programmable settings, freely configurable parameters.
- Accuracy 0.5 class measurement and signal conversion.
- 35mm Din rail mounting, high-definition screen displays.
- 4 Channel output (max 26 types parameter for analog output).

Application

- SCADA system.
- Industrial automation applications.
- Instrumentation and control systems.
- Renewable energy systems.
- Power generation facilities.
- Utility and grid monitoring.

Technical Characteristics

Parameter	Value
Power supply	AC/DC 85~265VAC/DC
Input	Voltage: 110/220/400VAC (..Customer specified)
	Current: 1/5A AC (Customer specified)
	Frequency: 40-65Hz
Output	DC 4 ~ 20 mA / 0~20mV / 0-5V / 0-10V (..Customer specified)
Load resistance	≤ 510Ω in current output, ≥ 10KΩ in voltage output
Accuracy	≤ ±0.5%
Accuracy drift	Annual variation < 0.2%
Response time	≤ 400 ms
Isolation	Input / output / power supply
Power consumption	AC < 3VA
Case material	ABS fireproof materials
Insulation voltage	AC 2KV RMS / min
Weight	About 450g
Overload voltage	2 times 10 seconds(Instantaneous), 1.2 times in last.
Overload current	10 times 1 seconds(Instantaneous), 1.2 times in last.
Insulation resistance	When AC 500V , ≥100 MΩ
Dimension	87.3(W) X 132(H) X 35(D) mm
Installation	Fixed in a standard 35mm (1.38 inch) DIN rail or screwed on the cabinet.
Working condition	0 ~ 50°C/ less than 95% RH (Non-condensing)
Storage conditions	-20 ~ 70°C/ less than 70% RH (Non-condensing)

TR SERIES POWER TRANSDUCER

POWER TRANSDUCER

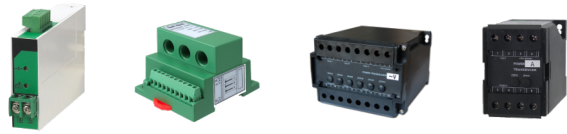

Introduction

TR series power transducer adopts microcontroller technology as the core using the latest algorithms to achieve precise measurement. The AC/DC grid transducer is designed to convert AC/DC voltage or current inputs into a load-independent output signal.

TR series transducer exhibits exceptional temperature stability and reliable operational performance. It derives its output signal through the precise calculation of the root mean square measurement of the input signal, making it compatible with distorted waveforms.

Main Features

- 200ms response time.
- 35mm Din rail mounting.
- 0.2 measurement accuracy.
- RMS measurement and output
- Support customized parameters.
- Single/Three phase independent measurement.
- AC Voltage Input: 110V,220V,380V optional.
- Output: 0-5V,0-10V,4-20mA, 0-20mA optional.

Application

- AC/DC grid systems.
- Medium and low voltage systems.
- Metering of distribution feeders, transformers.
- Generators, capacitor banks and motors.
- Measuring converter: optional association of an instantaneous Analogue outputs available (0...20 mA / 4...20 mA).

Ordering Information

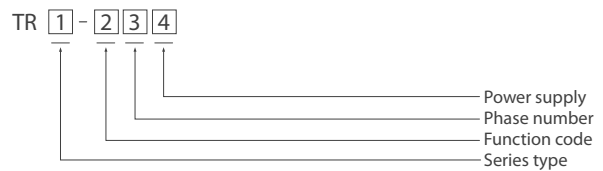

Num.	Code	Description
1	Blank	Default basic type
	D	Digital type,with RS485
	C	CT type,built-in CT
2	U	Voltage
	I	Current
	P	Active power
	Q	Reactive power
	H	Frequency
	F	Power factor
3	1	Single-phase
	3	Three-phases
4	A	For AC grid
	D	For DC grid

Technical Characteristics

Power signal inputs	
Rating	..1A or ..5A C.T. connected 110V, 230V, 400V, 415V ac
Power consumption	<1 VA voltage <0.2 VA current
Overload capacity	1.2 times continuous 5 sec @ 10 times of rated current 2sec @ 2 times of rated voltage
Frequency range	50Hz, 60Hz
Measurement output	
Standard outputs (others on request)	4~20mA, 0~5V
	0~20mA
	5~10V
	0~10V
Maximum load	<750 Ω (0-20mA, 4-20mA) >2000 Ω (voltage output)
Ripple	<1% peak to peak
Response time	<250ms 0-90% <500ms 0-99%
Measurement accuracy	
Class	± 0.5 % complying with IEC 60688
Accurate range	0 - 120% I
Frequency influence	<0.02% per Hz
Load influence	<0.25% of F.S. for specific load range
Auxiliary supply	
Rating	85-265Vac/dc, optional 12V, 24V, 48VDC
Consumption	<3VA
Galvanic isolation between I/O and AUX	
Test voltage	2KV RMS 50Hz for 1 minute
Impulse	4KV 1.2/50 μ sec waveform
Environment	
Operating	-10~55°C
Storage	-40~70°C, 20 ~ 93%RH ; noncondensing

AUTOMATIC PROTECTION RELAY

Introduction

Automatic relay protection is a device used in power systems to automatically detect and respond abnormal conditions such as overcurrent, overvoltage, ground faults, etc. Alarms to protect electrical systems and equipment from potential hazards and ensure safe operation of electrical systems.

Blue Jay's power distribution safety-related products include Arc flash protection relays, Motor protection relays, CBM3000 series switchgear intelligent display operating devices, and WSK, DH series switchgear temperature and humidity control equipment, etc. The product has miniature intelligence, high integration, high sensitivity and high precision, and has higher anti-electromagnetic interference performance and higher IP protection level. It is suitable for various monitoring sites and supporting power cabinet products.



Main Features

- Automatic control, high reliability.
- Ability to record and analyze failure events.
- Modular design, convenient and quick installation and maintenance.
- Quick response: detect and cut off the faulty circuit in time to effectively prevent accidents.
- High-precision measurement and judgment ability, accurately judge the type and location of the fault.
- Versatility: such as overload protection, short circuit protection, ground fault protection, etc.
- 24 hours real-time monitoring, RS485 remote control.

Application

- Industrial automation system.
- Large municipal engineering project.
- UPS system, battery system.
- Real-time monitoring and alarm of power system.
- Substations, power plants, transmission lines, distribution lines.
- Protects motors from overloads, short circuits and motor failures.

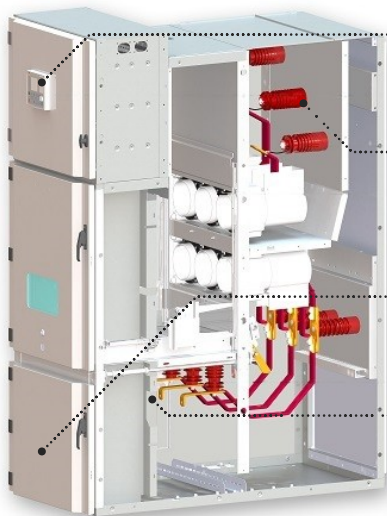

Integrated CB control panel

- CB switch status indicate
- CB switching operation
- Integrate PMD and other functions

Thermal Monitoring (SCM-W3000)

- Surface touch or infrared sensor
- Cable terminations
- CB contact fingers
- Busbar joints

Partial Discharge Monitoring (SCM-PD3000)

- TV and ultrasonic sensor
- PD detection
- PD localization

Arc Flash Protective (AFR)

- High precision fiber probe
- Arc detection
- Arc localization
- Fault protection

DH SERIES PELTIER COOLER DEHUMIDIFIER



Introduction

The DH series peltier condenser adopts semiconductor refrigeration and dehumidification method, sucks humid air through the fan, condenses into water through the semiconductor refrigeration mechanism, and then discharges it from the cabinet through the conduit to achieve a good dehumidification effect. This reduces relative and absolute humidity with little increase in temperature, radically preventing accidents and device aging.

Ultra-small installation size, high efficiency and energy saving, no need for heater and fan wiring. Equipped with a data acquisition module for remote monitoring, a reliable replacement for thermostats and heater/fan combinations.

Working Principle

Moist air sucked in by fan
 ↓
 Condensate cooled by peltier cooler
 ↓
 Condensed water drips into conduit
 ↓
 Drains out of conduit

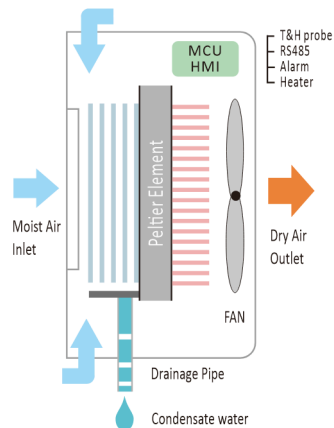

Main Features

- Small size, light weight, easy installation.
- Dehumidification ducts actively induce condensation, discharged gas dehumidified by heating.
- Automatic/manual dehumidification function optional, temperature and dehumidification start value adjustable.
- Humidity and temperature sensor 24-hour real-time sampling, beyond the set start value automatically induced condensation.
- Optional RS485 port, support remote control/adjustment of operating parameters and fault reporting function.
- Do not need extra sensor and probe, optional passive output node for external heater.
- Adopt special moisture-proof components to ensure normal operation in humid environments.

Application

- GIS control cabinets.
- HV/LV control switchgear.
- Ring network cabinets.
- Mechanical control cabinets.
- Box-type substations.
- Dry-type substations.

Ordering Information

Model	Max power	Air volume flow	Sensor	Material	Optional functions
DH1-20	20W	30m³/h	Built-in	ABS	-RS485 Communication -Heater (100-300V) -Alarm (Sensor disconnection alarm, Power loss alarm, Temperature and humidity over limit alarm)
DH2-60	60W	70m³/h	External	ABS	
DH3-60	60W	70m³/h	Built-in	ABS	
DH4-60	60W	70m³/h	External	Sheet metal With anti-rust spray	
DH5-80	80W	100m³/h	External	Aluminum alloy	
DH6-200	200W	140m³/h	External	Sheet metal With anti-rust spray	

Notes:

1. Only Model DH3-60 and DH6-200 can choose all three additional functions, other models can only choose two of three.
2. If the device has a built-in sensor, you cannot select sensor disconnection alarm.
3. Alarm node: default dry node, equipment failure: default normally open.

Technical Characteristics

Model	DH1-20	DH2-60	DH3-60	DH4-60	DH5-80	DH6-200
Working power						
Power supply	85V~265VAC/DC 50Hz					
Peltier rated power ⁽¹⁾	20W	60W	60W	60W	80W	200W
Air volume flow	30m ³ /h	70m ³ /h	70m ³ /h	70m ³ /h	100m ³ /h	140m ³ /h
Dehumidifying capacity	100ml/Day	250ml/Day	250ml/Day	300ml/Day	350ml/Day	600ml/Day
	@35°C,90%RH	@35°C,90%RH	@35°C,90%RH	@35°C,90%RH	@35°C,90%RH	@35°C,90%RH
Measurement and ability						
Humidity monitor range	20%RH~98%RH					
Sensor accuracy	±5%RH					
Dehumidify start threshold	45%RH~98%RH, Default 65%RH					
Environment temperature	5~60°C					
Temperature monitor range	-40~80°C					
Sensor accuracy	±1.0°C					
Heater start threshold	1~55°C, Default 5°C					
Heater power	50~500W optional					
Other						
Physical dimension	75*90*53mm	102*171*73mm	102*140*62mm	132*245*67mm	138*150*70mm	242*247*67mm
Screen	1 digital LED	2 digital LED	2 digital LED	2*3 digital LED	1 digital LED	2*3 digital LED
Standards	IEC60255-22-1					
Communication	RS485, modbus-RTU (Optional)					

Notes:

1. The choice of the rated power is related to the cabinet's inner volume and airtightness, and the general reference value is:

0.5cubic meter cabinet choose 15w,1.0cubic meter cabinet choose 30w,
1.5cubic meter cabinet choose 40w,2.0cubic meter cabinet choose 60w,
Cabinet volume is calculated according to the inner diameter, Length*Width*Height.

2. Sensor accuracy of 5% is tested with the inside probe, product optional external cable type sensor. Please contact the sales team before ordering.

3. Device provides passive NO contact for external heater connection, capacity is AC 250V5A. Users can free to order heaters or purchase with the DH series.

WSK SERIES CABINET THERMOSTAT

CABINET ENVIRONMENT MONITORING



Introduction

WSK series cabinet thermostat is a measurement device used on temperature and humidity control. The humidity control module is integrated in the system, greatly improving the suitability of the equipment, obtaining the temperature and humidity change from the sensor and sending the measured data to the electronic processor. The output device will then control the temperature variation within a specific range.

WSK series cabinet thermostat using load control relay output, has fast output response, accurate PID parameter auto-tuning, support, Modbus communication protocol and is built-in with various output types, allowing different systems to reach a stable control status very quickly, can be used in the worst environment for long-term use, applied to the various occasion which need temperature and humidity control.

Ordering Information

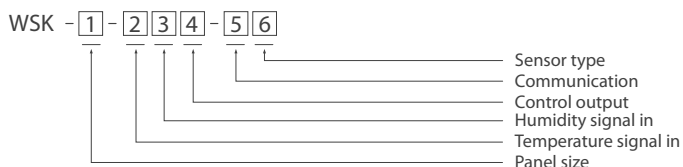

Num.	Code	Description
1	Blank	Standard 48(W) x 48(H)mm
	72	72(W) x 72(H)mm
2	W1	One channel temperature sensor input
	W2	Two channels temperature sensor input
3	S1	One channel humidity sensor input
	S2	Two channels humidity sensor input
4	K1	One channel output
	K2	Two channels output
5	Blank	Without this function
	R	One channel RS-485 communication port
6	Blank	Default select from "Related Accessories"
	T	Thermocouple (-K,-J,-T,-E,-N,-R,-S,-B,-L,-U,-YXK)
	P	Platinum RTD(-PT100,-PT1000)
	L	Linear signal (0~5V,0~10V,0~20mA,4~20mA,0~50mV)

Main Features

- 3 digital or 4 digital LED screens.
- Built-in digital filter reduces interference.
- RS485 MODBUS RTU Communication .
- Standard panel size 48x48mm / 72x72mm.
- Optional 35mm DIN rail (only 48X48mm mode).
- Heat/Fan control mode free to the configuration.
- Sensor length max 10 meters (default 3 meters).
- Accuracy temperature within 1°C & humidity within 5%.
- Support multi sensor input (K, S, T, E, J, B, N, CU50, PT100).

Dimension

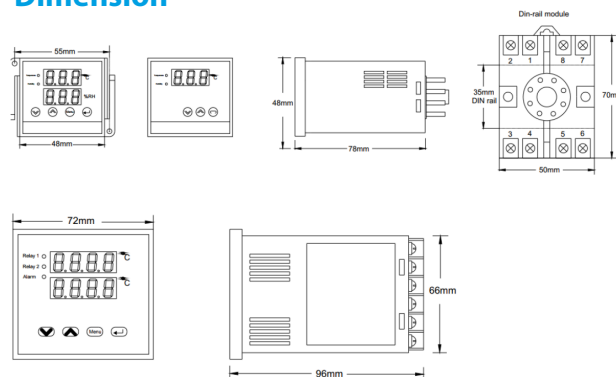

Related Accessories



Model: WSCP-15

- Temperature range: -50~100°C, accuracy ±1%
- Humidity range: 20~95%, accuracy ±5%



Model: WSCP-23

- Temperature range: -20~60°C, accuracy ±1%
- Humidity range: 20~95%, accuracy ±5%



Model: WSCP-35

- Temperature range: -40~125°C, accuracy ±0.3%
- Humidity range : 0~100%, accuracy ±3%

Technical Characteristics

Basic parameters	
Power supply	85V~265VAC/DC 50Hz, optional 24/48DC
Power consumption	≤ 5VA
Dimension (W*H)	48*48mm / 72*72mm
Input	
Temperature	-40~99°C
Temp.sensor accuracy	+/-0.2 °C
Humidity	1~98%RH
Hum.sensor accuracy	+/-3.0%RH
Cable length	2 m.(3m option)
Sampling rate	400 msec/per scan
Output	
Relay output	2-channels, 250VAC, 5A 1PH, resistive load
RS485 communication	MODBUS RTU, 4800/9600bauds
Display	
Waterproof degree	IP40
Display	2-line x 3 character 7-segment LED display
Keypads	Menu, Enter, Increase, Decrease
Environment	
Protection	Anti-containing acid, alkali, salt gas
Temperature	-10~55°C
Relative humidity	<93%, Non-condensing
Storage environment	-10~55°C ; 20 ~ 93%RH ; Noncondensing

PR SERIES DIGITAL MOTOR PROTECTION RELAY

PROTECTION AND CONTROL



Introduction

Digital motor protection relays, integral to motor systems, ensure motor reliability and safety by detecting internal faults (overcurrent, single-phase operation, grounding, bearing issues, and abnormal winding temperatures) and monitoring external conditions to prevent grid fluctuations and voltage surges from impacting the motor.

These relays safeguard motor system stability and power grid reliability by monitoring and controlling internal and external issues and isolating interference sources. It can effectively prevent motor damage and the spread of interference back into the power grid.



Main Features

- Data recording and analysis.
- Variety of protection functions.
- Fault alarm, automatic power off function.
- RS485 remote communication and control.
- Real time motor operating status monitoring.
- Flexible configuration, can customized for specific needs.

Application

- Automated industry.
- High voltage switchgear.
- Solar and wind energy systems.
- Power plant, power grid dispatching.
- Transmission towers and substations.

Measurement Function

	PR201	PR202	PR203	PR240	PR260
Protection function					
Max. start time	●	●	●	●	●
Overload	●	●	●	●	●
Increased safety motors overload	-	-	-	●	●
Over current-jam in starting	●	●	●	●	●
Over current-jam in running	-	●	●	●	●
Phase loss	●	●	●	●	●
Current imbalance	●	●	●	●	●
Over voltage	-	●	●	●	●
Under voltage	-	●	●	●	●
Under power	-	●	●	●	●
Ground fault	-	○	○	●	●
Over current-short	-	-	-	●	●
Over temperature	-	-	-	○	○
Abnormal frequency	-	-	-	●	●
Lead / Lag PF / Low power factor	-	-	-	●	●
Welded contactor	-	-	-	●	●
External fault	-	-	-	-	●
Internal failure	-	-	-	-	●
Restart	-	-	-	●	●
Start mode					
Protection only	●	●	●	●	●
Panel control start/stop	-	-	●	●	●
Forward and reverse start	-	-	●	●	●
Wye-delta transition	-	-	●	●	●
Autotransformer closed transition	-	-	-	●	●
Two-winding	-	-	●	●	●

●With this function ○Optional function -Without this function

PR200 SERIES ECONOMIC MOTOR PROTECTION RELAY

PROTECTION AND CONTROL



Introduction

PR200 motor protection relay comes in a small and economical appearance and designed to real time monitor three-phase power lines for abnormal conditions. can be used with motors below 690V/820A. optional RS485 communication port can upload monitoring data and alarm status to the remote control system.

PR200 provides various protection tripping to avoid motor failure. When PR200 senses that motor operating parameters reach preset alarm value, it will trigger DO port to warn of abnormal conditions; when abnormal parameters continue to accumulate to dangerous values, it will automatically trigger the release switch to close circuit.

Protection Function

IEEE / ANSI C37.2	Protection functions
48	Max. start time
49, 51	Overload
51	Increased safety motors overload
51R	Overcurrent level 1 - Jam
47	Phase loss
46	Current imbalance
50G/N, 51G/N	Ground fault
50	Over current level 2 - Short
32L	Underpower
38	Overtemperature
59	Overvoltage
27	Undervoltage
81U/81O	Abnormal frequency
55	Lead / Lag PF / Low power factor
74	Welded contactor

Main Features

- Built-in 2-channel relay.
- High accuracy sample calculation.
- Programmable analog output function.
- Optional RS485 communication interface.
- Free to configure each protection function.
- Wide range of power supply AC85-265V or AC80-450V.
- Have basic electrical parameter for user SCADA system.
- Build in sequence of event function, max 10 trip records.

Dimension

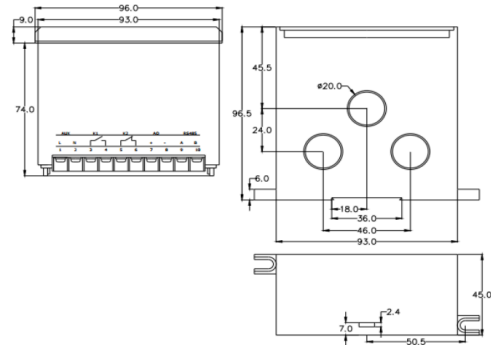

Split installation

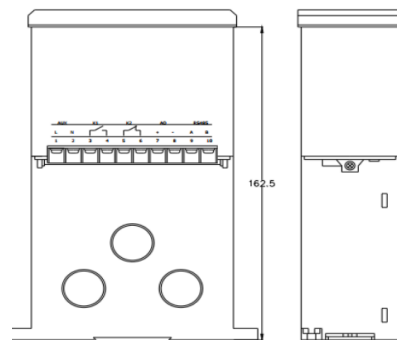

Panel mounting installation

PR240 SPLIT MOTOR PROTECTION RELAY

PROTECTION AND CONTROL



Introduction

PR240 motor protection relay can use with motors less than 690V/820A. It can realize a variety of control operation, such as measurement, self-diagnosis, maintenance management, field bus communication and other functions.

PR240 can real-time monitoring the scene signal, provide various protection trip to avoid motor failure. optional RS485 port can upload monitor data and alarm status to remote control system.

Protection Function

IEEE / ANSI C37.2	Protection functions
48	Max. start time
49, 51	Overload
51	Increased safety motors overload
51R	Overcurrent level 1 - Jam
47	Phase loss
46	Current imbalance
50G/N, 51G/N	Ground fault
50	Overcurrent level 2 - Short
32L	Underpower
38	Overtemperature
59	Overvoltage
27	Undervoltage
81U/81O	Abnormal frequency
55	Lead / Lag PF / Low power factor
74	Welded contactor

Main Features

- Dot matrix LCD display.
- Built-in 4-channels relay.
- Provide various start methods.
- User free to configure each protection function.
- Build in sequence of event function, max 100 trip records.
- With programmable analog output function.
- Optional RS-485 communication interface.

Dimension

Unit: mm

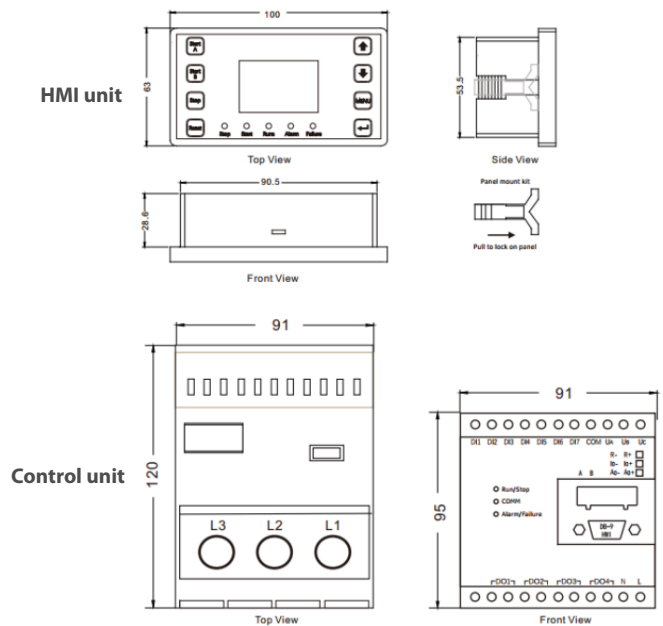

PR260 SERIES MODULAR MOTOR PROTECTION RELAY

PROTECTION AND CONTROL



Introduction

PR260 series motor protection relay is suitable for protecting and monitoring the low-voltage motors with rated voltage less than 690V and rated current up to 820A. It equipped with 7-channels switch monitoring, can be configured as needed. It supports Modbus-RTU communication bus and can transmit monitoring data and alarm status to the remote control system.

PR260 can real time monitor status of motor and detect various faults, such as abnormal start, overload, overcurrent, overheating, blocked rotor, phase loss, unbalance, under voltage, overvoltage, under power, underload, grounding or leakage.

Protection Function

IEEE / ANSI C37.2	Protection functions
48	Max. start time
49, 51	Overload
51	Increased safety motors overload
51R	Overcurrent level 1 - Jam
47	Phase loss
46	Current imbalance
50G/N, 51G/N	Ground fault
50	Overcurrent level 2 - Short
32L	Underpower
38	Overtemperature
59	Overvoltage
27	Undervoltage
81U/81O	Abnormal frequency
55	Lead / Lag PF / Low power factor
74	Welded contactor
86 or 94	External fault
	Data logging
	Wave capture

Main Features

- Record recent 99 trip records.
- Standard RS485 communication.
- Provide 4 digital outputs, and 7 digital inputs.
- Full power measurement, dot matrix LCD display.
- A control unit uses a CT connection with max 5A input.
- Multiple startup modes for different wiring applications.
- Suitable for motors under 0.66KV and any current range.
- Optional waveform capture function for easy fault tracing.
- Extra optional modular: PR-26C extra 2* RS485 or 2* Profibus-DP port.
- PR-265 extra programmable 11*DI and 6*DO.

Dimension

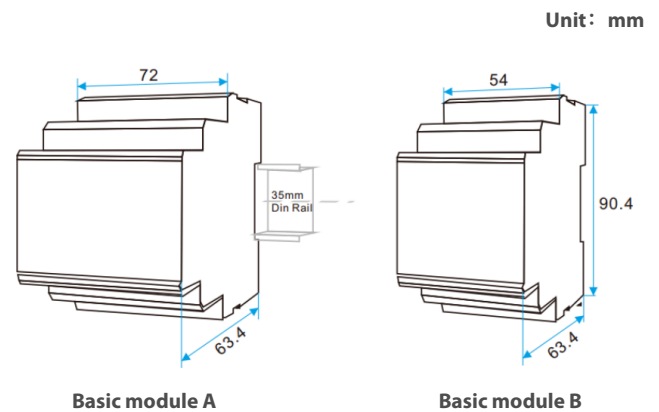

Technical Characteristics

	PR201	PR202	PR203	PR240	PR260
Electrical parameters					
Auxiliary power	85-265 VAC/DC				
Power consumption	<10 VA				
Insulation resistance	> 100 MΩ				
Alarm relay	5 A @ 250V AC, or 5 A @ 30V DC (NO contact)				
Working environment					
Motor rated voltage	AC 380V / AC 660V				
Motor rated current	0.5-820 A				
Working temperature	-10°C ~ +55°C				
Storage temperature	-25°C ~ +70°C				
Relative humidity	< 93% RH				
Altitude	No more than 3000 m				
Atmospheric conditions	Operating place must not have the explosive medium and contain Gases that corrode metals and damage insulating and conductive medium.				
Electrical test					
Electrostatic discharge	IEC 61000-4-2, Level III				
Electrical fast transient burst	IEC 61000-4-4, Level III				
Surge shock	IEC 61000-4-5, Level III				
Withstanding voltage	IEC 61010-1, AC2KV/1min Between power / input / output				
Other					
Digital output	2	2	3	4	4
Digital input	-	-	6	7	7
Analog output	-	1	-	1	1
RS485, Modbus-RTU	-	●	●	●	●
Profibus-DP	-	-	-	-	○
SOE	-	10	10	99	99
Record	-	-	-	●	●
Wave capture	-	-	-	-	●
Display	LED	LED	LCD	LED	LED

CT SELECTION TABLE

FEEDER PROTECTION AND CONTROL



CT selection table

Motor rated power (Kw)	Rated current (A)	Default value
0.06	0.22	10A (CT306)
0.12	0.42	
0.37	1	
0.55	1.5	
0.75	2	
1.1	2.5	
2.2	5	
3	6.5	
5.5	11	
7.5	14.8	
11	21	100A (CT305)
15	28.5	
18.5	35	
22	42	
30	57	
37	69	
45	81	
55	100	
75	135	
90	165	
110	200	

Rated power (Kw)	Rated current (A)	Connected ECT	Expand CT
132	240	CT306 Set Ext. CT 5A	500/5
160	285		
200	352		
220	420		
250	480		

- Notes:
- External protection CT selection guide, typical in 380V motor system
 - If motor rated current more than 200A, need use 5A external CT

External current transformer (ECT)

Motor rated power (Kw)	Rated current (A)	Default value
Measurement 100A-200A	10-100A	0-10A
Secondary to protector 100mA	100A/50mA	10A/5mA
Maximum cable size 30mm	20mm	9mm

Zero-sequence current transformer (ZCT)

Current range	Dimension (mm)								
	φ	A	B	C	D	E	F	G	H
16-100A	45	77	85	24	38	54	9	64	54
100-250A	80	112	122	28	56	80	14	89	80
250-400A	100	131	136	24	66	96	14	108	107
400-800A	150	200	209	28	100	145	16.5	184	177

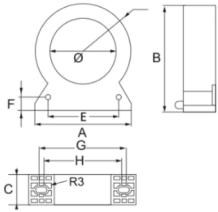

Current range	Dimension (mm)								
	A1	B1	A	B	C	D	E	F	G
0-63A	100	20	133	50	16	144	140	3	2.0
0-100A	100	25	133	60	24	154	143	9	2.5
0-225A	140	32	172	72	24	189	184	9	2.5
0-250A	180	32	212	72	24	229	224	9	2.5
0-400A	220	45	254	86	24	269	264	11	2.5
0-630A	260	45	294	86	24	309	304	11	2.5
0-1600A	300	45	334	86	24	349	344	11	2.5
0-4000A	420	45	454	86	24	469	464	11	2.5

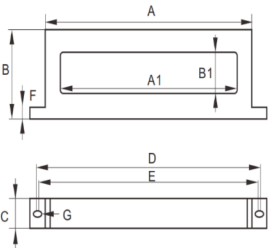

RCM SERIES AC RESIDUAL CURRENT MONITOR

FEEDER PROTECTION AND CONTROL



Introduction

The RCM series (residual current monitor) is designed for measuring residual current and operating temperature in TT and TN-S systems. It can receive signals from multiple sensors to detect and assess faults, residual currents, and operating currents in grounded power supplies.

RCM series can be configured with selected current transformers or temperature sensors to detect parameters and set alarm or trip thresholds. RS485 port allow data transmission to SCADA systems.

Wiring Method

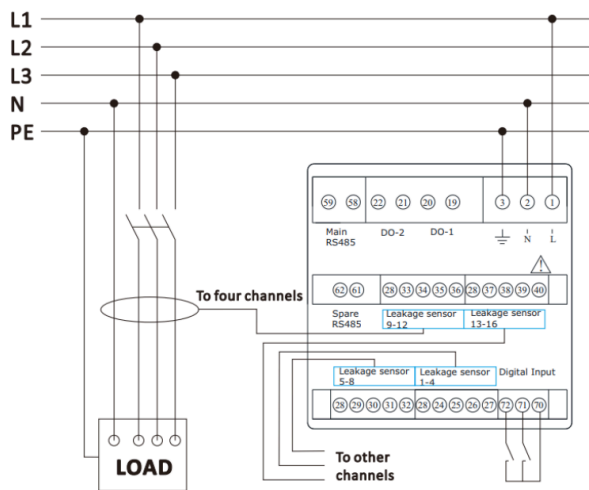

Main Features

- Max 100 history events records with date and time stamp.
- Standard RS485 communication port, Modbus-RTU.
- Support manual self-check, optional 2-way passive open input.
- Backlit graphical display (7-segment display) and indicate LEDs.
- Max 16 measuring channels for residual current or temperature input.
- Residual current alarm setting range 300 ~ 1000mA, minimal adjustment step 1mA.
- The temperature alarm setting range 50.0 ~ 100.0°C, minimal adjustment step is 0.1°C; With 2 relay outputs, free to configuration various protection methods.
- Building in buzzer to provide sound alarm, automatically jump to the alarm interface when protection occurs, key buttons can manual silencing and reset.

Application

- Automated industry.
- Electric vehicle charging pile.
- Stationary electrical equipment and systems.
- Power systems and distribution systems.
- Monitoring critical cable and electrical box temperatures.

Ordering Information

Model	Description
RCM-16IN	16 Residual Current sensor
RCM-8IN8T	8 Residual Current sensor, 8 Temperature sensor
RCM-8IN	8 Residual Current sensor
RCM-4IN4T	4 Residual Current sensor, 4 Temperature sensor

Technical Characteristics

Electrical characteristics	
Power supply	85~265 VAC/DC
Consumption	<5 VA
Residual current accuracy	1%
Temperature accuracy	±2°C
Data refresh rate	1 Sec
Binary inputs	Passive node, isolation voltage 2000VAC
Relay output	AC 250V/5A or DC 30V/5A, 2500V opt coupler isolation
Comm port	RS485 Modbus-RTU protocol, baud rate up to 19200bps
Others	
Physical dimension	96*96*75mm (W*H*D)
Protection class	IP20
Weight	0.55kg
Working environment	-10~55°C
Measurement category	CAT-III, pollution class 2
Insulation capacity	> AC 2kV signal power output
Reference standard	IEC 61000-4-2,class III IEC 61000-4-3,class III IEC 61000-4-4,class IV IEC 61000-4-5,class IV IEC 61000-4-6,class III IEC 61000-4-8,class III IEC 61000-4-11,class III

AFR SERIES ARC PROTECTION RELAY

BUSBAR PROTECTION RELAY



Introduction

AFR series arc protection relay detects electrical arcs in medium and low-voltage equipment, isolating power to minimize the risk of electrical fires. It works to prevent arcing faults in busbars, metal-clad switchgear, and cable boxes.

Arc flash relays can connect with remote light sensors to detect arc flashes and send a trip signal to cut off power. They can be used for stand-alone devices or embedded in complex switchgear layouts.

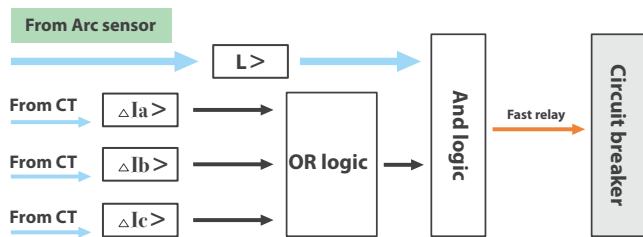

Arc Hazard Diagram

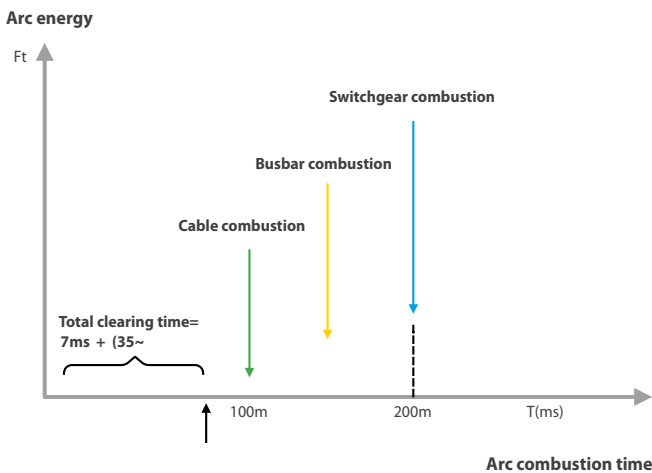

Main Features

- Accurate and real-time monitoring arc signals.
- High temperatures and humidity resistance.
- Fast response, relay tripping in less than 10 ms.
- Equipped with RS485 communication interface.
- Support ST visible light and ST ultraviolet sensor access.
- Complete SOE records, all information power-off retention.
- Support automatic reclosing function to improve system availability.

Application

- Capacitor cabinet.
- High voltage switchgear.
- Electric power substation.
- Large municipal engineering project.
- Medium and low voltage switchgear.
- Thermal power plant electrical section switchgear.
- Wind turbine & Wind farm and photovoltaic station switchgear.

AFR-M ARC FLASH PROTECTION RELAY

BUSBAR PROTECTION RELAY



Introduction

AFR-M busbar ARC flash protection relay represents a cost-effective and highly efficient solution designed to mitigate arc-fault damage. AFR-M detects the emitted light from an arc flash and promptly triggers tripping relay in both low-voltage (LV) and medium-voltage (MV) electrical networks.

Equipped with up to 48 ultraviolet optical sensors, the relay operates on preset programs, ensuring optimal protection for the secure operation of bus circuits.

Terminal Definition

A-Pwr board	B-DO relay board	C-Arc sensor terminal-1	D-Arc sensor terminal-2	E-Arc sensor terminal-3	F-Arc sensor terminal-4	G-DO Comm board	H-Current sensor terminal
A01 Panel/Lamp	B01 DO-1	ARC01	ARC13	ARC25	ARC37	G01 BUS-B+	H01 H01 H02 H01
A02 I/O Channel	B02 DO-2	ARC02	ARC14	ARC26	ARC38	G02 BUS-B-	H01 H03 H04 H01
A03 I/O Channel	B03 DO-3	ARC03	ARC15	ARC27	ARC39	G03 LPSA1	H11 H05 H06 I-C1
A04 I/O Channel	B04 DO-4	ARC04	ARC16	ARC28	ARC40	G04 LPSA2	H21 H07 H08 H21
A05 I/O Channel	B05 DO-5	ARC05	ARC17	ARC29	ARC41	G05 LPSB1	H21 H09 H10 H21
A06 I/O Channel	B06 DO-6	ARC06	ARC18	ARC30	ARC42	G06 LPSB2	H21 H11 H12 I-C2
A07 I/O Channel	B07 DO-7	ARC07	ARC19	ARC31	ARC43	G07 LPSB3	H21 H13 H14 H21
A08 I/O Channel	B08 DO-8	ARC08	ARC20	ARC32	ARC44	G08 LPSB4	H31 H15 H16 H31
A09 I/O Channel	B09 DO-9	ARC09	ARC21	ARC33	ARC45	EXTRA	H31 H17 H18 H31
A10 I/O Channel	B10 DO-10	ARC10	ARC22	ARC34	ARC46	ETH1	H41 H19 H20 H41
A11 I/O Channel	B11 DO-11	ARC11	ARC23	ARC35	ARC47	ETH2	H41 H21 H22 H41
A12 I/O Channel	B12 DO-12	ARC12	ARC24	ARC36	ARC48		H41 H23 H24 I-C4
A13 I/O Channel	B13 DO-13						H25 H26

Main Features

- Arc light and current dual criterion.
- Total 4*3-phase current signal input.
- 16* passive DI point, indicates CB status.
- Single unit max 48pcs opt-sensor connected.
- HD LCD display to show integrated information.
- Independent trip act and alarm act arc flash relay.
- 9* trip contacts, free to configuration protect trip logic.
- Optional extra monitor functions by RS-485 connection.
- Panel mounting design with rugged aluminum housing.
- 1* ethernet port support IEC60870-5-103 communication.
- Less than 10 ms operation time from arc flash to arc relay trip.

Application

- Capacitor cabinet.
- High voltage switchgear.
- Electric power substation.
- Large municipal engineering project.
- Medium and low voltage switchgear.
- Thermal power plant electrical section switchgear.
- Wind turbine & wind farm and photovoltaic station switchgear.

Wiring Method

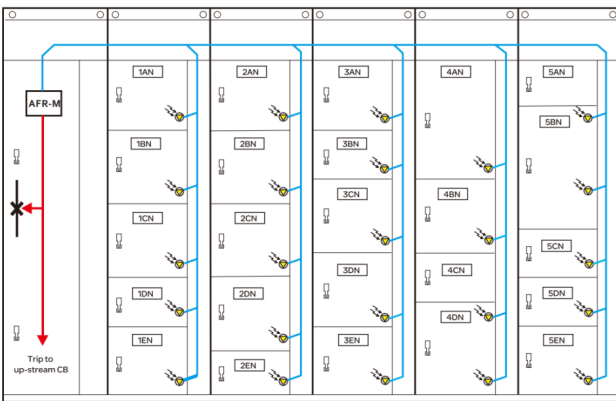

AFR-M Multiple switchgear protection

AFR-S ARC FLASH PROTECTION RELAY

BUSBAR PROTECTION RELAY

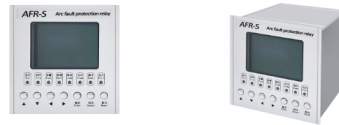

Introduction

AFR-S Arc flash protection relay is a cost-effective solution for minimizing arc-flash damage in low-voltage (LV) or medium-voltage (MV) feeder circuits, commonly recognized as a feeder protection relay. Outfitted with 3 arc sensors, can actively monitors arc faults occurring in cable connections and busbars within the cabinet.

AFR-S features a comprehensive range of functions, including three-stage phase-to-phase overcurrent protection, overload protection, zero-sequence overcurrent protection, arc flash protection, and high-temperature & over-temperature protection.

Terminal Definition

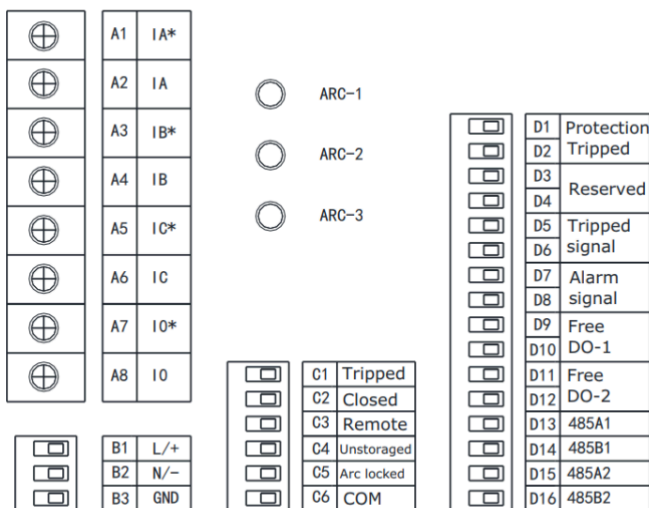

Main Features

- Programmable CB protects trip logic.
- Panel mounting design, HD LCD display.
- multiple passive DI points, indicate CB status.
- Can customized VCB control and protection logic.
- 3-phases current and earth-fault current measurement.
- Less than 10 ms operation time (including output relay).
- Multiple trip contacts, free to configure NC / NO status.
- Optional extra monitor functions by RS-485 connection.

Wiring Method

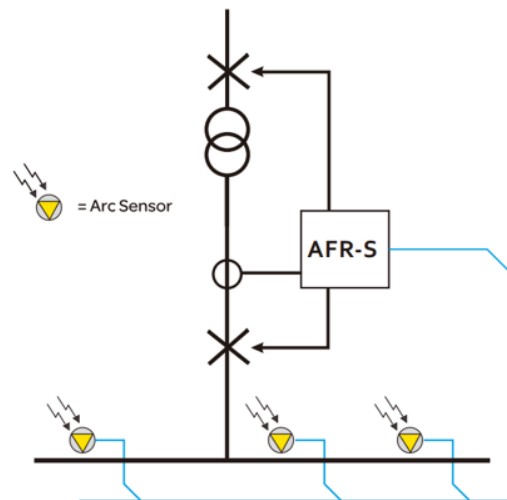

AFR-S Single switchgear protection

AFR-3S ARC FLASH PROTECTION RELAY

BUSBAR PROTECTION RELAY



Introduction

AFR-3S Arc flash protection relays serve as crucial components for detecting arc faults in electrical systems, ensuring the protection of equipment and personnel. AFR-3 adopts advanced monitoring of parameters such as current, voltage, and electric power to swiftly identify arcs.

Designed for application in medium and high-voltage power distribution systems, control cabinets, transformers, generators, motors, and various electrical equipment, the AFR-3 Arc flash relay operates based on a dual-criteria principle. Combining arc light detection with overcurrent detection, it delivers rapid protection responses and high reliability.

Main Features

- Advanced electrical power parameter monitoring.
- Fast response, Identify arc faults in electrical systems.
- Effectively reduce the risk of fire in electrical systems.
- Quickly cut off the power supply to protect electrical safety.
- Adopt the dual criterion of arc detection and overcurrent detection.
- Comprehensive SOE record for analysis and system optimization.

Terminal Definition

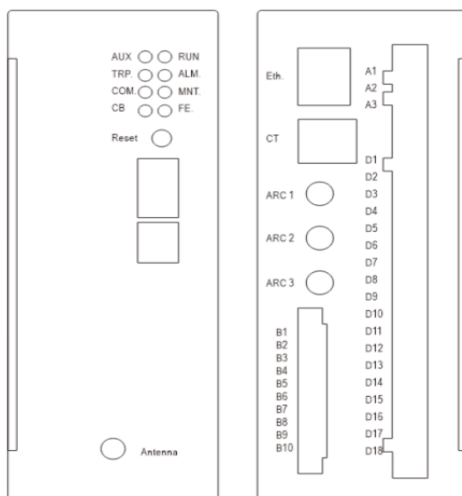

Wiring Method

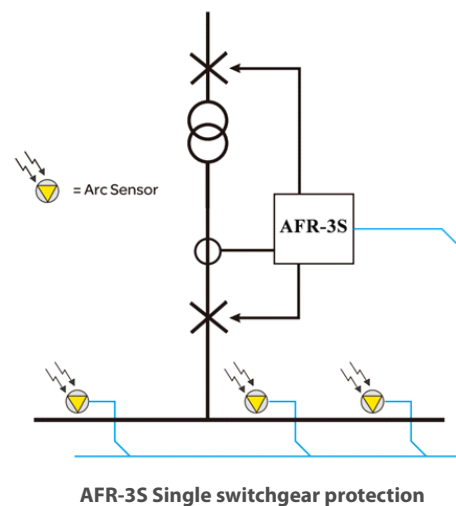

AFR-4 ARC FLASH PROTECTION RELAY

BUSBAR PROTECTION RELAY



Introduction

AFR-4 is a versatile and independently operating device for bay based protection. It supports 4-channels arc signal detection and can configuration multiple arc tripping modes, ensuring accurate and fast fault isolation. With a fast relay output speed up to 5ms, AFR-4 can minimize or completely eliminate arc flash damage, improving system safety and reliability. It can be used in various arc protection applications in low or medium voltage power distribution system.

AFR-4 also provides flash warning and dual criteria tripping mechanism (arc detection + current), providing a comprehensive solution for arc flash protection. Integrated RS485/Modbus communication enables seamless remote monitoring and control, which is ideal for modern power systems.

Main Features

- $\leq 5\text{ms}$ fast relay tripping;
- Regional arc light detection
- Multiple combined tripping modes;
- Circuit breaker failure protection;
- 4 channels of arc light signals detection;
- Dual criteria for arc detection and overcurrent detection;
- Integrated /RS485 MODBUS communication protocol;
- Support ST visible light and ST ultraviolet sensor access.

Terminal Definition

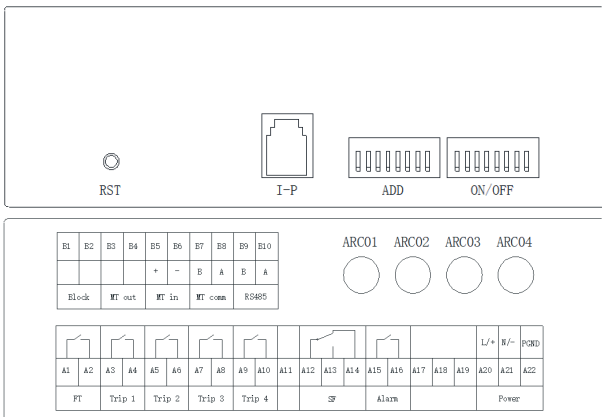

Wiring Method

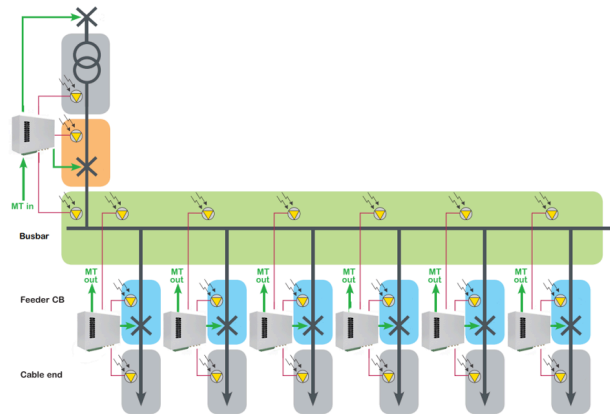

Technical Characteristics

	AFR-S	AFR-M	AFR-3S	AFR-4
Basic parameter				
Power supply	85~265V AC/DC	85~265V AC/DC, optional 24/48V DC	85~265V AC/DC	
Consumption	Monitoring <5W DO triggered <10W	Monitoring <8W DO triggered <10W		
Protection range	0.08~10 In	0~20 In	0.06~10 In	
Rated current (In)				5A or 1A
Burden				<0.5VA
Protect current accuracy	<2%		<4%	
Protect frequency accuracy	0.1Hz			
Arc signal input & control				
Channels number	3	12-48	3	4
Sensor type	Optical fiber			
Detection light type	Visible light/UV light (optional)			
Trip coil contact	AC250V/8A fast relay, passive node			
Trip operation time	Pure arc protection: ≤10ms Overcurrent + arc protection: ≤20ms			Pure arc protection: ≤8ms Overcurrent + arc protection: ≤15ms
DO relay channels	6	9	4/6 (optional)	6
Safety isolation	Photoelectric isolation, isolation voltage 2500V			
RS485 Communication				
Comm port	RS485 Modbus-RTU (one standard, two optional)			
Isolation type	Photoelectric isolation, lightning protection			
Baud rate	9600bps			
Ethernet communication				
Interface	2-Way Ethernet optional		/	
Network parameters	10M/100M adaptive		/	
Default IP	192.168.12.2/192.168.13.2		/	
Others				
Working environment	-10 ~ 55°C, < 93% RH (Non-condensing)			
Storage environment	-30 ~ 70°C, < 70% RH (Non-condensing)			
Relative humidity	5%~95%			
Atmospheric pressure	60kPa~106kPa			

Related Accessories



SCM-OPUV (UV light detection)

- Detection angle: 0-240°
- Photosensitive threshold: 1-10mw/cm²
- Default trigger threshold: 5mw/ cm²



SCM-OPVL1 (Visible light detection)

- Detection angle: 0-240°
- Max.transmission distance: <30 m
- Photosensitive threshold: 5-20KLUX.



SCM-OPVL2 (Visible light detection)

- Detection angle: 0-360°.
- Photosensitive threshold: 5-20KLUX
- Trigger threshold: 8KLUX



SCM-BTM (Busbar temperature monitoring)

- Current: 5 A
- Temperature Range: -40 to 125°C
- Connectivity Type: Wireless



SCM-TEV (Partial discharge sensor)

- Bandwidth: 40 MHz - 80 MHz
- Measurement frequency range: 3M-100MHz
- Measuring range: 0~60dB
- Measurement error: ±2dB



SCM-MK (Smoke sensor)

- Smoke sensitivity: 0.15~0.3dB/m
- Alarm current: ≤45mA
- Communication method: RS485, MODBUS-RTU
- Working temperature: -40°C~+120°C,
≤97%RH(40°C±2°C)

SCM-PD3000 PARTIAL DISCHARGE MONITOR

BUSBAR PROTECTION RELAY



Introduction

Partial discharge is a kind of pulse discharge, which will produce a series of physical phenomena and chemical changes such as light, sound, electrical and mechanical vibration in the interior and surrounding space of power equipment. When insulation defects appear inside high-voltage electrical equipment, it will be accompanied by the generation of partial discharge signals.

SCM-PD3000 partial discharge monitor can be used with UHF sensor, TEV sensor, Ultrasonic sensor and online detection of partial discharge of high voltage equipment such as transformers, high voltage switchgear, GIS, and cable joints. Easy to carry, fast measurement, strong anti-interference ability, easy to use on site.

Working Principle

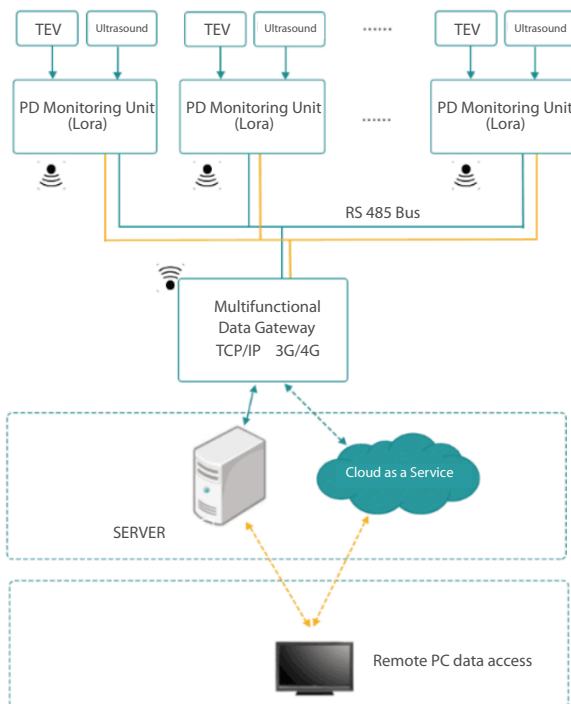

Main Features

- Wall-mounted installation.
- Alarm multi-level threshold setting.
- Waveform data recording function.
- RS 485, Modbus-RTU, SCADA systems.
- Sensor detects TEV and audible ultrasonic.
- Automatic PD data acquisition and analysis.
- 2*DO NC & NO contact for external alarm trig.
- Anti-interference performance and high measurement accuracy.
- Joint detection of partial discharge signals by transient earth waves.
- HMI supports max 96pcs sensor, optional wireless, and wired(RS485) connection.

Wiring Method

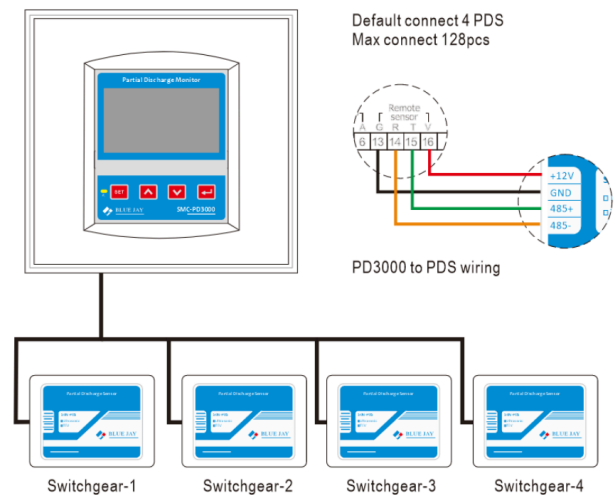

Technical Characteristics

HMI electrical specification	
Auxiliary power	85-265Vac/dc, 20-60Vdc Optional
Power consumption	<6W
Communication	RS-485, MODBUS-RTU
Digital output	2* NC & NO, passive node
Environment temperature	-10 ~ +60°C
Environment humidity	RH 20% ~ 95% (No condensation)
Dimensions (L × W × H)	96*96*85mm or 144*144*100mm
Open install hole	91*91mm or 138*138mm
Remote sensor	
Power supply	12Vdc or 2000mAh build in battery*
Wireless band	433MHz~2.4GHz optional
Signal transmission distance	Up to 80m (260 feet)
Static power consumption	<10mW
Installation method	4* strong magnet, wall mount
TEV sensor	
Detect range	0~60 dBmV
HF frequency response	3~100MHz
Resolution / Accuracy	1dBmV / ±1dBmV
Ultrasonic sensor	
Detect range	-7dBμV~68dBμV
Resolution / Accuracy	1dB / ±1dB
Sensitivity	-65 dB (0 dB=1 volt/μbar rms SPL)
Sensor center frequency	40 KHz

SCM-W3000 SWITCHGEAR THERMAL MONITOR

BUSBAR PROTECTION RELAY



Introduction

SCM-W3000 switchgear thermal monitor designed can enhance safety by enabling operators and maintenance engineers to proactively manage temperature variations in switchgear components, minimizing the risk of sudden temperature increases.

SCM-W3000 provides continuous 24/7 monitoring for critical busbar joints with support for up to 32 monitoring nodes per switchgear. featuring panel mount HMI units with acousto-optic alarms and DO ports, users can integrate it into automatic alarm/control systems. Additionally, the equipped RS485 port allows seamless connection to existing SCADA systems for remote sensing control.



Working Principle

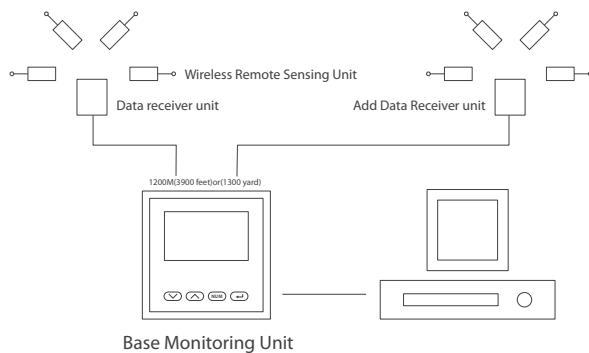

Main Features

- Alarm output (indication through a lighting led).
- Pre-defined high or low temperature conditions.
- Low-size (144 x 144 mm), panel-mounting base unit.
- RS-485 or Ethernet communication to PC (optional).
- Instantaneous, maximum and minimum values of each measured parameter.
- Real-time data 24*7 / 365 Days monitor LV switchgear incomers and feeder, line, and load side.
- Two-level alarm parameter setting. provide 2*DO NC & NO contact for external alarm trig.
- Battery-free design, permanently installed sensors and zero maintenance.

Related Accessories

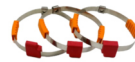

SCM-SAW-S Remote wireless node

- 0-65°C, accuracy 0.5°C
- Maintenance free during life cycle
- Suitable for flat surfaces or VCB contacts



SCM-SAW-W Remote wireless node

- Surface acoustic wave (SAW)
- Maintenance free during life cycle
- External wiring probe for irregular surface



SCM-BAT-S Remote wireless node

- Battery powered, 2000mAh for 2~4 years
- Green/Yellow/Red for three phase
- Suitable for flat surfaces or VCB contacts (test under 2min data transmit interval)

Technical Characteristics

Electrical characteristics	
Power supply	AC / DC 80-270V, 45-65Hz, DC 20-60V (optional)
Maximum power consumption	6W
Wireless remote sensing unit	Standard type 3-12
Temperature monitor range	From 0°C ~ 99 °C
Wireless communication frequency	433Mhz / 460Mhz / 869Mhz
Transmit power	Less than 20mw
Distance of the receiver and monitor	Up to 80m (260 foot)
Others	
Battery life	3-5 years (every fifteen minutes to send a data)
Working environment	Temperature: -20°C~+125°C Humidity: RH 20%~95% (No condensation)
Storage conditions	Temperature: -25°C~+60°C Humidity: RH 20%~95%
Protection	Panel: IP40
Dimensions	Base monitoring unit: 144mm×144mm×110mm Data receiver unit: 65mm×50mm×30mm Wireless remote sensing unit: 65mm×50mm×25mm

DC INSULATION MONITORING DEVICES

DC INSULATION MONITORING



Introduction

DC insulation monitoring devices are specially designed to monitor the insulation status in DC electrical systems. By measuring the insulation resistance in the electrical system, this device can provide high-precision, real-time monitoring and feedback to ensure that the insulation of the electrical system is in a safe state.

The DC insulation monitoring system can quickly detect many DC leakage conditions, including DC ground faults, insulation degradation, AC signal intrusion, and DC signal mutual intrusion. Usually used in DC power supply systems, such as solar power stations, DC transmission system, electric vehicle charging stations.



Main Features

- Automatic alarm system.
- Multiple fault type detection.
- High voltage withstand ability.
- Easy installation and maintenance.
- Real time monitor insulation status.
- RS485 remote monitoring and control.
- Widely used in DC power supply systems.
- High-precision measurement resistance changes.

Application

- Solar power station.
- DC transmission system.
- Railway electrical system.
- New energy storage system.
- Power electronic equipment.
- Electric vehicle charging station.

Working Principle

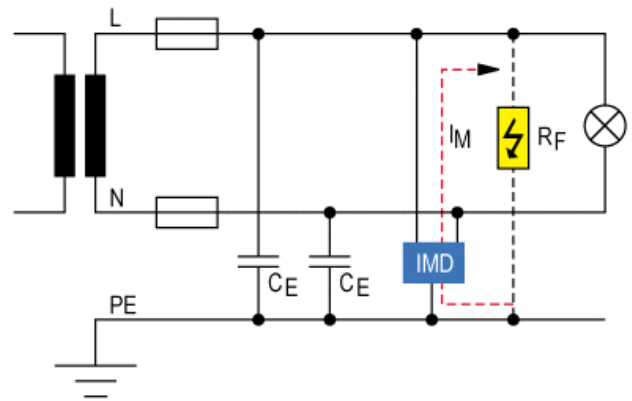

Ordering Information

Series name	Main feature	Special notes
ZJS-102	<ul style="list-style-type: none"> DC voltage range:0-300V Insulation resistance detection: 0-300 KΩ RS485/ Ethernet communication interface W*H*D: 350*180*130mm,Panel mounting 	Balanced bridge principle Specially used for DC panel
ZJJ Series	<ul style="list-style-type: none"> DC voltage range:0-300V Insulation resistance detection: 0-99.9 KΩ W*H*D: 72*100*67mm,Panel mounting 	Adopt pure analog circuit signals
	<ul style="list-style-type: none"> DC voltage range:0-1000V Insulation resistance detection: 0-1999 KΩ W*H*D: 115*105*40mm,35mm Din-rail mounting 	
DCG-UBCS1 Series	<ul style="list-style-type: none"> DC voltage range:100-1000V Insulation resistance detection: 1KΩ~10 MΩ RS485, Modbus RTU W*H*D: 122.5* 75*40mm,35mm Din-rail mounting 	Self-test function optional
DCG-UBC1 Series	<ul style="list-style-type: none"> DC voltage range:100-1000V Insulation resistance detection: 1KΩ~10 MΩ RS485, Modbus RTU W*H*D: 98*49*52mm,35mm Din-rail mounting 	Fault alarm function optional
DCG-UBCH2 Series	<ul style="list-style-type: none"> DC voltage range:100-1000V Dual-channels insulation monitoring Insulation resistance detection: 1KΩ~10 MΩ W*H*D: 145*95*40mm,35mm Din-rail mounting RS485, Modbus-RTU 	RS485 interface, Private protocol
DCG-UBCW2K Series	<ul style="list-style-type: none"> DC voltage range:100-2000V Insulation resistance detection: 1KΩ~10 MΩ W*H*D: 145*115*40mm,35mm Din-rail mounting Fault alarm function RS485, Modbus-RTU 	Widely insulation monitoring range

ZJS-102 DC INSULATION MONITOR

DC INSULATION MONITORING



Introduction

ZJS-102 DC system insulation monitor is a professional online monitoring equipment that uses balanced and unbalanced bridge detection technology to effectively eliminate the interference of distributed capacitance in the system. ZJS-102 can display the leakage current of each circuit in real time and has complete DC insulation fault monitoring functions, including single-point grounding, multi-point grounding, busbar two-pole grounding, etc.

ZJS-102 use transient alarm waveform capture and current synchronous detection technology, the insulation monitoring system records voltage and current fault curves, realizes instantaneous ground monitoring and ground fault location functions, and is an ideal choice for DC power system safety protection.

Main Features

- Circuit insulation classification alarm.
- Instantaneous ground event recording.
- Historical data analysis and download.
- Max support monitoring 240 branches.
- RS485 remote management and control.
- System distributed capacitance detection
- Continuous insulation monitoring and alarm.
- Real-time monitoring and alarming of AC /DC voltage.
- High-precision 16-bit AD converter, PLC integrated digital output.

Working Principle

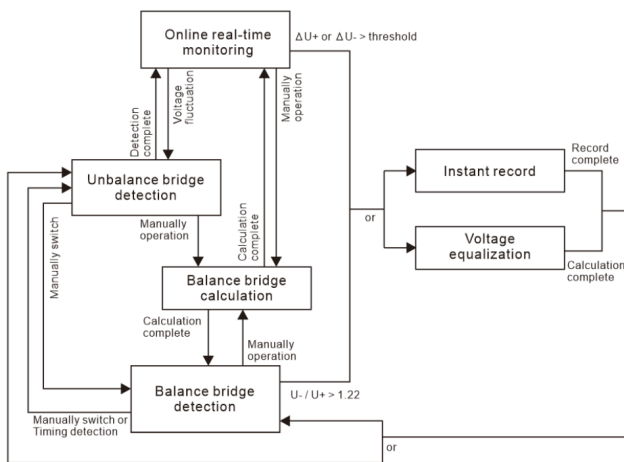

Wiring Method

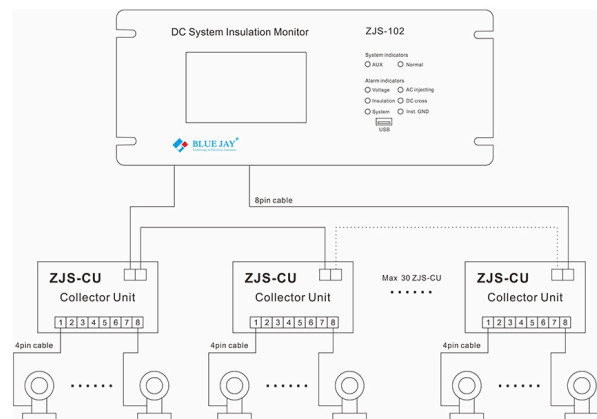

Technical Characteristics

Monitoring range of system insulation resistance to ground	
Earthing alarm	0-99.9K
Pre-warning	100-999.9K
Monitoring and detect range of branch insulation resistance to ground	
0-300K	
Working voltage range	
Positive pole to ground	0-300V
Negative pole to ground	0-300V
System voltage	0-300V
AC injection voltage	0-280V
Busbar-II system voltage (DC cross detect)	0-300V
Battery bank insulation fault location error	±1 cell
Alarm history record	
Record list quantities	2000 lists
Each record alarm list volume	≤32 branches
Real-time leakage current measurement	
Screen display resolution	0.01mA
Current sensor range	10mA, 20mA, 50mA, 100mA optional
Each ZJS-102 port detect current volume	≤ 240 branches
Each ZJS-CU collector unit connected current sensor	≤8
Instant event record	
Capture sampling ratio	1KHz, 500Hz, 250Hz, 125Hz configurable
Record quantities	2000
Waveforms for each instantaneous event	8
Others	
Passive digital output	7
Fault alarm indicator	6
Distributed capacitance range of the system	0-200uF

ZJJ SERIES DC INSULATION MONITOR

DC INSULATION MONITORING



Introduction

ZJJ series DC insulation monitoring relay is an advanced device specially designed for monitoring the insulation condition of DC busbar. Using a fully calculated hardware voltage dividing circuit, it can directly display the ground resistance value, solving the problem of old-fashioned relays that only display the ground current or have no display. A highly sensitive ground resistance monitoring and display circuit can quantitatively evaluate the insulation degree of the DC system, which is crucial to ensuring the safe operation of the system.

The ZJJ series DC ground fault detector monitors the insulation condition of the DC busbar and the grounding resistance of the positive and negative buses online in real time. It adopts a fully static circuit, including a highly sensitive ground resistance monitoring and display circuit. When the insulation monitor is lower than the set value, a warning signal is issued. ZJJ-4SA adopts panel installation, while ZJJ-4SC adopts Din-rail installation.

Main Features

- Bridge balance method for resistance measurement.
- Smaller short-circuit grounding current for safe operation.
- Alarm resistance threshold online display and direct setting.
- Terminals are pluggable for easy maintenance and replacement.
- Monitoring the DC circuit bus bar's RF to earth insulation resistance.
- Direct LCD busbar grounding resistance values, positive and negative.
- Reinforced shell, modular structure, high reliability.
- Wide monitoring voltage, 48-1000V, working voltage 24-220V can be customized, adjustable response value ranges of 0-100kΩ.

Working Principle

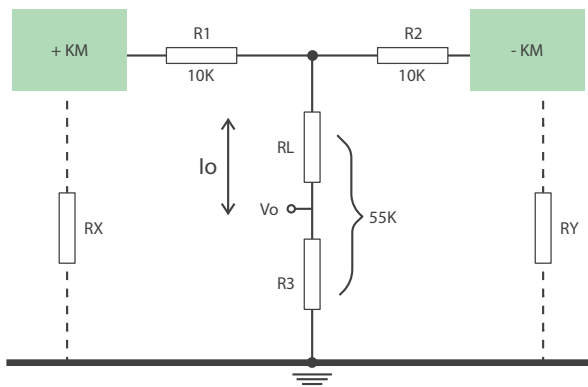

Dimension

ZJJ-4SA: Panel Mounting

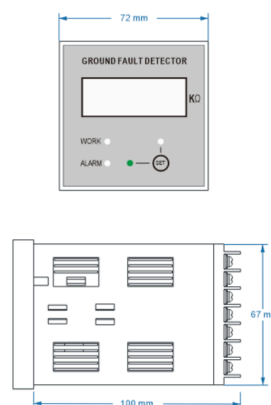

ZJJ-4SC: Din-rail Mounting

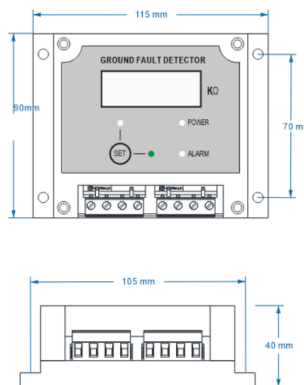

Technical Characteristics

Basic parameters	ZJJ-4SA	ZJJ-4SC
Input voltage	0-300VDC	0-1000VDC
Power supply voltage	Self-powered	85-265 VAC/DC
Power supply current	7-20mA	
Measuring resistance	0~99.9KΩ	0~1999.9KΩ
Relay capacity	10A@250VAC / 30VDC	2A@250VAC
Measurement accuracy	V=220V (5%)	V=1000V (5%)
Alarm setting range	0~100KΩ	0~990KΩ
Short circuit ground current	V=220V (2mA)	
Action return factor	Rs=50KΩ(95%-98%)	
Output contact capacity	Sensitive load=5mS(DC220V0.2A) Resistive load(DC220V 2A)	
Installation type	Panel mount	Din-rail mount
Operating temperature	-40°C ~ 70°C, RH 85%	

DCG-UBCS1 SERIES INSULATION MONITORING RELAY

DC INSULATION MONITORING



Introduction

DCG-UBCS1 (-ST) is a DC insulation monitoring device based on MODBUS protocol, including DC to ground insulation impedance monitoring, DC voltage monitoring, DC voltage reverse connection alarm and other safety monitoring functions. It can be used for electric vehicle DC charging system, photovoltaic system, energy storage system, DC grid and other DC systems below 1000V.

DCG-UBCS1 (-ST) has the function of starting and stopping insulation monitoring. After insulation monitoring is started, the insulation resistance of positive and negative poles to ground can be monitored in real time. The monitoring result is not affected by DC voltage fluctuation, and is not affected by the symmetry of insulation resistance of positive and negative poles.

DCG-UBCS1	Standard model
DCG-UBCS1-ST	With Self-test function

Main Features

- Rail mounting or screw fixing.
- Voltage reverse polarity alarm.
- High voltage grounding switch.
- Convenient parameter setting.
- Adaptive capacitance to ground.
- Monitor positive and negative poles.
- Insulation monitoring equipment self-test.
- RS485 remote monitoring and management.
- Widely insulation monitoring range (100V~1000VDC).

Terminal Definition

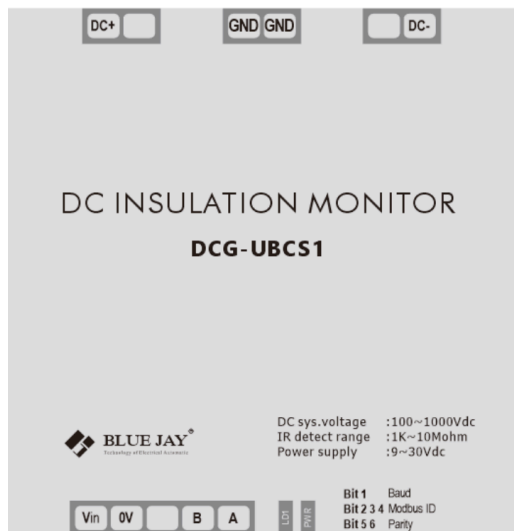

Self-test Working Principle (DCG-UBCS1-ST)

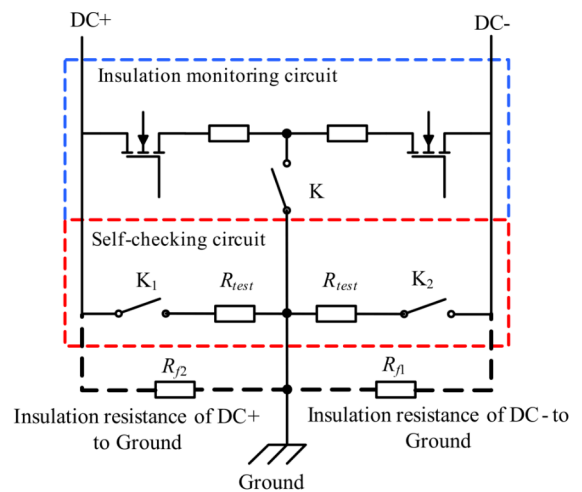

Technical Characteristics

Basic parameters			
Power supply	10-30VDC, power 3W		
DC voltage range	100V~1000V		
DC voltage measurement accuracy	≤2V+0.3%		
Insulation resistance measurement range	1KΩ~10MΩ (DC System voltage:100V~1000V)		
Insulation monitoring accuracy (When :DC voltage:100V-1000V)	CY range	Resistance range	Accuracy
	0~0.8μF	≤60KΩ	≤3KΩ
		60kΩ<R≤1MΩ	≤5%
	0.8μF ~3μF	≤60KΩ	≤6KΩ
60kΩ<R≤1MΩ		≤20%	
Off-line pressure test	<2mA		
Maximum relay switching voltage	250VAC/30VDC		
Maximum relay switching current	3A		
Relay contact resistance	<100mΩ		
Relay insulation resistance	100MΩ		
Communication	RS485,modbus RTU		
Dimension	98*49*52mm,Din-rail:35mm		
Standard	IEC 61851-23 (2014-03):2014-11		
Humidity	85%		
Storage environment	- 40°C ~125°C		
Operating environment	- 40°C ~75°C		

Other parameters		
Pressure point	Maximum voltage rating	Time
DC+/DC- to GND	4200VDC/3000VAC	≤1min
Power supply +/- to GND	3500VDC/2500VAC	≤1min
RS485 A/B to GND	3500VDC/2500VAC	≤1min
DC+/DC- to power supply +/-	3500VDC/2000VAC	≤1min
DC+/DC- to A/B	3500VDC/2000VAC	≤1min

DCG-UBC1 SERIES INSULATION MONITORING RELAY

Introduction

GYDCG-UBC1 is an efficient insulation monitoring device specially designed for car charging piles. It can monitor the insulation status of the DC power supply system of charging piles in real time, detect potential insulation faults in time and alarm, effectively preventing fires and safety accidents. Users can realize start-stop and data collection of insulation monitoring through RS485 communication.

GYDCG-UBC1K-ARH is a DC-to-ground insulation monitoring module based on the unbalanced bridge principle, integrating monitoring and protection functions. It can monitor the insulation resistance value of the positive and negative poles of the DC floating system to the ground, ranging from 1KΩ to 10MΩ, and detect the DC voltage value, ranging from 100V to 1000V. In addition, GYDCG-UBC1K-ARH is equipped with a high-voltage grounding switch to realize online on-off function to ensure complete isolation from the ground when the module is powered off, reset or stops working.

DCG-UBC1	Standard model
DCG-UBC1K-ARH	With Fault alarm function

Terminal Definition

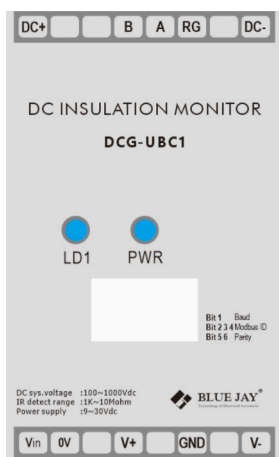

DCG-UBC1

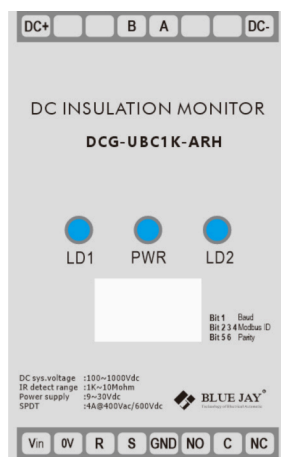

DCG-UBC1K-ARH

DC INSULATION MONITORING



Main Features

- Adaptive capacitance to ground.
- Simple device setting by DIP switch.
- Faster monitoring speed of turning on.
- Communicate with RS485 modbus.
- Equipped with high voltage grounding switch.
- Wider DC insulation monitoring range DC 100~1000V.
- Unbalanced bridge principle for resistance measurement.
- Monitoring the DC circuit bus bar insulation resistance RF to earth.

DIP Switch Settings

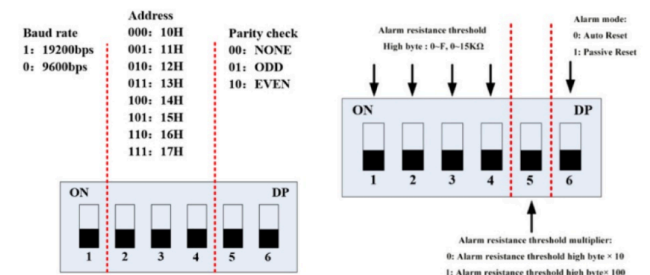

DCG-UBC1

DCG-UBC1K-ARH

Technical Characteristics

Basic parameters			
Power supply	10-30VDC, power 3W		
DC voltage range	100V~1000V		
DC voltage measurement accuracy	≤2V+0.3%		
Insulation resistance measurement range	1KΩ~10MΩ (DC System voltage:100V~1000V)		
Insulation monitoring accuracy (When :DC voltage:100V-1000V)	CY range	Resistance range	Accuracy
	0~0.8μF	≤60KΩ	≤3KΩ
		60kΩ<R≤1MΩ	≤5%
	0.8μF ~3μF	≤60KΩ	≤6KΩ
60kΩ<R≤1MΩ		≤20%	
Off-line pressure test	<2mA		
Maximum relay switching voltage	250VAC/30VDC		
Maximum relay switching current	3A		
Relay contact resistance	<100mΩ		
Relay insulation resistance	100MΩ		
Communication	RS485,modbus RTU		
Dimension	98*49*52mm,Din-rail:35mm		
Standard	IEC 61851-23 (2014-03):2014-11		
Humidity	85%		
Storage environment	- 40°C ~125°C		
Operating environment	- 40°C ~75°C		

Other parameters		
Pressure point	Maximum voltage rating	Time
DC+/DC- to GND	4200VDC/3000VAC	≤1min
Power supply +/- to GND	3500VDC/2500VAC	≤1min
RS485 A/B to GND	3500VDC/2500VAC	≤1min
DC+/DC- to power supply +/-	3500VDC/2000VAC	≤1min
DC+/DC- to A/B	3500VDC/2000VAC	≤1min

DCG-UBCH2 SERIES INSULATION MONITORING RELAY

DC INSULATION MONITORING



Introduction

DCG-UBCH2 series is used in on-line monitoring insulation resistance of the DC floating system (Dual DC system shared one ground). Dual DC channels are controlled independently, two DC insulation monitoring non-interference in each other. Users can enable or disable the insulation monitoring function of each DC channel and acquire insulation resistance values by RS485 communication.

DCG-UBCH2 series adopts Dual-DC channels independent control scheme. Users can control dual-channel startup, close and data reading respectively according to the communication protocol.

DCG-UBCH2	RS485, Private protocol
DCG-UBCH2-LZ	RS485, Modbus RTU

Main Features

- Dual-channels independent control.
- Remote monitoring and management.
- Monitor positive and negative poles.
- Ground insulation resistance.
- DC voltage monitoring.
- Vehicle side DC voltage monitoring.
- Voltage reverse polarity alarm.

Working Principle

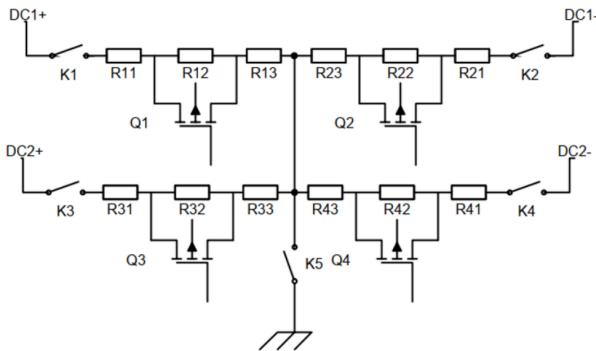

Terminal Definition

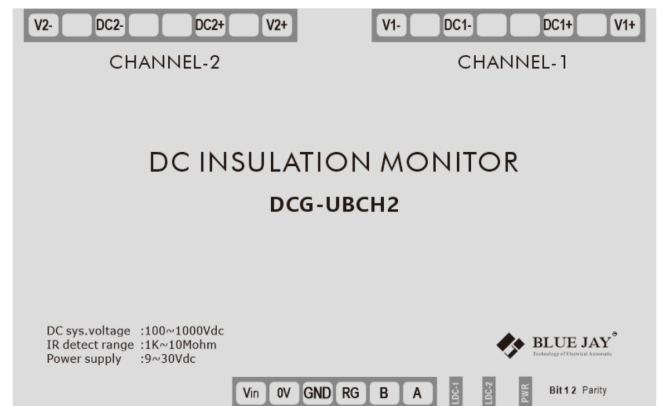

Technical Characteristics

Basic parameters			
Power supply	10-30VDC, Power 6W		
DC voltage range	100V~1000V		
DC voltage measurement accuracy	≤2V+0.3%		
Insulation resistance measurement range	1KΩ~10MΩ (DC System voltage:100V~1000V)		
Insulation monitoring accuracy (When :DC voltage:100V-1000V)	CY range	Resistance range	Accuracy
	0~0.8μF	≤60KΩ	≤3KΩ
		60KΩ<R≤1MΩ	≤5%
	0.8μF ~3μF	≤60KΩ	≤6KΩ
60KΩ<R≤1MΩ		≤20%	
Off-line pressure test	<2mA		
Communication	RS485,Modbus RTU/ Private protocol		
Dimension	145*95*40mm,Din-rail:35mm		
Standard	IEC 61851-23 (2014-03):2014-11		
Humidity	85%		
Storage environment	- 40°C ~125°C		
Operating environment	- 40°C ~75°C		

Other parameters		
Pressure point	Maximum voltage rating	Time
DC+/DC- to GND	4200VDC/3000VAC	≤1min
Power supply +/- to GND	4200VDC/3000VAC	≤1min
RS485 A/B to GND	4200VDC/3000VAC	≤1min
DC+/DC- to power supply +/-	4200VDC/3000VAC	≤1min
DC+/DC- to A/B	4200VDC/3000VAC	≤1min

DCG-UBCW2K-RSA INSULATION MONITORING RELAY

DC INSULATION MONITORING



Introduction

GYDCG-UBCW2K series is a DC to ground insulation monitoring module based on the principle of unbalanced bridge, which has monitoring and protection functions in one. It can monitor the insulation resistance value of the positive and negative poles of the DC floating system to the ground, ranging from 1KΩ to 10MΩ; at the same time, it can also detect the DC voltage value, ranging from 100V to 2000V.

After the insulation monitoring function is turned on, the product can continue to monitor the insulation resistance in real time, and user can read the insulation resistance value as soon as 1 second after the insulation monitoring function is turned on. For the DC-to-ground capacitance, module can realize self-adaptive monitoring the ground capacitance below 3μF (the positive and negative poles to the ground capacitance are respectively below 3μF, and the total capacitance is below 6μF).

Main Features

- High voltage grounding switch.
- Widely power supply range.
- Widely insulation monitoring range (100V~2000VDC).
- Insulation monitoring equipment self-test.
- Adaptive capacitance to ground.
- Convenient parameter setting.
- Remote monitoring and management.
- Monitor positive and negative poles.
- Ground insulation resistance.
- Voltage reverse polarity alarm.

Working Principle

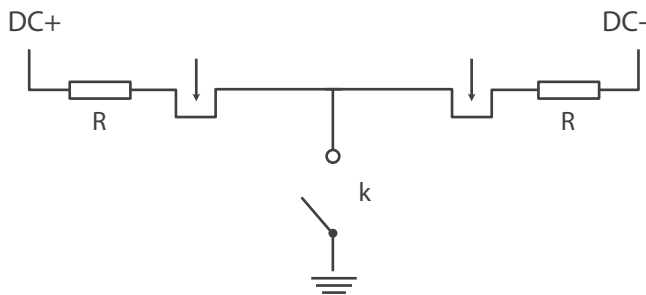

Terminal Definition

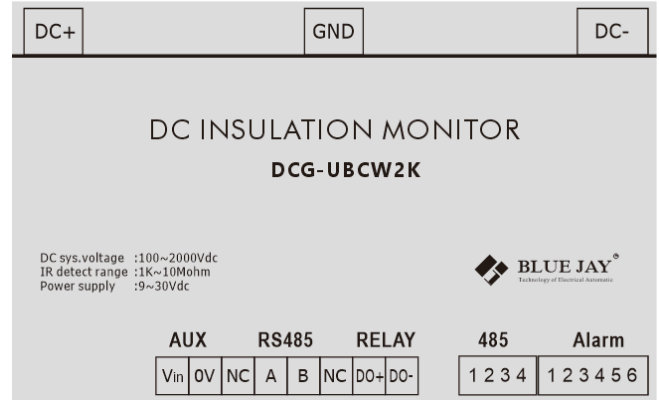

Technical Characteristics

Basic parameters		
Power supply	10-30VDC, Power 3W	
DC voltage range	100V~2000V	
DC voltage measurement accuracy	≤2V+0.3%	
Insulation resistance measurement range	1KΩ~10MΩ (DC System voltage:100V~1000V)	
Insulation monitoring accuracy	DC voltage:100V-300V	≤3KΩ+10%
	DC voltage:300V-2000V	≤3KΩ+5%
	CY>0.3μF, insulation resistance>1MΩ or CY>1μF	>10%
Off-line pressure test	<2mA	
Maximum relay switching voltage	250VAC/30VDC	
Maximum relay switching current	3A	
Relay contact resistance	<100mΩ	
Relay insulation resistance	100MΩ	
Communication	RS485,Modbus RTU	
Standard	IEC 61851-23 (2014-03):2014-11	
Dimension	145*115*40,Din-rail:35mm	
Humidity	85%	
Storage environment	- 40°C ~125°C	
Operating environment	- 40°C ~75°C	

Other parameters		
Pressure point	Maximum voltage rating	Time
DC+/DC- to GND	4200VDC/3000VAC	≤1min
Power supply +/- to GND	3500VDC/2500VAC	≤1min
RS485 A/B to GND	3500VDC/2500VAC	≤1min
DC+/DC- to power supply +/-	3500VDC/2500VAC	≤1min
DC+/DC- to A/B	3500VDC/2500VAC	≤1min

**CHONG QING
BLUE JAY TECHNOLOGY
CO.,LTD**

www.cqbluejay.com



Tel:
+86-023-67628702

Mail:
sales@cqbluejay.com

Add:
1802, BUILDING 2, NO. 88, JIANXIN EAST ROAD,
CHONGQING, 400020, CHINA

