

BIM-M1000

Insulation Monitoring Device

User Manual



Version: 1.11

Revision: 2026.04

Read me

When you use BIM-M1000, be sure to read this user manual carefully, and be able to fully understand the implications, the correct guidance of operations in accordance with user manual, which will help you make better use of BIM-M1000, and help to solve the various problems at the scene.

1. Before turning on the power supply, be sure that the power supply within the provisions of the instrument;
2. When installation, the current input terminal must non-open, voltage input terminals must Non-short circuit;
3. Communication terminal (RS485) is strictly prohibited to impose on high pressure;
4. Be sure the instrument wiring consistent with the internal system settings;
5. When communicating with the PC, instrument communication parameters must be consistent with the PC.



- **Please read this user manual carefully**
- **Please save this document**

Directory

1.- SUMMARIZE	- 1 -
2.- TECHNICAL PARAMETERS	- 2 -
3.- FUNCTION INTRODUCTION	- 4 -
3.1.- Insulation resistance monitoring function	- 4 -
3.2.- Auto and manual reset function	- 5 -
3.3.- Alarm function	- 5 -
3.4.- DI/ DO function	- 6 -
3.5.- Line disconnection detection function	- 6 -
4.- INSTALLATION AND START-UP	- 7 -
4.1.- Installation method	- 7 -
4.2.- Dimension (Unit: mm)	- 8 -
4.3.- Indicator lights and button function description	- 9 -
4.4.- Terminal Definition	- 10 -
4.5.- Typical wiring diagram	- 11 -
5.- COMMUNICATION INTERFACE	- 13 -
5.1.- CANbus communication connection	- 13 -
5.2.- RS485 communication connection	- 13 -
5.3.- RS485 communication protocol	- 14 -
5.4.- Register map	- 15 -
6.- SAFETY CONSIDERATIONS	- 22 -
7.- MAINTENANCE	- 22 -

1.- SUMMARIZE

The BIM-M1000 is designed to monitor the insulation resistance of ungrounded AC/DC IT systems up to 1000 Vac/dc. The device continuously monitors the insulation status by injecting a ± 15 V pulsed measurement signal into the system. The product offers two independently settable alarm thresholds; when the insulation resistance falls below the set value, the corresponding alarm indicator light will illuminate to indicate a fault and relay also trip output.

The BIM-M1000 complies with IEC 61557-1:2018 and IEC 61557-8:2018 standards and is application for AC/DC IT systems, battery energy storage systems, electric vehicles, and DC charging facilities. Support RS485/ Modbus RTU communication and optional CANbus interfaces, the device can be easily integrated into host computers or remote monitoring systems.

Feature

- Insulation monitoring of unearthed AC/DC system;
- Measure single-pole insulation fault in DC system (DC+ to earth and DC- to earth);
- Measurement system-to-ground insulation fault in AC system (L1 and L2 to earth);
- Two separately configurable response values;
- Alarm signaling via LEDs and alarm relays;
- Complies with IEC 61557-1 and IEC 61557-8;
- Automatically adapt to system Y capacitance $<20\mu\text{F}$;
- Programmable 2DI/ 2DO;
- Voltage over-limit alarm function;
- Up to 8 configurable alarm functions;
- DC offset monitoring function;
- Supports manual/automatic reset of fault and alarm information;
- Supports RS485/ Modbus RTU communication;
- Optional CANbus communication interfaces;

Application

- AC and DC IT power distribution systems;
- Industrial power and automation;
- Battery packs and energy storage systems;
- Electric vehicles and transportation;
- Renewable energy generation systems;
- DC charging stations for electric vehicles;

2.- TECHNICAL PARAMETERS

Supply voltage

Power supply	20-60Vdc, power consumption \leq 5W
Frequency range	40~65Hz

Monitored IT system

Nominal system voltage	0...1000 Vac/dc
Frequency range	40~65Hz

Insulation resistance

Insulation resistance measurement range	0~30M Ω
Insulation resistance measurement accuracy	0~100 K Ω , $C_Y \leq 2\mu\text{F}$, Bus voltage stability: ± 12 K Ω 100 k Ω ~1 M Ω , $C_Y \leq 2\mu\text{F}$, Bus voltage stability: ± 10 % 1 M Ω ~30 M Ω , $C_Y = 0\mu\text{F}$, Bus voltage stability: ± 10 %

High voltage input internal resistance

When powered on (internal high-voltage relay closed)	Positive and negative poles to earth: 5.1 M Ω respectively
When powered off or not operating (internal high-voltage relay opened)	Positive and negative poles to earth: > 500 M Ω

Measuring circuit

Injection measuring voltage	$\pm 15\text{V}$
Injection measuring current	$< 100\mu\text{A}$
Injection pulse signal frequency	Self-adaptive, depending on the Y-capacitance (C_Y) value and insulation resistance value.
Permissible system leakage capacitance	$\leq 20\mu\text{F}$

Alarm relay output

Quantity	2* SPDT relay
Max. switching current	$> 100\text{mA}$
Max. withstand voltage	12Vdc
Load capacity	5A@250VAC

Alarm-1 (IR pre-alarm)	Default 1000Ω, 0-5000Ω adjustable, But must< alarm value
Alarm-2 (IR alarm)	Default 500Ω, 0-5000Ω adjustable

Relay input

Quantity	2*DI for reset/ test, NO, active dry contact, with internal 15Vdc pull-up voltage
Load capacity	Ri<500Ω turn on, Ri> 100KΩ turn off

Withstanding voltage

Standard version

High voltage to low voltage: 3500Vdc; 2500Vac (rms)
CAN to high voltage: 3500Vdc; 2500Vac (rms)

Standard version

High voltage to low voltage: 7000Vdc; 5000Vac (rms)
CAN to high voltage: 7000Vdc; 5000Vac (rms)

Communication

RS485 interface	Modbus RTU protocol
Canbus interface (optional)	Custom protocol

Environment

Working temperature	- 40°C ~85°C
Storage temperature	- 40°C ~85°C, humidity: 5~95%RH

Others

Standards	IEC 61557-1:2018 and IEC 61557-8:2018
Installation method	Standard 35mm Din-rail mounting
Dimension	W*H*D: 108*110*66mm

3.- FUNCTION INTRODUCTION

3.1.- Insulation resistance monitoring function

The BIM-M1000 continuously monitoring the insulation resistance of IT systems (ungrounded systems). When the measured insulation resistance falls below the preset alarm threshold, the corresponding alarm relay trips out, and the LED indicator illuminates to issue an alarm. For proper measurement, the device must be connected between the IT system and the protective earth conductor (E). the measurement current is applied to the system and detected and evaluated by the measuring circuit.

After power-on, the “PWR” indicator turns on, and the device enters insulation resistance monitoring by default. The operating mode can be configured via registers 0x006E to “manual trigger insulation monitoring after powered on.” In this mode, insulation monitoring does not start automatically after powered on and It is also necessary to manually enable or disable the insulation monitoring function via Register 0x0070. Additionally, users can select the present measurement mode (DC or AC system) in Register 0x006F. For further details, please refer to [chapter 5.4.2](#).

In DC systems, the insulation resistance of the positive and negative terminals to ground can be measured independently.

In AC systems, interference from high-frequency voltage harmonics can be suppressed, allowing for accurate measurement of the insulation resistance to ground of the entire AC system.

If DC to ground capacitance exists, the module can adaptively monitor grounding capacitance below 3 μ F (positive and negative capacitances to ground are both below 3 μ F, total capacitance below 6 μ F), with a monitoring time not exceeding 25s in the presence of ground capacitance.

Working principle:

BIM-M1000 insulation monitoring device adopts the active measuring method principle (signal injection principle) to continuously monitor insulation in unearthed systems. The device is connected between the live conductors and earth, superimposes a ± 15 V measuring voltage to the system.

When the system insulation is intact, the resulting measuring current is minimal. If an insulation fault occurs, the measuring circuit closes, generating a small current inversely proportional to the insulation fault. The device’s internal electronics continuously capture and analyze this measuring current, and an alarm is triggered when the insulation resistance drops below the preset response value.

3.2.- Auto and manual reset function

The BIM-M1000 supports both manual reset and automatic reset modes. The reset mode can be selected via register 0x0071. The **RST** button on the front panel is effective for reset function only when manual reset mode is selected.

Automatic reset mode (default): When fault occurs, the output signal is activated immediately (e.g. self-test fault indicator turns on, alarm indicator lights up, relay output is energized). When the fault is cleared, the output signal automatically returns to the normal status.

Manual reset mode: When fault occurs, the output signal is activated immediately (e.g. self-test fault indicator turns on, relay output is energized). Even after the fault is cleared, the output signal remains in “fault” status until manual reset by pressing the **RST** button.

Note: Alarm function 1-8 only supports automatic reset. Selecting manual reset for these alarms is invalid.

3.3.- Alarm function

BIM-M1000 supports up to 8 types of configurable alarm function for monitoring critical parameters, the alarm thresholds can be flexibly configured to enable accurate system condition warning and protection.

Alarm No.	Item	Parameter	Value
Alarm-1	Insulation resistance pre-alarm	IR pre-alarm	100Ω/V~10000Ω/V
Alarm-2	Insulation resistance alarm	IR alarm	
Alarm-3	Voltage over threshold	Volt	0-1000V
Alarm-4	System leakage capacitance over threshold	YCap	0-20μF
Alarm-5	DC offset over threshold	DCoff	20-1kV
Alarm-6	Reserved function	Rfu	/
Alarm-7	Reserved function	Rfu	/
Alarm-8	Reserved function	Rfu	/

3.4.- DI/ DO function

BIM-M1000 supports 2 channels DO for alarm status output, and 2 channels DI for external control signals input.

Configuration	Parameter	Value
Relay output	Mapping	OFF, Alarm-1, Alarm-2, Alarm-3, Alarm-4, Alarm-5, Alarm-6, Alarm-7, Alarm-8
	Link	OFF, Alarm-1, Alarm-2, Alarm-3, Alarm-4, Alarm-5, Alarm-6, Alarm-7, Alarm-8
	Logic	AND, OR
	Mode	NC: Normally close NO: Normally open Flash: relay is flashing, flashing frequency: 1 second ON / 1 second OFF

Configuration	Parameter	Value
Relay input	Mode	OFF Active high Active low
	Delay	Signal response time delay, range: 10ms to 10s.
	Function	DI 1: Default for device self-test DI 2: Default for reset self-test faults and relay status

3.5.- Line disconnection detection function

This device features line disconnection detection. The KE and E terminals for monitor grounding status; if a disconnection or improper connection occurs, the fault LED on the panel lights up immediately. The LED turns off automatically once the connection is restored.

Signal lines (L1/+, L2/-) are monitored via a self-test mechanism, which must be triggered by pressing the [TEST] button. The fault LED lights up when a disconnection is detected during the self-test. After reconnection, a subsequent self-test is required to confirm normal status before the LED turns off. Details see **chapter 4.3**.

4.- INSTALLATION AND START-UP



The manual you hold in your hand contains information and warnings that the user should respect in order to guarantee a proper operation of all the instrument functions and keep it in safety conditions. The instrument must not be powered on and used until its definitive assembly is on the cabinet's door.

If the instrument is not used as manufacturer's specifications, the protection of the instrument will be damaged.

When any protection failure is suspected to exist (for example, it presents external visible damages), the instrument must be immediately powered off. In this case contact a qualified service representative.

4.1.- Installation method

BIM-M1000 is to be mounted on 35mm Din-rail.

- Step-1** Fasten a section of 35 mm DIN rail (at least 8 inches long) to the mounting surface with appropriate hardware.
- Step-2** Use the white plastic clips on the back of the BIM-M1000 to clip onto the rail.
- Step-3** Verify that the device is securely fastened to the wall.

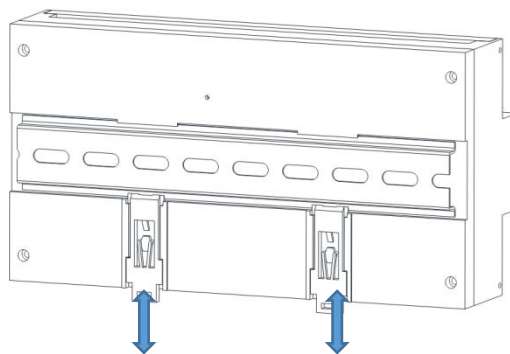

There have two flaps covers, can sealed by lead wire to protect unauthorized access terminal block, to achieve physical anti-theft function. Also capable of completely shielding the terminal head to prevent accident electrical shock.

Warning that with the instrument powered on, the terminals could be dangerous to touch and cover opening actions or elements removal may allow accessing dangerous parts.

Therefore, the instrument must not be used or operation key button until this is completely installed and close the cover.

4.2.- Dimension (Unit: mm)

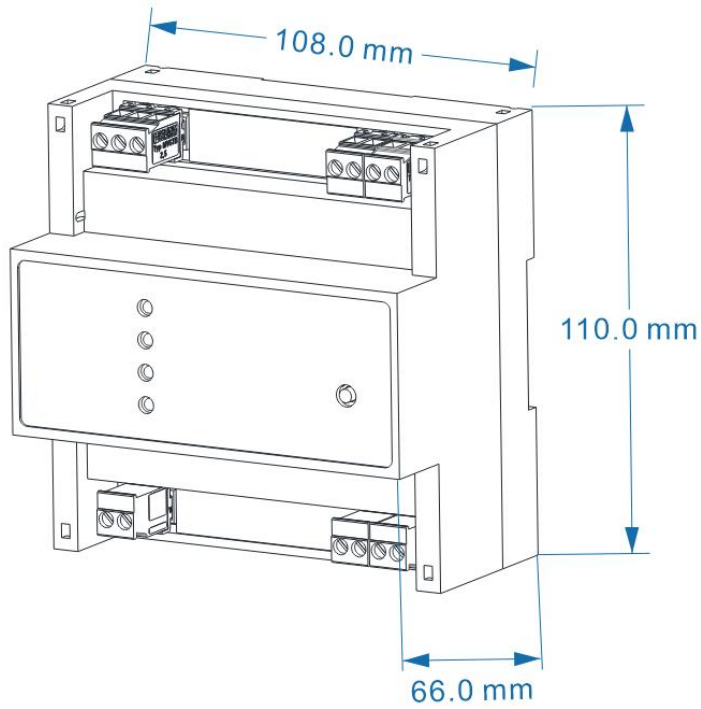

4.3.- Indicator lights and button function description



Indicator	Definition
PWR	Off: product is not powered on Green: Device is powered on and operating normally
ALM-1	Off: No alarm Yellow: Associated relay-1 triggered an alarm
ALM-2	Off: No alarm Red: Associated relay-2 triggered an alarm
Fault	KE/E line incorrect connection/ open-circuit fault Signal line (L1/+, L2/-) open-circuit fault

Button	Definition
TEST	Start signal line (L1/+, L2/-) open-circuit check
RST	Short press to reset fault and alarm status; hold for 2 seconds, and the power indicator light will flash.

Note:

- E, KE terminal faults trigger the fault LED alarm automatically and auto reset upon reconnection.
- L1/+, L2/- terminal not automatic alarm, need press [Test] to self-test, if disconnected, fault LED light on; after reconnection, press again [Test], fault LED light off.
- Press and hold the Test and Reset buttons simultaneously for 3 seconds to reset the communication parameters to default settings: address 1, baud rate 9600, parity n.8.1.

4.4.- Terminal Definition

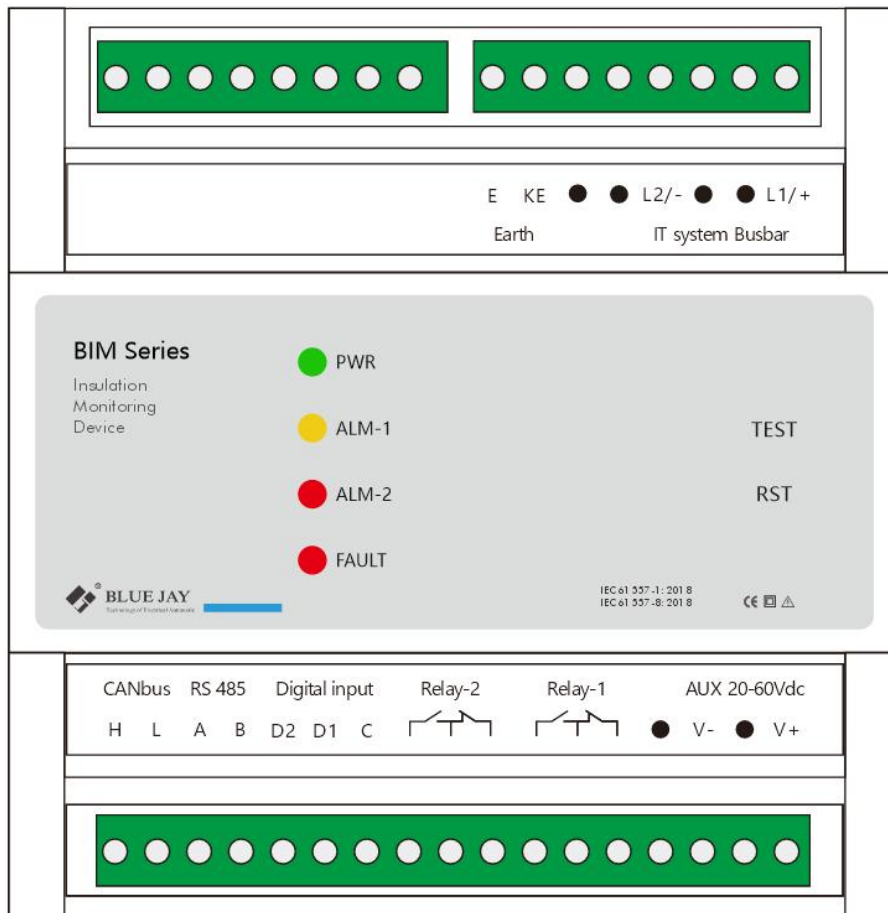

Marked	Notes
E, KE	Protective earth
L1/+	Connect to AC system L1/ DC system positive pole
L2/-	Connect to AC system L2/ DC system negative pole
CANBUS H/ L (optional)	CANBUS high port
	CANBUS low port
RS485 A, B	RS485 communication interface A, B
Digital input C, D1, D2	C: Common terminal D1: Digital input-1 D2: Digital input-2
Relay-1/ 2	Digital output-1 Digital output-2
V+, V-	AUX power supply 20-60Vdc

4.5.- Typical wiring diagram

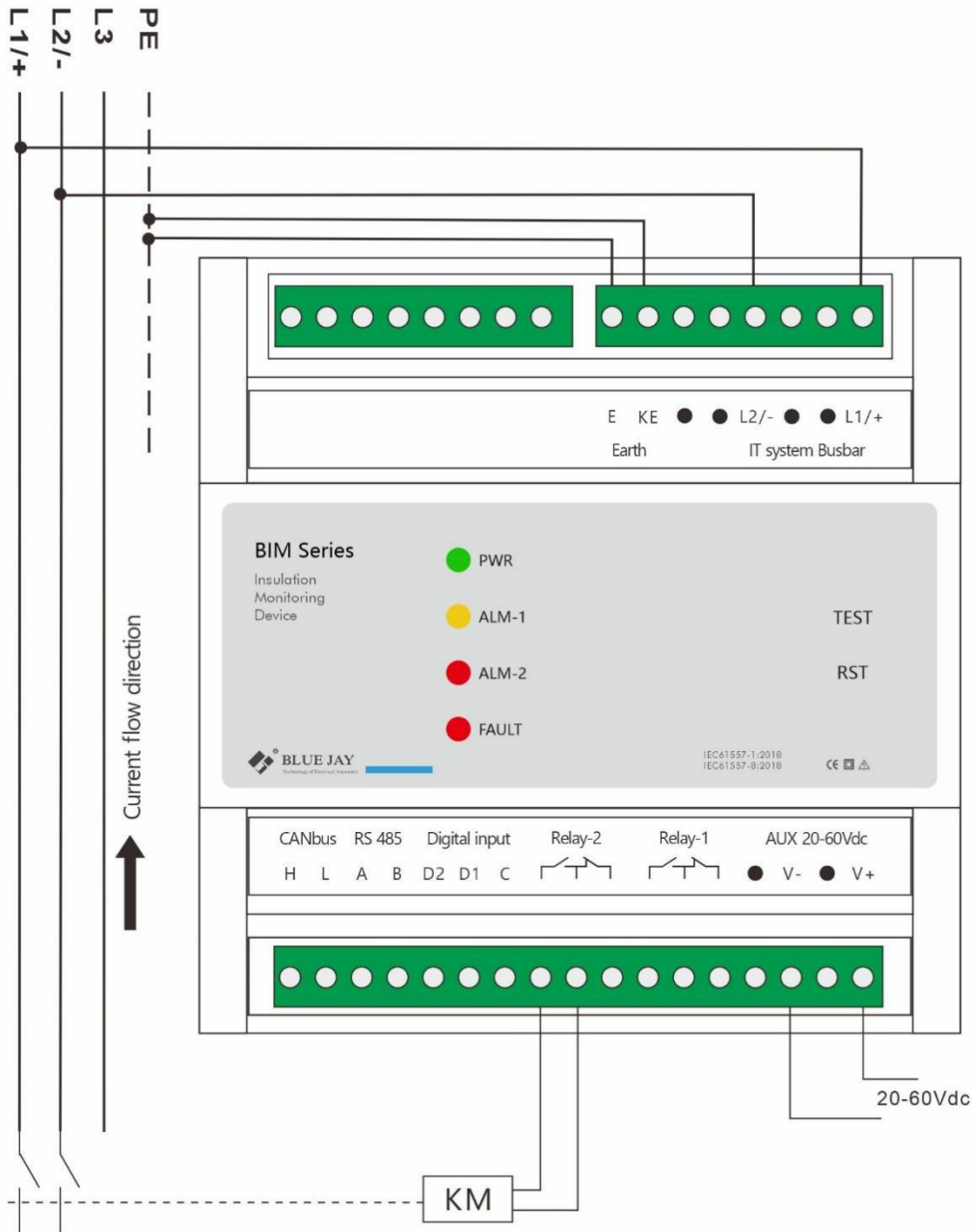

In DC system: Connect terminal +, - to positive (+) and negative (-) terminals of DC busbar.

Measurement parameters:

- Positive pole to earth insulation resistance (IR+)
- Negative pole to earth insulation resistance (IR-)
- Positive and negative pole to earth parallel insulation resistance (IRz)
- DC system bus voltage

In AC system (Support single and three phase)

Single-phase: Connect L1 and L2 terminals to the corresponding L1 and L2 of the system.

Three-phase: Connect L1 and L2 terminals to any two of the three phases (L1, L2, or L3).

Measurement parameters:

- L1 and L2 to earth parallel insulation resistance (IRz)
- Measure the L1 to L2 line voltage (L-L)

Note:

Users must first configure measure AC system or DC system in register map (0x006F).

5.- COMMUNICATION INTERFACE

BIM-M1000 supports two industry-standard communication protocols:

RS485 Modbus RTU: Used for data exchange and parameter configuration with a host computer.

Optional CANbus custom protocol: Allows networking with other devices supporting the CAN protocol.

Note:

- If CANbus is selected, CANbus and RS485 cannot be used simultaneously.
- In present product version, CANbus related parameters need to be completed via RS485. Parameters cannot be set directly through the CAN interface. Details see register 0x012C-0x0131 of [chapter 5.4.2](#).

5.1.- CANbus communication connection

The CAN communication circuit of BIM-M1000 insulation monitor defaulted connected with a terminal resistance of 120Ω. Terminals H and L correspond to CANbus high port and low port respectively.

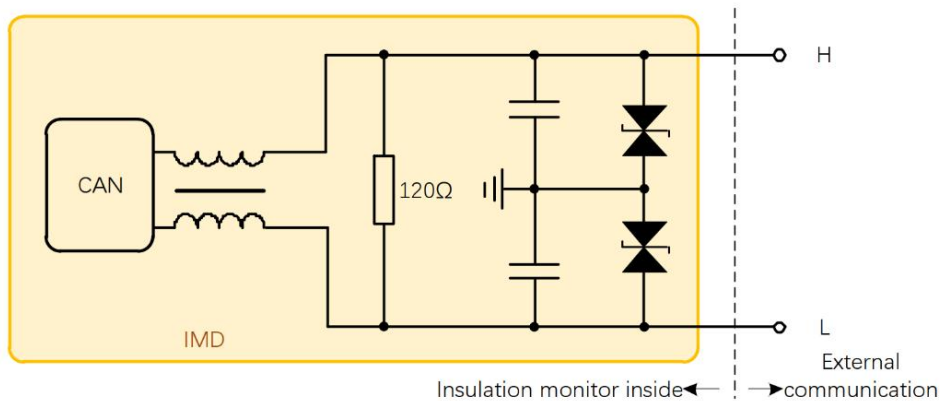

5.2.- RS485 communication connection

Users can send and receive data frames through the RS485 communication port. The circuit is equipped with 510Ω terminal resistance. For details, see communication protocol. Terminals A and B correspond to RS485 outputs A and B respectively.

5.3.- RS485 communication protocol

BIM-M1000 device supports Modbus RTU protocol, using Modbus RTU 0x03/0x06 command; Default baud rate 9600, communication address 001, no parity, stop bit 1, data bit 8. The time interval between each byte in the sent frame shall not exceed 20ms, otherwise the frame will be cleared.

Modbus RTU Frame Format:

Address code	1 BYTE	Slave device address 1-247
Function code	1 BYTE	Indicates the function codes like read coils / inputs
Data code	4 BYTE	Starting address, high byte Starting address, low byte Length of registers, high byte Length of registers, low byte
Error Check code	2 BYTE	Cyclical redundancy check (CRC)

MODBUS FUNCTIONS:

Code	Meaning	Description
FUNCTION 03	Read hold register	This function permits to read all the electrical parameters
FUNCTION 06	Write single register	This function permits to write a value into a single holding register.

5.4.- Register map

5.4.1.- Parameter query, read only, function 03 to read.

Register	Data	Byte mode		Description
0x0000-0x000A	Reserved			
0x000B	DC bus voltage	Int	1	Unit 0.1V,16-bits
0x000C	Insulation resistance	Int	1	Unit: kΩ, integer value (0xFFFF: invalid value; 0xEA60: resistance value greater than 30 MΩ)
0x000D	Minimum insulation resistance	Int	1	The minimum measured insulation resistance
0x000E-0x0014	Reserved			
0x0015	L1 to L2 voltage	Int	1	Unit 0.1V,16-bits
0x0016-0x0028	Reserved			
0x0029	Positive pole to earth insulation resistance IR+	Int	1	Unit: kΩ, (0xFFFF: invalid value; 0xEA60: resistance > 30 MΩ)
0x002A	Negative pole to earth insulation resistance IR-	Int	1	
0x002B	DC alarm status	Int	1	DC fault percentage (only valid when DC voltage ≥ 20V) Offset: 1: 0...25% DC positive pole fault 2: 25...75% Symmetrical fault 3: 75...100% DC negative pole fault
0x002C	DC to ground offset voltage	Int	1	DC to ground offset voltage absolute value, units: 0.1V ((only valid when DC voltage ≥ 20V).
0x002D-0x0032	Reserved			
0x0033-0x0035	Reserved			
0x0036	DC component (positive pole impedance %)	Int	1	Unit: 0.1% 0% = DC positive terminal fault 100% = DC negative terminal fault

0x0037-0x0064	Reserved
---------------	----------

5.4.2.- Parameters query and settings, read and write, fun03 to read/ 06 to write

Register	Data	Byte mode		Description
0x0065-0x006D	Reserved			
0x006E	Present working mode	Int	1	0: Automatic insulation monitoring after powered on 1: Manual trigger insulation monitoring after powered on
0x006F	Present measurement mode	Int	1	0: DC system 1: AC system
0x0070	Insulation monitoring function	Int	1	0: Turn off insulation monitoring function 1: Turn on insulation monitoring function
0x0071	Reset function	Int	1	0: Manual reset 1: Auto reset
0x0072-0x00F9	Reserved			
0x00FA	RS485 address	Int	1	Default: 1; range:1-247
0x00FB	Baud rate	Int	1	Default: 9600; 0: 1200; 1: 2400; 2: 4800; 3: 9600; 4: 19200
0x00FC	Data format	Int	1	Default: n.8.1; 0: n.8.1; 1: o.8.1; 2: e.8.1; 3: n.8.2
0x00FD-0x012B	Reserved			
0x012C	CAN send ID high 16 bits	Int	1	Default: 0X1819
0x012D	CAN send ID low 16 bits	Int	1	Default: 0XA1A5
0x012E	CAN receive ID high 16 bits	Int	1	Default: 0X1819
0x012F	CAN receive ID low 16 bits	Int	1	Default: 0XA1A4
0x0130	CAN baud rate	Int	1	Default: 250Kbps; range: 0-1000kbps

0x0131	CAN send cycle	Int	1	Range: 1-10000ms
0x0132-0 x0136	Reserved			

5.4.3.- Alarm, DI, DO status, readable& writable, function 03 to read/ 06 to write

Register	Data	Description
0x0137	Alarm-1 Mode	0: Off; 1: Rising; 2: Falling
0x0138	Alarm-1 Data	Choose 1 from 8 functions, repeatable: 0: Insulation resistance pre-alarm 1: Insulation resistance alarm 2: Voltage over threshold 3: System leakage capacitance over threshold 4: DC offset over threshold 5: Reserved function 6: Reserved function 7: Reserved function
0x0139	Alarm-1 Delay	Range: 0000-9999, default 1000ms
0x013A	Alarm-1 Trip value	Range: 0000-9999 For IR pre-alarm: unit: Ω/V For IR alarm: unit: Ω/V For Volt: unit: 0.1V For YCap: unit: 0.1 μ F For DCoff: unit: 0.1V
0x013B	Alarm-1 Hysteresis.	0-9999: hysteresis value
0x013C-0 x014A	Reserved	
0x014B-0 x014F	Alarm-2	The same as Alarm-1
0x0150-0 x015E	Reserved	
0x015F-0 x0163	Alarm-3	The same as Alarm-1
0x0164-0 x0172	Reserved	
0x0173-0 x0177	Alarm-4	The same as Alarm-1
0x0178-0 x0186	Reserved	

0x0187-0 x018B	Alarm-5	The same as Alarm-1
0x018C-0 x019A	Reserved	
0x019B-0 x019F	Alarm-6	The same as Alarm-1
0x01A0-0 x01AE	Reserved	
0x01AF-0 x01B3	Alarm-7	The same as Alarm-1
0x01B4-0 x01C2	Reserved	
0x01C3-0 x01C7	Alarm-8	The same as Alarm-1
0x01C8-0 x02BC	Reserved	

Register	Data	Description
0X02BD	DO-1 mapping data	0: OFF 1: Alarm-1 2: Alarm-2 3: Alarm-3 4: Alarm-4 5: Alarm-5 6: Alarm-6 7: Alarm-7 8: Alarm-8
0X02BE	DO-1 link data	0: OFF 1: Alarm-1 2: Alarm-2 3: Alarm-3 4: Alarm-4 5: Alarm-5 6: Alarm-6 7: Alarm-7 8: Alarm-8
0X02BF	DO-1 association logic mode	0: AND; 1: OR
0X02C0	DO-1 default status	0: NC (when power on, relay closes and when reached the trigger condition relay opens). 1: NO (default) 2: Flash: relay is flashing, flashing frequency: 1 second ON / 1 second OFF

0X02C1-0X02D0	Reserved	
0X02D1-0X02D4	DO-2 setting	The same as DO-1
0X02D5-0X03E8	Reserved	

Register	Data	Description
0X03E9	DI-1 Mode	0: OFF 1: Active high 2: Active low
0X03EA	DI-1 Delay	Range 10ms-10s
0X03EB	DI-1 Function	Choose 1 from 2 functions, repeatable: 0: Test 1: Reset
0X03ED-0X03FC	Reserved	
0X03FD-0X03FF	DI-2	The same as DI-1
0X0400-0X0514	Reserved	

5.4.4.- Query alarm status and self-test fault status, read only, function 03 to read

Register	Data	Byte mode		Description
0X0516-0 X0546	Reserved			
0X0547	Alarm status	Int	2	Bit 0: Alarm 1 status (0: Normal; 1: Triggered) Bit 1: Alarm 2 status (0: Normal; 1: Triggered) Bit 2: Alarm 3 status (0: Normal; 1: Triggered) Bit 3: Alarm 4 status (0: Normal; 1: Triggered) Bit 4: Alarm 5 status (0: Normal; 1: Triggered) Bit 5: Alarm 6 status (0: Normal; 1: Triggered) Bit 6: Alarm 7 status (0: Normal; 1: Triggered) Bit 7: Alarm 8 status (0: Normal; 1: Triggered) Bit 8-15: Reserved
0X0548	DI status	Int	2	Bit0: DI1 status (0: Normal; 1: Triggered) Bit1: DI2 status (0: Normal; 1: Triggered)
0X0549	DO status	Int	2	Bit0: DO1 status (0: Normal; 1: Triggered) Bit1: DO2 status (0: Normal; 1: Triggered)
0X054A	KE, E line fault status	Int	2	Bit 0: (0: no open circuit; 1: open circuit)
0X054B	L1/+, L2/-Signal line fault status	Int	2	Bit 0: (0: no open circuit; 1: open circuit)
0X054C- 0X0578	Reserved			

Note: Bit sequence is from LSB to MSB.

5.4.5.- Factory information query, read only, function 03 to read (None available)

Register	Data	Description
0XFFDC	Manufacturer	Manufacturer name or device code
0XFFDD	Device model	Device model information
0XFFDE	Product number	Unique product number for internal management or certification
0XFFDF	Firmware version	Present running firmware version number
0XFFE0	Firmware date	Firmware compilation or release timestamp information
0XFFE1	Hardware version	Device hardware version number
0XFFE2	Production week	Indicates the year and week of manufacture, e.g., year 25, week 25
0XFFE3	SN code	Unique factory serial number of the device, used for tracking and identification.
0XFFE4	MAC address (Reserved)	
0XFFE5-0XFFFF	Reserved	

6.- SAFETY CONSIDERATIONS



All installation specifications described in the previous chapters named: **INSTALLATION AND STARTUP, INSTALLATION MODES and SPECIFICATIONS.**

Please note that with the instrument powered on, the terminals could be dangerous to touch and cover opening actions or elements removal may allow accessing dangerous parts. This instrument is factory-shipped at proper operation conditions.

- ◆ The device must have professional installation and maintenance.
- ◆ Any operation of the device, you must cut off the signal and power.

7.- MAINTENANCE

The BIM-M1000 does not require any special maintenance. No adjustment, maintenance or repairing action should be done when the instrument is open and powered on, should those actions are essential, high-qualified operators must perform them.

Before any adjustment, replacement, maintenance or repair operation is carried out, the instrument must be disconnected from any power supply source.

When any protection failure is suspected to exist, the instrument must be immediately put out of service. The instrument's design allows a quick replacement in case of any failure.

For any inquiry about the instrument performance or any failure, contact to Blue Jay's technical service.

Blue Jay - After-sales service

E-mail: tech@cqbluejay.com